

STEREO Impact Boom FM2 Thermal Cycling Report

Document # IMP-591-DOC

Revision: -

Written By: Jeremy McCauley

Approved By: Dave Curtis

Date: September 29, 2004

1. OVERVIEW

The STEREO Boom thermal cycling tests for the Flight Model 2 Boom were conducted August 27 through September 14, 2004 at the Space Sciences Laboratory in Berkeley, California using the STEREO IMPACT Boom Thermal Vacuum Chamber. Robert Ullrich, Lancelot Braasch, Dave Curtis and Jeremy McCauley were in attendance for instrument handling, verification and test observation.

Thermal cycling was conducted on the Boom (See Figure 1) between survival temperatures of -33°C and 40°C with a minimum one (1) hour soak at each extreme. There were 7 cycles total during this test (6 $\frac{1}{2}$ continuous cycles followed by 1 half cycle). Contamination measurements were taken during the seventh "hot" (40°C) soak. Deployment was performed after the seventh "hot" (40°C) soak. The chamber was then vented for inspection of the boom and restowing. The stowed Boom was returned to the tank for a cold thermal cycle, after which deployment was performed following the "cold" (-33°C) soak.

All thermal cycling and deployments were completed and no further testing is required. Post-test inspection during stowing operations showed no degradation to the Boom mechanically, structurally, or functionally.

2. REFERENCE DOCUMENTS (Attached):

APL Document APL 7381-9003 Rev A – STEREO Environment Definition, Observatory and Instrument Test Requirements Document (Not attached)

UCB Document IMP-563-DOC – Thermal Vacuum Cycling Test Procedure

PR1020 FM2 Actuator Harness

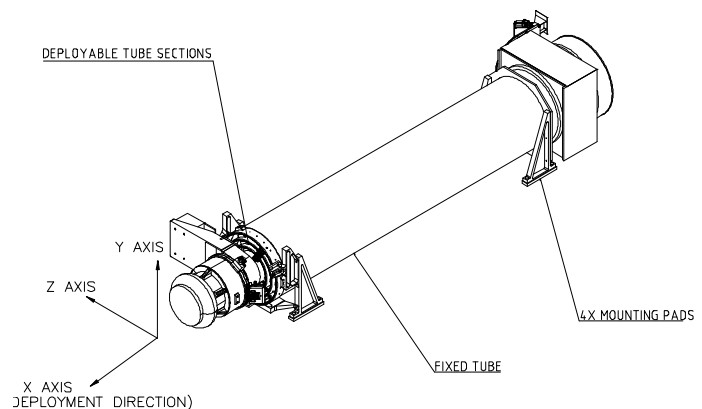
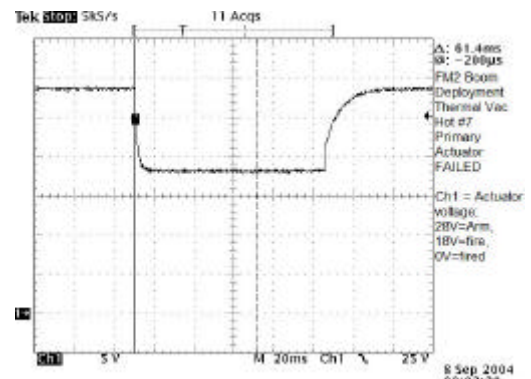

Figure 1: Definition of Axes

3. PASS/FAIL CRITERIA

The Boom was successfully deployed after completion of the seventh hot soak. Deployment failed on the primary actuator circuit due to incorrect wiring (firing circuit response shown at right), but was successful on the secondary circuit (See PR1020, Attached). Deployment was watched via video taken inside the chamber. Manual inspection after cooling and venting verified all pins had locked and the Boom was fully deployed. Resonance testing verified the Boom stiffness was within expected values.

The Boom was successfully deployed on the corrected primary actuation circuit after completion of the seventh cold soak. Deployment was watched via video camera from inside the chamber. Manual inspection after warming and venting verified that all pins had locked and the Boom was fully deployed. Resonance testing verified the Boom stiffness was within expected values.



4. TQCM MEASUREMENTS

A TQCM at -20°C was monitored within the chamber at all times during thermal vacuum cycling. During the seventh hot soak, data was taken for eight (8) consecutive hours at 300 second intervals in order to qualify the Boom in regards to outgassing rates. The following is a plot of the TQCM activity during that period. A final rate of approximately 50 hertz per hour was reached.

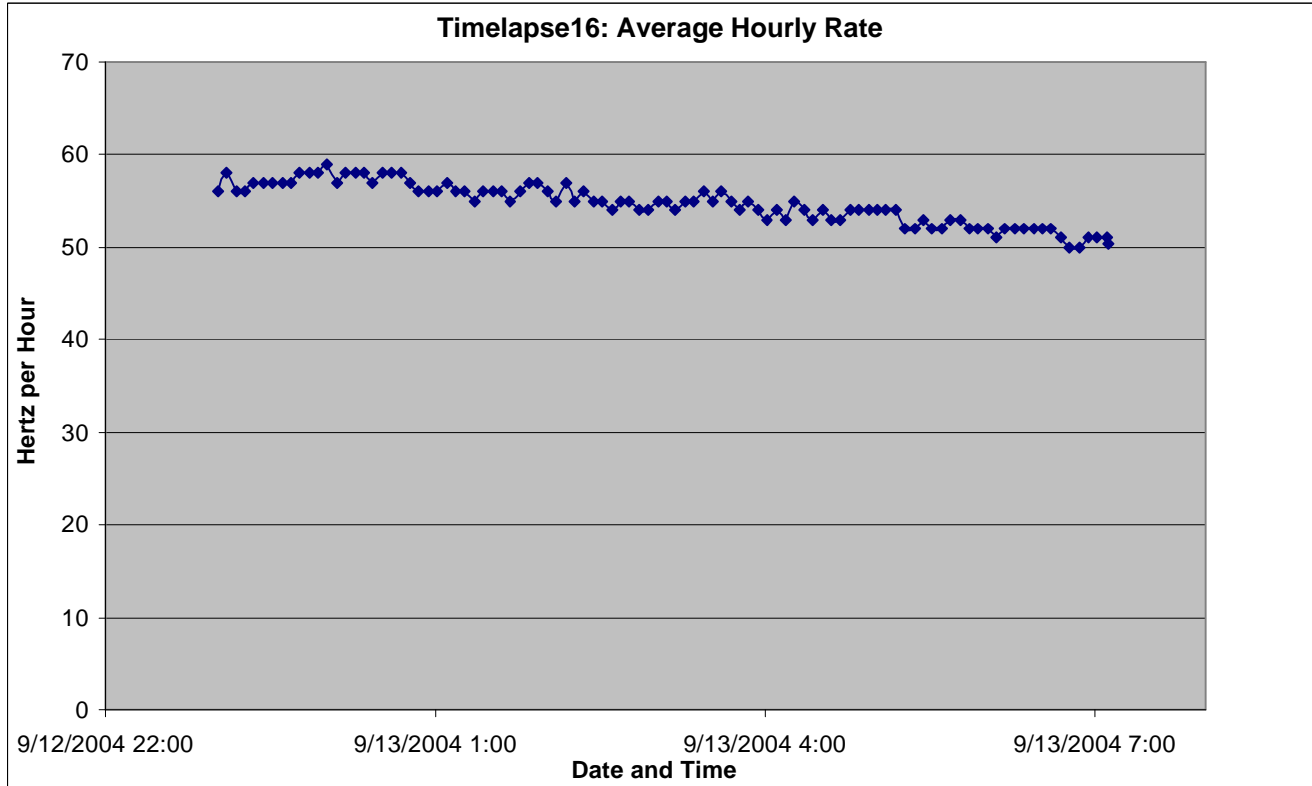

5. ACTUATOR MONITORING

The Shape Memory Allow Release (SMAR) device was monitored at deployment to verify the pulse power and time required to actuate. The resultant plots are shown below. 28V is armed, ~17V is firing, 0V is fired. Actuation time is 30ms hot and 60ms cold.

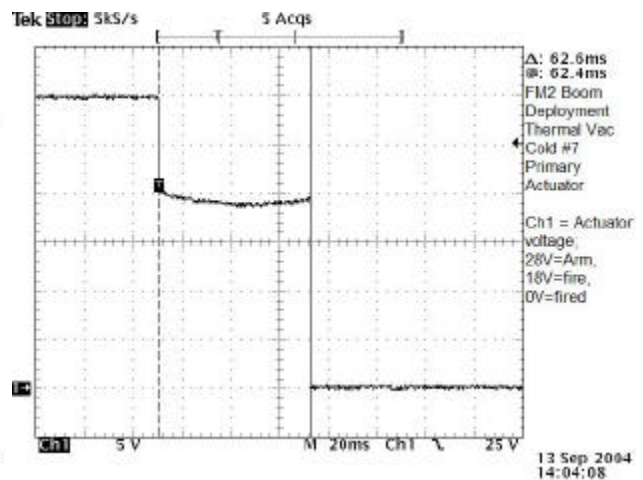
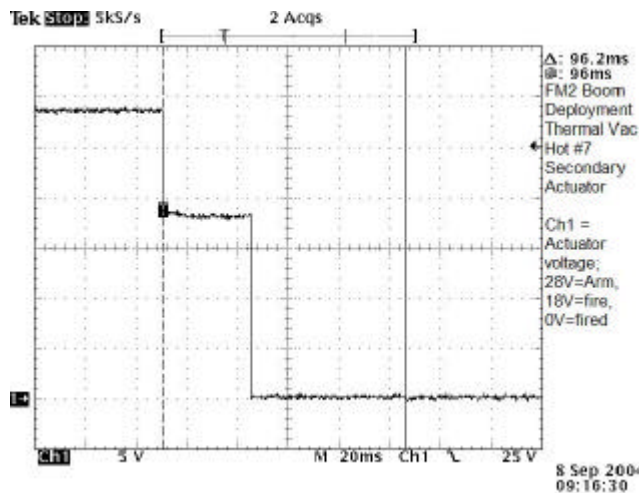

6. RESONANCE TESTING

Resonance testing was done to verify that the Boom was fully deployed with all pins locked and to verify that the Boom structural response was similar regardless of deployment temperature. Resonance was measured using an Endevco 61-A500 Isotron Accelerometer through a Model 133 signal conditioner into DAQView. The resultant plots are shown below as is a plot from a room temperature test prior to vibration and thermal vacuum testing. For the post-vibration test, averaging 5 cycles gives 2.06Hz with all mass dummies included. For the hot case deployment, averaging 5 cycles gives 2.00Hz with all mass dummies included. For the cold case deployment, averaging 5 cycles gives 2.01Hz with all mass dummies included. The consistency of these numbers is within the accuracy of the calculations. Thus, the devices show that deployment resonance frequencies are unaffected by temperature extremes.

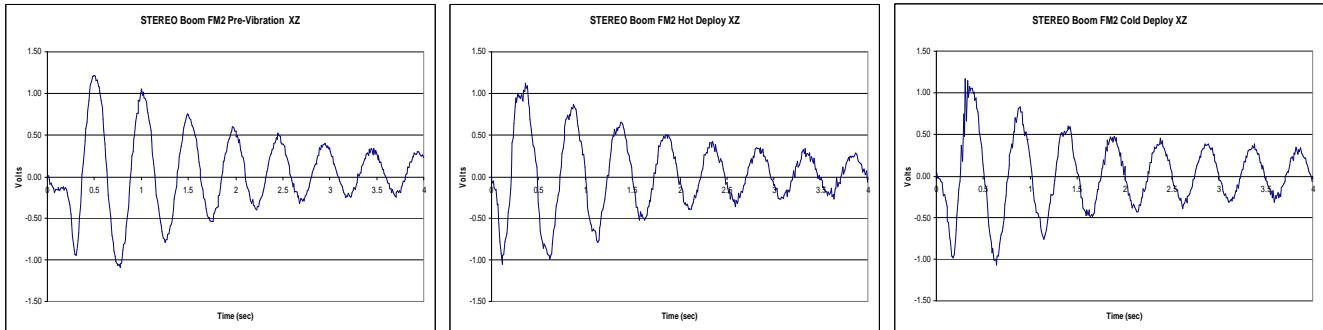

7. Magnetometer (Mag) CPT

The Flight Model 2 Mag was attached to the Boom for all vibration and thermal vacuum testing. Comprehensive Performance Tests (CPTs) were performed during each hot or cold soak using the magnetometer section of the IDPU CPT procedure. The FM2 IDPU (with ETU LVPS) supported the test from outside the chamber. All CPTs passed. The attached trending data was analyzed by the magnetometer test and no anomalous trend was found.

MAG FM2 Performance Trend			MAG Temp			IDPU Temp			Heater On HRP			RMSx			RMSy			RMSz			IFC X			IFC Y			IFC Z		
Date	File	Test	MAG Temp	IDPU Temp	Heater On HRP	RMSx	RMSy	RMSz	IFC Rev	Sample Time	Amplitude	Rate	Sample Time	Amplitude	Rate	Sample Time	Amplitude	Rate	Sample Time	Amplitude	Rate	Sample Time	Amplitude	Rate	Sample Time	Amplitude	Rate		
Aug 26 2004	0408261604.tlm	Pre-boom-vibration	22.8	30.1	7.1	8.6	1.0	9.5	8/5/2004	-23.2	8901	9.4	-22.2	8901	9.4	-20.9	8903	8.6											
Aug 27 2004	0408271918.tlm	Post-boom-vibration	25.7	30.1	7.1	2.6	2.5	7.8	8/5/2004	-22.6	8895	9.3	-22.0	8898	9.3	-22.0	8898	9.1											
Aug 31 2004	0408310828.tlm	Boom Tvac Hot #2	38.8	36	7	2.7	1.0	1.8	8/5/2004	-20.8	8777	9.1	-21.6	8982	9.9	-23.3	9354	10.2											
Aug 31 2004	0408310828.tlm	Boom Tvac Cold #2	-28.2	37	44.8	1.5	0.9	1.3	8/5/2004	-22.3	8796	9.6	-21.5	8967	9.6	-22.3	9346	9.4											
Sep 1 2004	0409010000.tlm	Boom Tvac Hot #3	38.9	36	7.1	4.5	2.7	6.2	8/5/2004	-21.3	8777	9.2	-21.0	8984	9.5	-22.0	9350	9.4											
Sep 1 2004	0409010000.tlm	Boom Tvac Cold #3	-26.5	38	45.1	1.8	3.5	1.7	8/5/2004	-23.0	8798	9.8	-21.6	8971	9.5	-22.1	9347	9.3											
Sep 2 2004	0409020000.tlm	Boom Tvac Hot #4	38.9	36	7	2.8	1.2	1.5	8/5/2004	-21.5	8781	9.3	-21.7	8983	9.8	-22.0	9348	9.4											
Sep 2 2004	0409020000.tlm	Boom Tvac Cold #4	-27.6	39.1	45	2.0	1.1	1.0	8/5/2004	-21.5	8781	9.3	-21.7	8983	9.8	-22.0	9347	9.4											
Sep 3 2004	0409030000.tlm	Boom Tvac Hot #5	39	36.7	7.1	1.4	1.3	1.1	8/5/2004	-22.1	8779	9.6	-20.5	8982	9.2	-21.7	9351	9.3											
Sep 3 2004	0409030000.tlm	Boom Tvac Cold #5	-25.6	39	45.1	1.7	1.4	1.2	8/5/2004	-21.8	8799	9.2	-21.7	8970	9.5	-22.1	9346	9.3											
Sep 7 2004	0409070000.tlm	Boom Tvac Hot #6	39.8	42.4	7.1	1.6	1.4	1.0	8/5/2004	-20.7	8776	8.9	-19.4	8982	8.6	-21.9	9351	9.4											
Sep 7 2004	0409070000.tlm	Boom Tvac Cold #6	-27.3	44.9	45.2	1.4	1.1	1.1	8/5/2004	-22.0	8802	9.2	-21.5	8973	9.4	-23.3	9348	9.8											
Sep 8 2004	0409080000.tlm	Boom Tvac Hot #7	39.3	41	7.1	1.8	1.0	1.0	8/5/2004	-20.8	8778	9.0	-20.6	8981	9.3	-22.0	9349	9.4											
Sep 8 2004	0409080000.tlm	Post deploy (Tvac)	38.9	43	7.1	1.7	0.7	1.0	8/5/2004	-21.0	8808	9.0	-20.8	8984	9.4	-21.7	9388	9.2											
Sep 13 2004	0409130000.tlm	Restowed, Hot (Tvac)	39.2	33.7	7.1	1.5	0.8	1.4	8/5/2004	-21.8	8776	9.5	-21.0	8979	9.6	-21.7	9347	9.4											
Sep 13 2004	0409130000.tlm	Boom Tvac Cold #7	-27.3	36.3	44.9	2.1	0.6	1.2	8/5/2004	-22.1	8798	9.3	-21.5	8969	9.5	-22.8	9344	9.6											
Sep 13 2004	0409130000.tlm	Post deploy (Tvac)	-25.7		43.7	1.8	1.1	0.5	8/5/2004	-22.0	8819	9.3	-21.3	8971	9.4	-22.0	9376	9.2											

8. Magnetometer Deployment Data

Data was recorded from the Magnetometer during Boom Deployment. The data is shown below. Features to note are the sharp change in slope at the point deployment commenced and the two evident discontinuities from sections of the Boom locking up. A magnified view of the end of this sequence, shown below, shows the ringing induced from within the Boom as it reaches its end of travel and “rings” as a solid structure. The frequency of this ringing is closely related to the frequency found in the resonance stiffness measurements of the Boom.

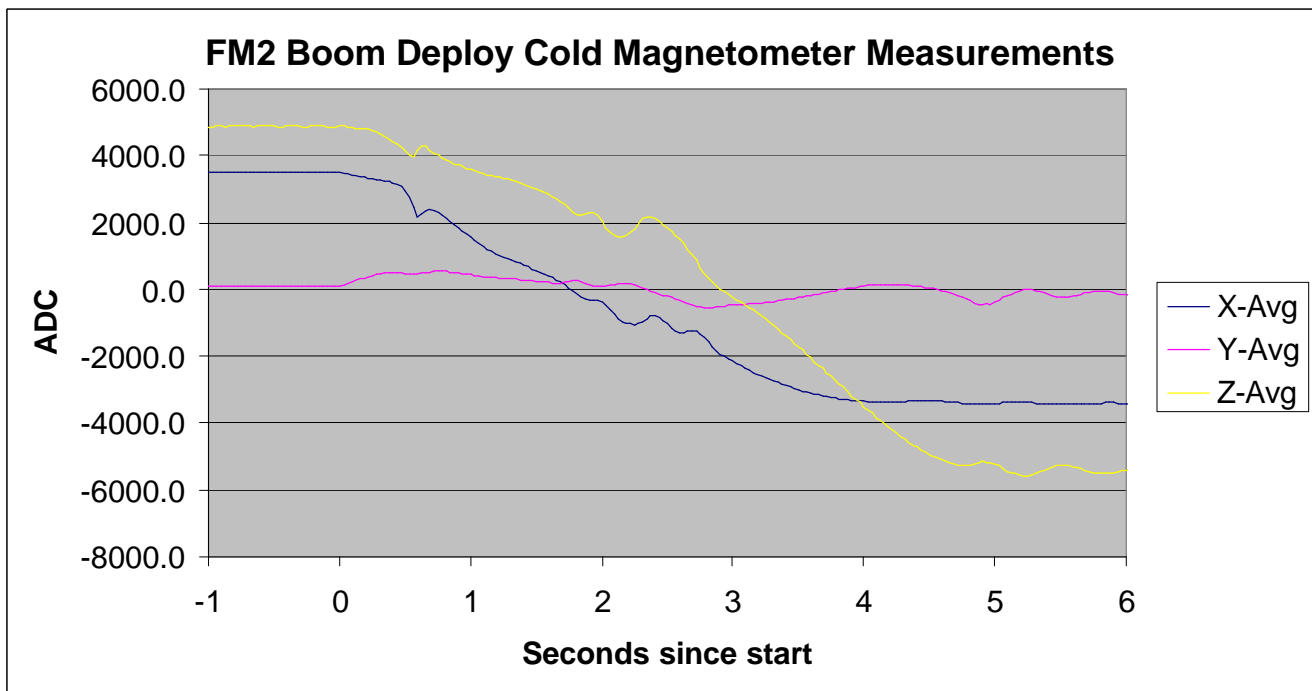
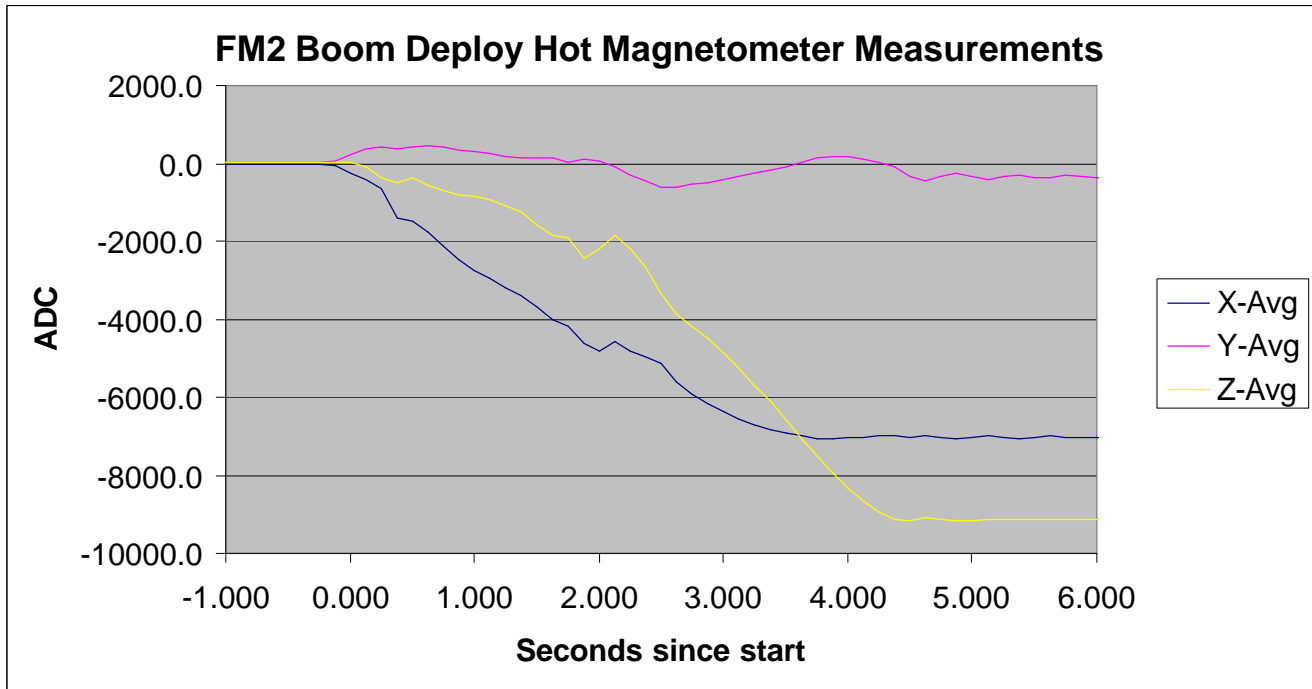

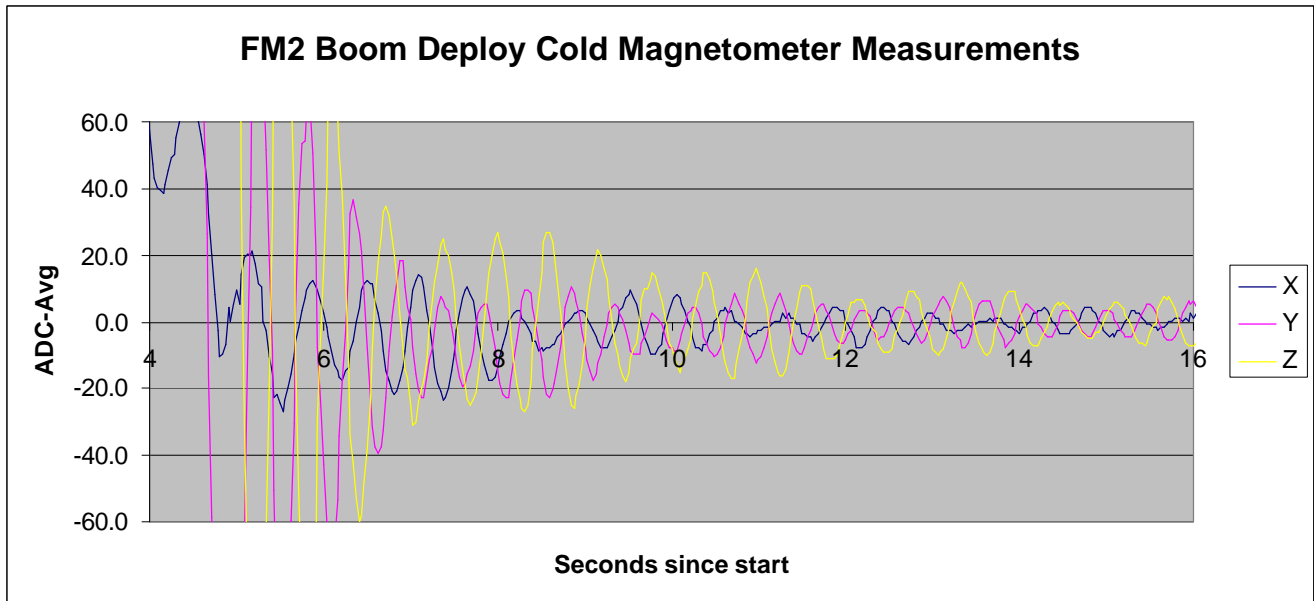
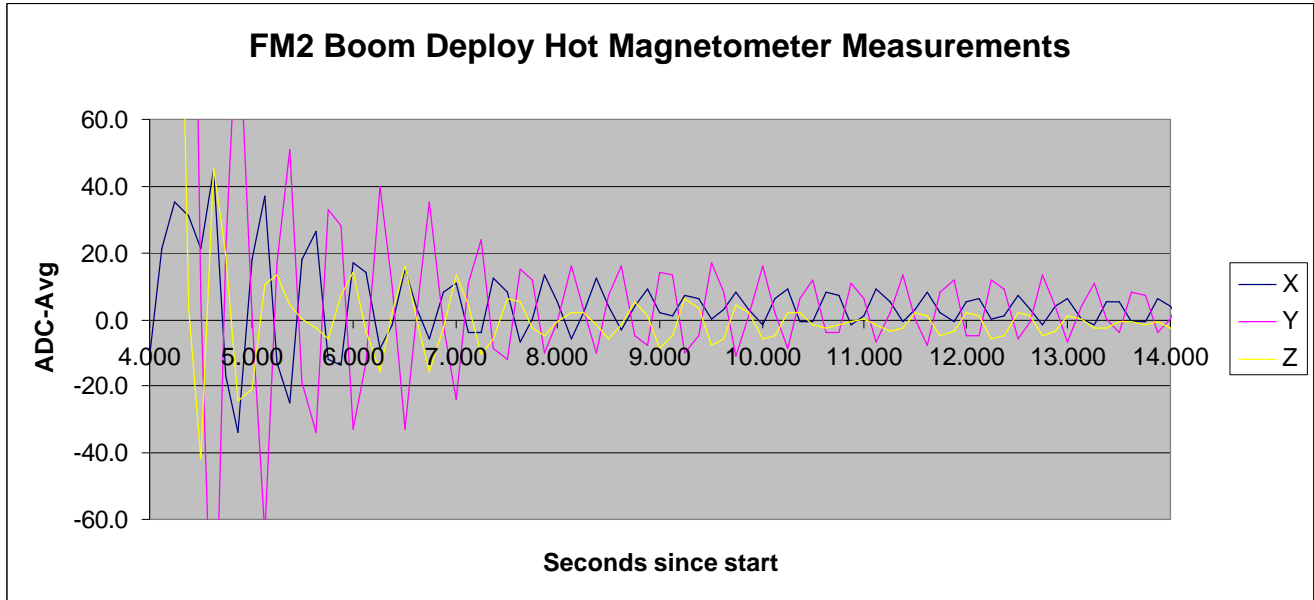

9. THERMOCOUPLE PLACEMENT

Thermocouple:	Placement:	TC8	Bobbin Top
TC1	Upper Shroud (Control)	TC9	Flyweight Brake Cover
TC2	Lower Shroud (Control)	TC10	Upper Mounting Foot
TC3	Baseplate (Control)	TC11	Connector Housing
TC4	Cold Plate (Control)	TC12	Lower Shroud Opposite Bobbin
TC5	218 Ring Top	TC13	Lower Shroud (Spurious)
TC6	Baseplate Front	TC14	Upper Shroud
TC7	Lower Mounting Foot	TC15	Upper Shroud

10. THERMAL TEST PROFILE

Durations modified as required.

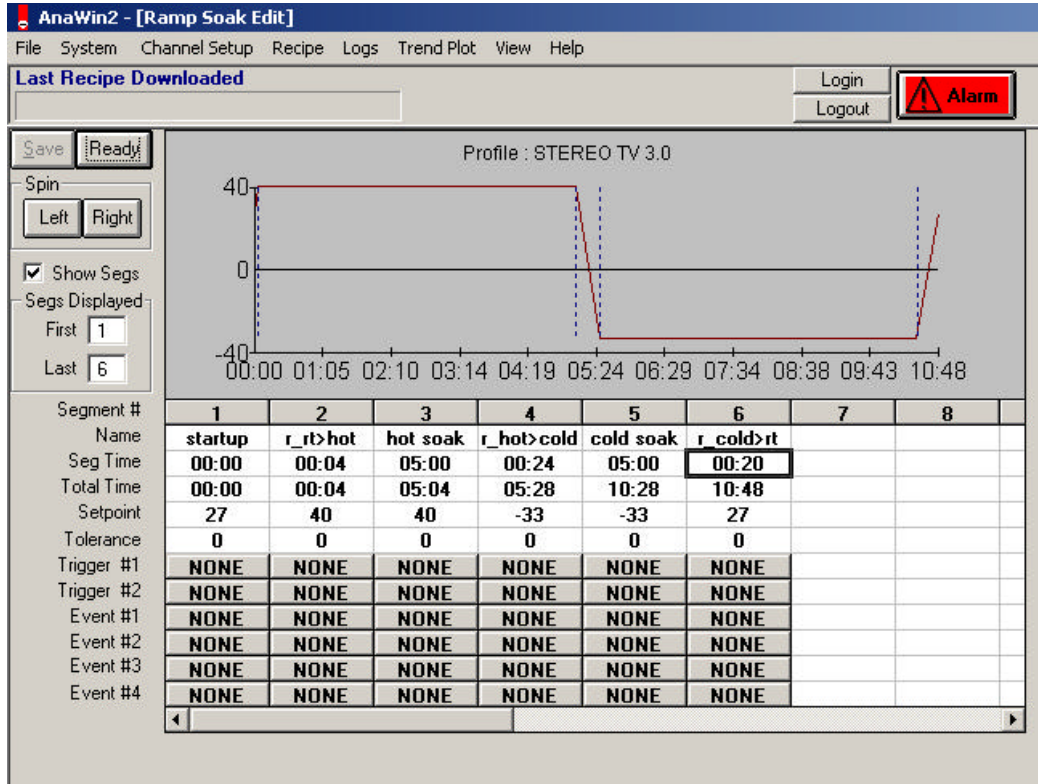

11. THERMOCOUPLE PROFILES

Attached in file: IMP-591-DOC APPENDIX STEREO FM2 Boom TV Temp Plots.pdf.

Note that the Magnetometer did not have its thermal blanket on (to facilitate faster cycling), and other than for short intervals during the CPTs and during the transition from cold to hot in cycle 2, the MAG heater was not powered on (the heater is not sized to maintain the MAG temperature in the absence of the blanket). The MAG heater lower (full on) set point is ~-18C, while the MAG typically reached ~-27C during cycling, providing plenty of margin to the predicted on-orbit heater-controlled temperature, while staying within the safe temperature range (to -33C). The fact that the MAG sensor was warmer than the rest of the boom is due to the fact that it is thermally isolated from the boom, and had some view factor to the room temperature chamber walls through the hole in the shroud that the boom deploys through.

12. PRESSURE PROFILE

