

STEREO *IMPACT*

IDPU Internal Interface Design

IDPUDesign_B.doc
Version B – 2002-Jun-03

David Curtis, UCB IMPACT Project Manager

Document Revision Record

Rev.	Date	Description of Change	Approved By
A	2002-Apr-16	Preliminary Draft	-
B	2002-Jun-3	<ul style="list-style-type: none"> • Modify internal connector locations (MAG, DCB, STE-U) • Add MAG heater board outline 	

Distribution List

Dave Curtis, UCB
 Steve McBride, UCB
 Heath Bersch, UCB
 Peter Berg, UCB
 Dorothy Gordon, Elf
 John Scheifele, GSFC

Table of Contents

Document Revision Record	i
Distribution List	i
1. Introduction	1
1.1. <i>Document Conventions</i>	<i>1</i>
1.2. <i>Applicable Documents</i>	<i>1</i>
2. Box Design	1
3. Board Outlines	1
4. Internal Connector	1
4.1. <i>Internal Connector Pinout</i>	<i>1</i>
4.2. <i>Signal Characteristics</i>	<i>1</i>

1. Introduction

This document describes the internal mechanical and electrical design of the STEREO IMPACT IDPU for use by the electronic designers in designing their circuit boards. External interfaces are described elsewhere.

1.1. Document Conventions

In this document, **TBD** (To Be Determined) means that no data currently exists. A value followed by **TBR** (To Be Resolved) means that this value is preliminary. In either case, the value is typically followed by a code such as UCB indicating who is responsible for providing the data, and a unique reference number.

1.2. Applicable Documents

The following documents include drawings and STEREO Project policies. All documents and drawings can be found on the Berkeley STEREO/IMPACT FTP site:

<http://sprg.ssl.berkeley.edu/impact/dwc/>

1. ICD/IDPUICD_B - IDPU ICD drawing
2. ICD/Block_E - IMPACT block diagram
3. ICD/ImpactHarnessSpec_D - IMPACT Harness specification (includes IDPU external connector pinouts)
4. ICD/IMPACTSerialInterface_E – serial instrument interface spec

2. Box Design

The IDPU circuit boards are mounted into trays as shown in Figure 1 and 2. The trays are (from bottom to top) the Power Converter, DCB, MAG, and STE-U trays. The top three trays hold one PWB per tray, while the bottom tray holds the Low Voltage Power Converter (on the left hand side) and the Mag Heater Converter (on the right hand side, in addition to harnessing).

3. Board Outlines

Dimensioned board outline drawings are shown in figures 3,4,5, and 6. Note that the pin locations for the internal connector in the board outlines are not representative; the actual pin rows are staggered.

The bottom tray contains both the LVPS and Mag Heater supply. These shall be hard-wired to the power connector, IDPU-J1, and the internal connector. The mounting of the internal connector in the bottom tray is **TBD-UCB-001**.

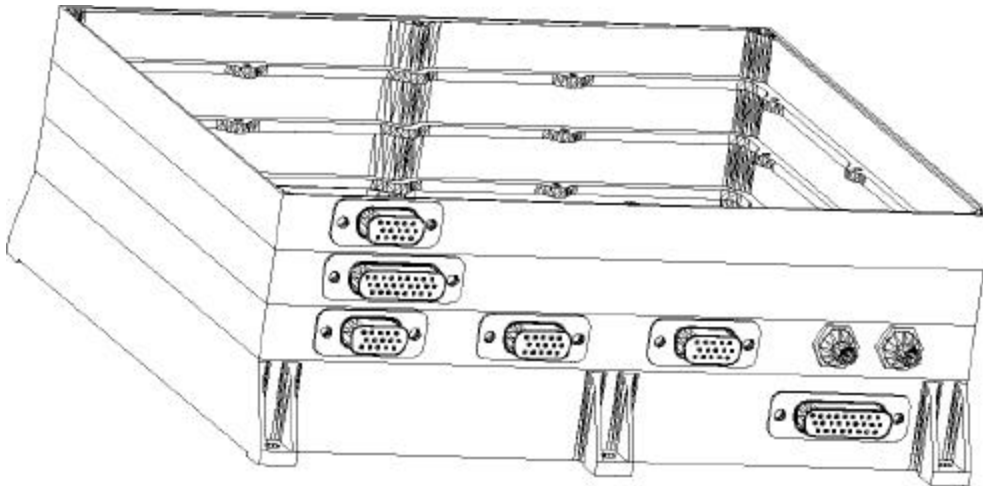

Figure 1 – IDPU Assembly

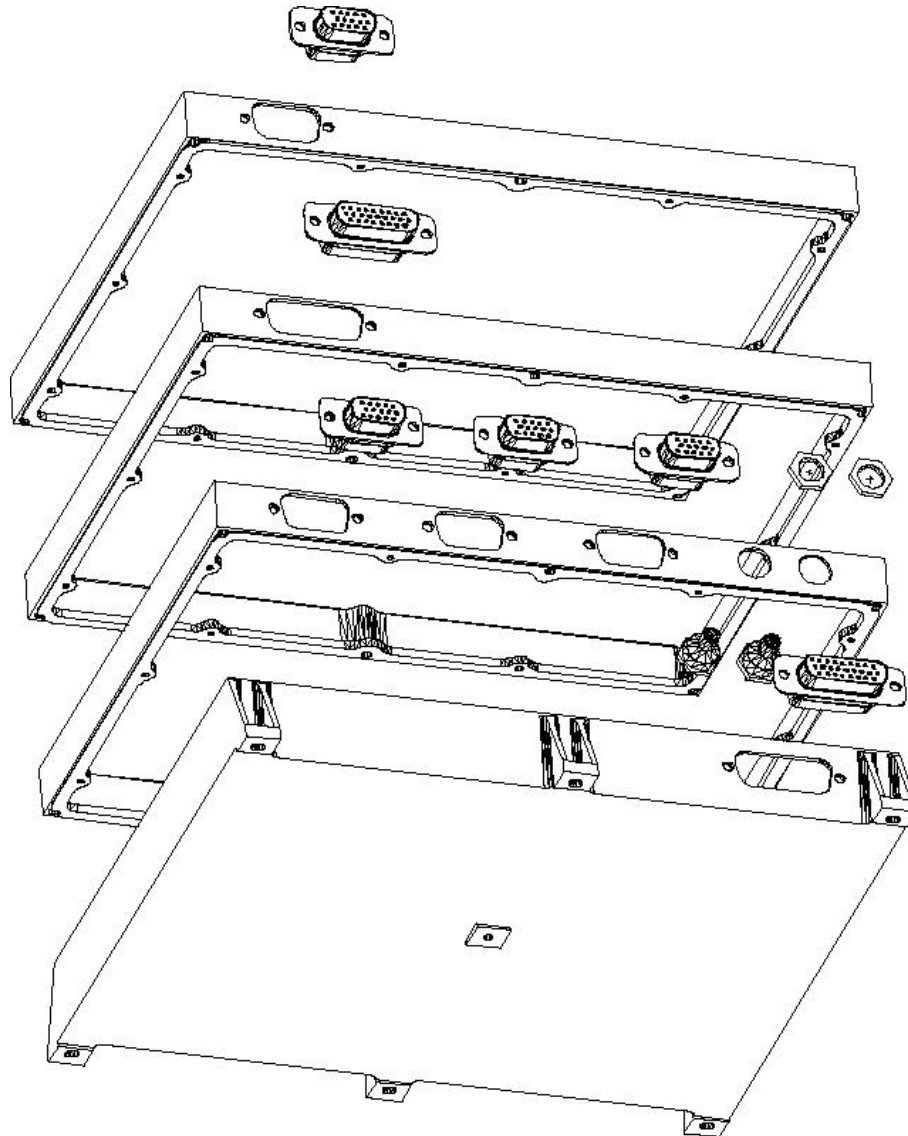

Figure 2 - IDPU Exploded View

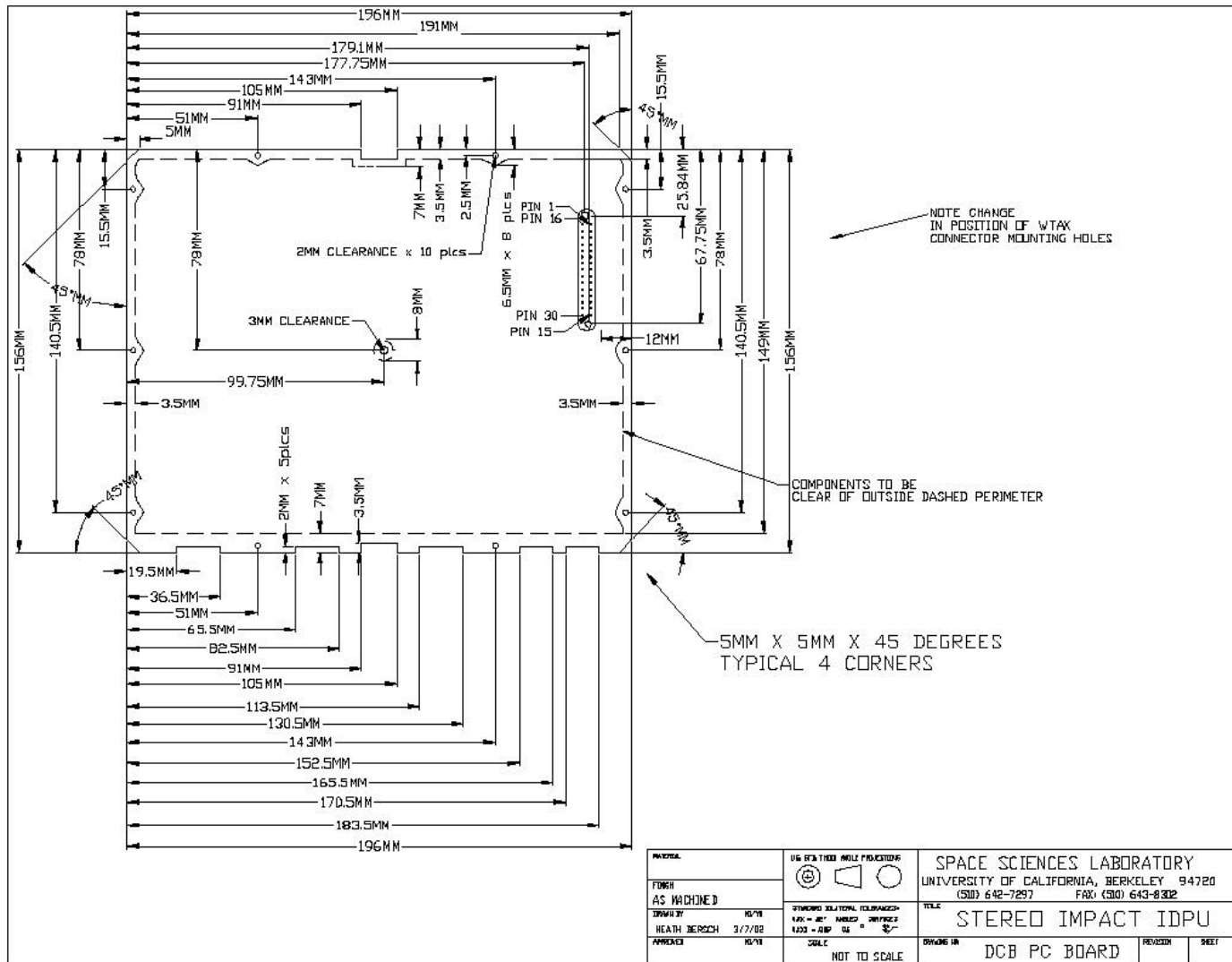

Figure 3 – Data Controller Board Outline

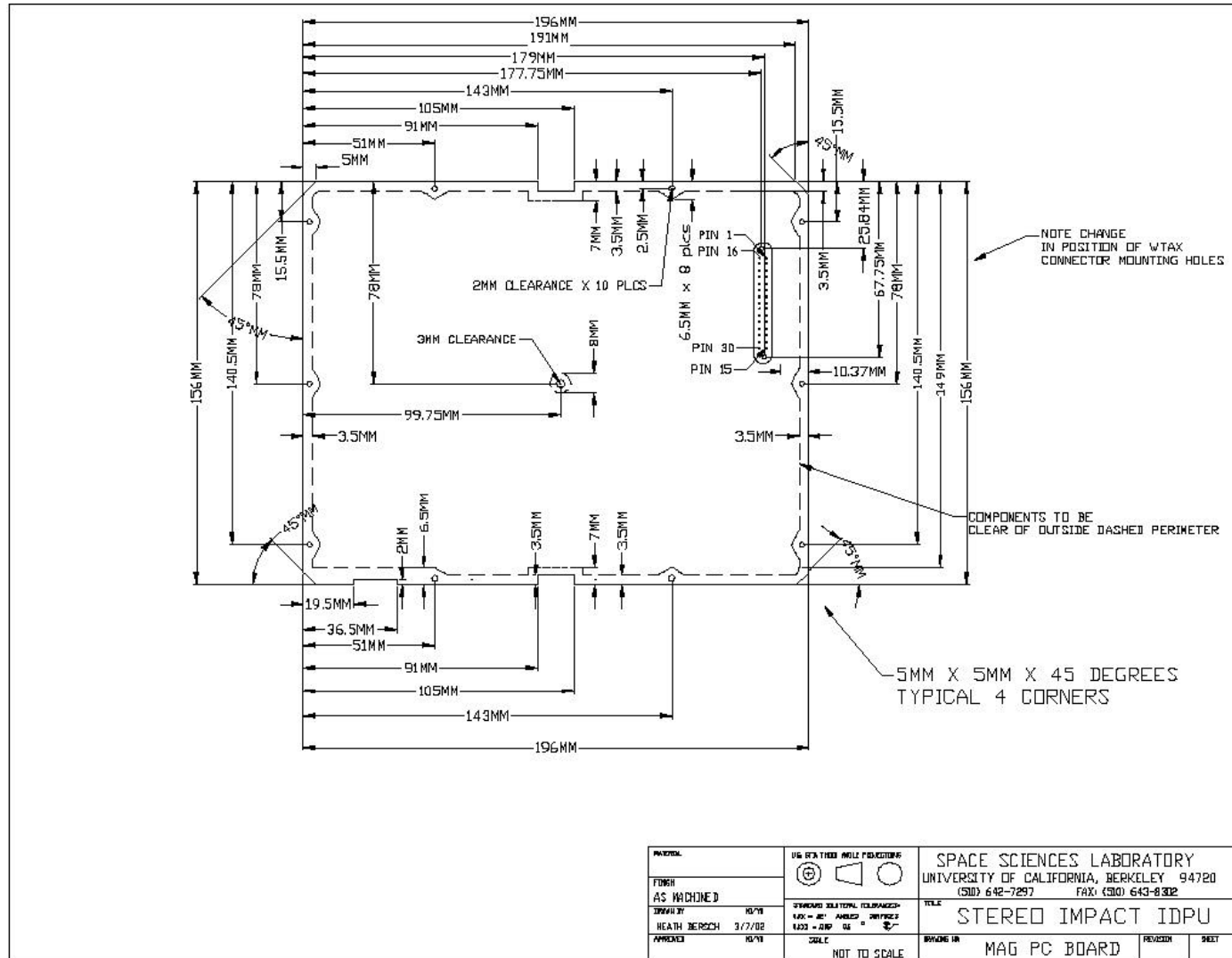

Figure 4 – MAG Board Outline

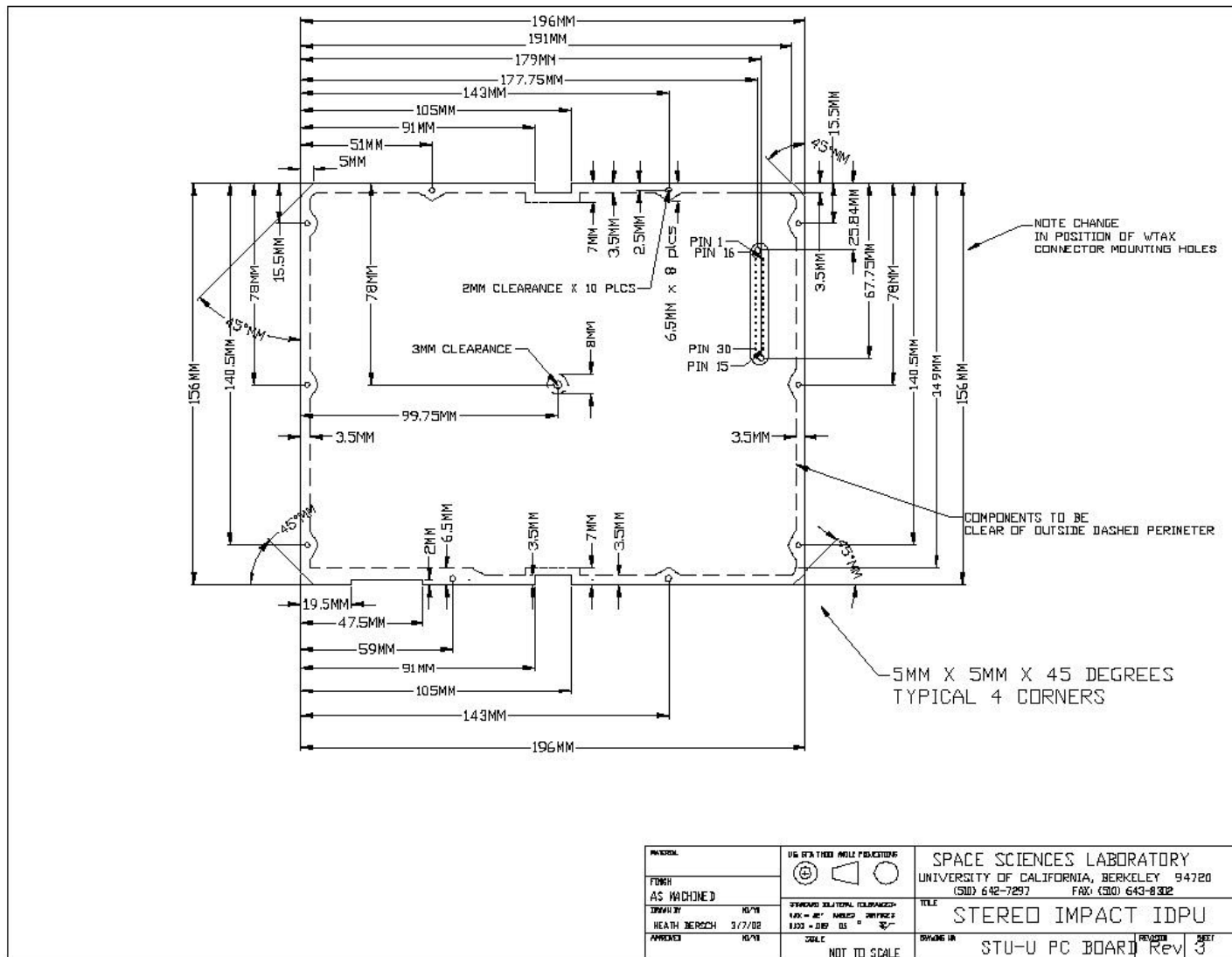

Figure 5 – STE-U Board Outline

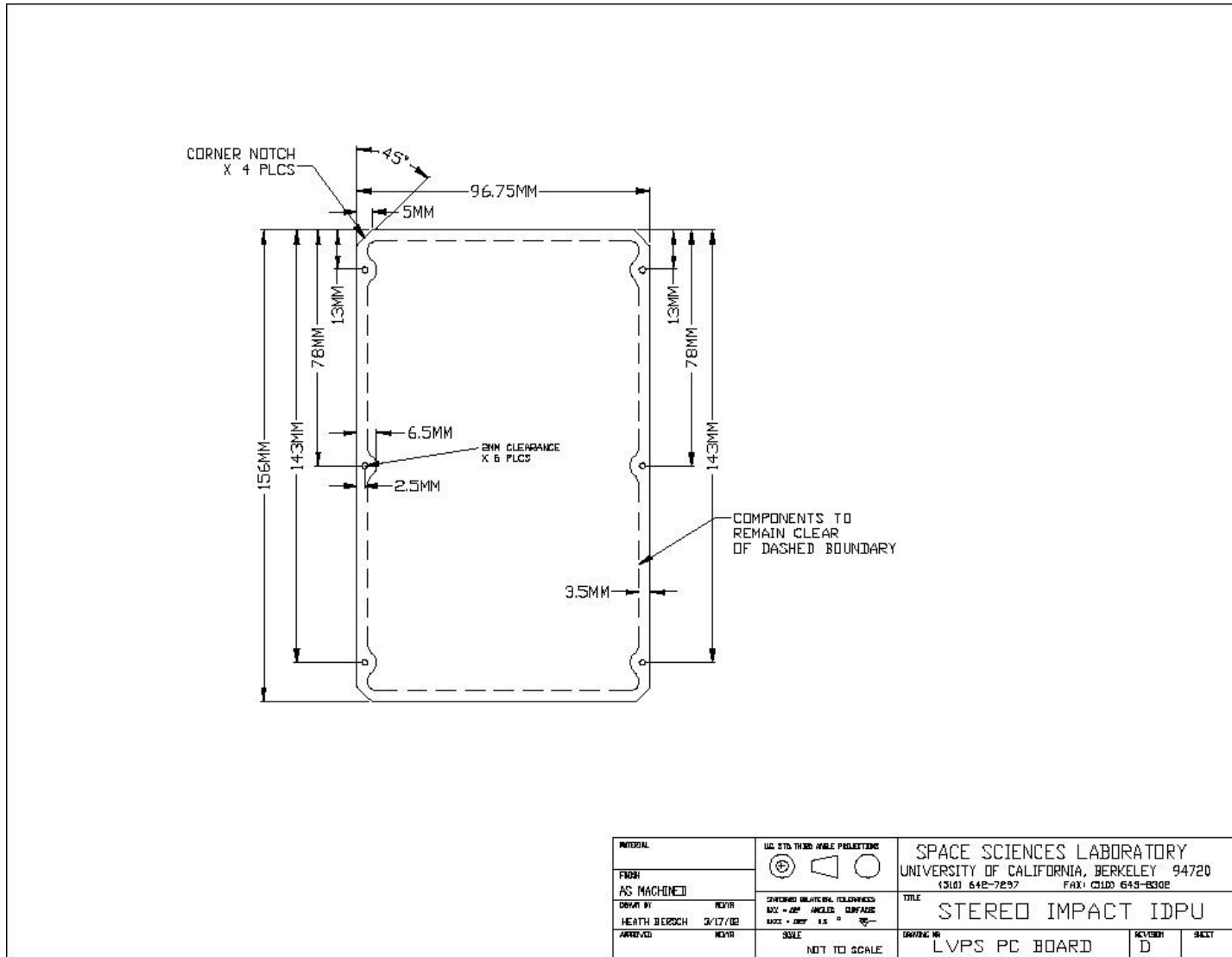

Figure 6 – LVPS Board Outline

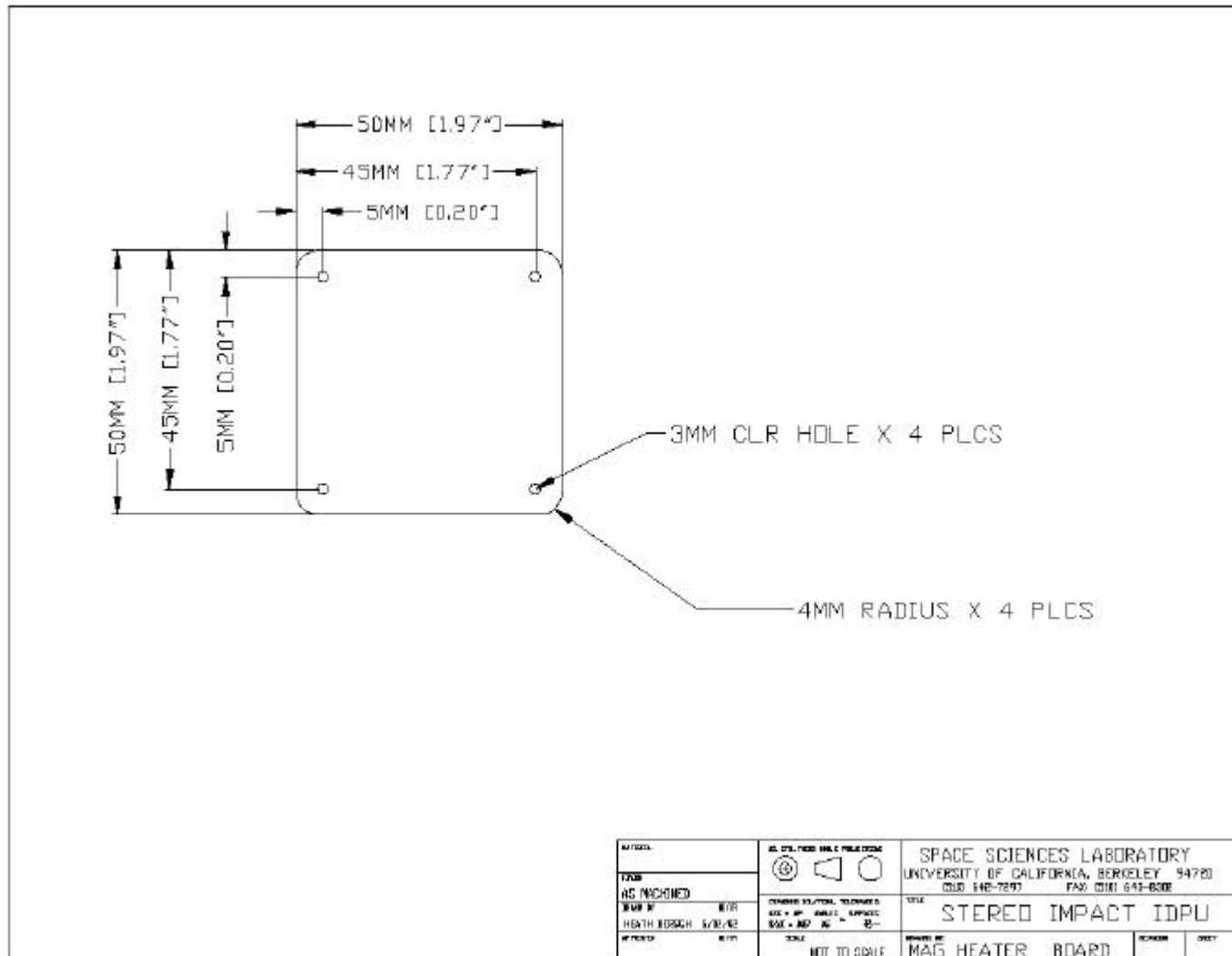

Figure 7 – Mag Heater Footprint

4. Internal Connector

The boards are connected together with “stacking” connectors, Airborn type WTAX30SAP27. See the Airborn catalog online at:

<http://www.airborn.com/pdf/wseries/w.pdf>

These connectors consist of a connector body with female sockets, plus long pins that go through the board and plug into the next connector below. The pin length is designed for 15mm board-to-board spacing. When soldering the connectors into the PWB, care needs to be taken not to get solder on the mating part of the pin. The pins have a small amount of compliance. When soldering the connectors into the boards, the connectors need to be placed accurately so that the pins will mate with the next board.

4.1. Internal Connector Pinout

Pin 1 = +12V analog (from LVPS to MAG, STE-U)
Pin 16 = -12V analog (from LVPS to MAG, STE-U)
Pin 2 = +5V analog (from LVPS to STE-U)
Pin 17 = -5V analog (from LVPS to STE-U)
Pins 3, 18 = AGND (from LVPS to MAG, STE-U)
Pins 4 = MagHeaterControl (from MAG to Mag Heater Supply)
Pin 19 = MagHeaterControlReturn (from MAG to Mag Heater Supply)
Pin 5 = MagHeaterPower (from MAG to Mag Heater Supply)
Pin 20 = MagHeaterPowerReturn (from MAG to Mag Heater Supply)
Pin 6 = HKPMagTemp (analog housekeeping from MAG to STE-U)
Pin 21 = HKPMagHeater (analog housekeeping from MAG to STE-U)
Pin 7 = MAGCLK (from DCB to MAG)
Pin 22 = MAGCMD (from DCB to MAG)
Pin 8 = MAGTLM (from MAG to DCB)
pin 23 = STEUCLK (from DCB to STE-U)
Pin 9 = STEUCMD (from DCB to STE-U)
Pin 24 = STEUTLM (from STE-U to DCB)
Pin 10, 25 = spare
Pins 11,26 = +2.5VD (from LVPS to DCB, STE-U)
Pins 12,27 = DGND (from LVPS to DCB, MAG, STE-U)
Pins 13,28 = +5VD (from LVPS to DCB, MAG, STE-U)
Pins 14,29 = GND-T (from LVPS to DCB)
Pins 15,30 = +5VT (from LVPS to DCB)

4.2. Signal Characteristics

The analog housekeeping signals should be conditioned with respect to AGND in the range +/-5V. The CLK/CMD/TLM signals are described in reference 4.

The supply voltages are regulated to $\pm 10\%$, and have less than 20mv p-p ripple. Note that these supplies have significant supply impedance, and so the voltages will vary with load over the indicated range. They may also sag momentarily in response to transient loads outside the range (in particular +12V may drop a few volts when the STE door is actuated). The electronics need not perform in spec, but should not be damaged by this.