

STEREO/IMPACT BOOM VERIFICATION PLAN
REV D 03 JUNE 2003

STEREO/IMPACT BOOM VERIFICATION PLAN

Revision Log

Revision	Date	Description
-	19 November 2002	Baseline Release
A	23 January 2003	Incorporated GSFC Comments; Added Table of Contents, provided more detail to testing
B	03 February 2003	Added Appendix D & E (Vibration Input Spectrums)
C	31March2003	See Appendix F for Listing of Changes
D	02June2003	Incorporated APL/GSFC comments from 'C' Revision; as marked in text

Written By: W. Donakowski/R. Ullrich
UCB/SSL

Approved By: P. Turin
UCB/SSL

Approved By: D. Curtis
UCB/SSL

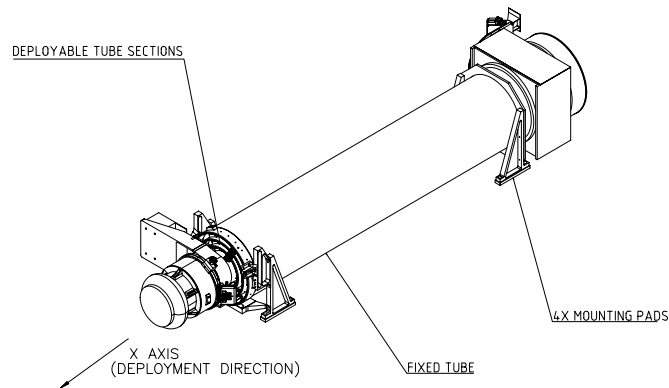

**Figure 1: STEREO/IMPACT BOOM
(SHOWN IN FLIGHT CONFIGURATION WITH INSTRUMENTS INSTALLED)**

STEREO/IMPACT BOOM VERIFICATION PLAN
REV D 03 JUNE 2003

1. Scope	6
2. Hardware Description and Assembly	6
2.1. Hardware Assembly Configurations	6
2.1.1. Flight Units: Configurations	7
2.1.2. Protoflight Unit Configurations	7
3. Hardware Heritage	8
4. Reference Documents	8
5. Qualification Methodology Overview	9
6. Documentation	9
7. Analysis and Design	9
7.1. FEM Analysis	9
7.2. Stress Analysis	9
7.3. Design Reviews	9
7.4. Stiffness Analysis	10
7.5. Deployment Force Margin Verification	10
7.6. FMEA Analysis	10
8. Documentation, Parts Selection, Build Controls	10
8.1. Parts and Materials Selection	11
8.2. Drawing Documentation and Control	11
8.3. Component Parts Inspection	11
8.4. Assembly Controls and Inspection	11
8.5. Final Assy Inspection	11
9. Mass Properties	11
10. Functional Check-Out	11
10.1. Deployment Functioning Overview	11
10.1.1. Full Deployment	11
10.1.2. First Motion	12
10.1.3. Full Deployment Walk-Out	12
10.2. Monitoring and Data Collection	12
10.3. Component Monitor	12
10.4. Deployment Rate	12
10.5. Boom Stiffness Verification	12
10.6. Boom Deployments Strategy	13
10.6.1. Full Deployments Matrix: Protoflight Unit (10 Full Deployments Total)	13

STEREO/IMPACT BOOM VERIFICATION PLAN
REV D 03 JUNE 2003

10.6.2. Full Deployments Matrix: Flight Model FM1 (6 Full Deployments Total)	13
10.6.3. Full Deployments Matrix: Flight Model FM2 (6 Full Deployments Total)	13
11. Spacecraft and Launch Vehicle Compatibility Testing.....	13
11.1. Vibration	13
11.2. Thermal Vac Testing	14
11.3. Resistivity	14
11.3.1. Surface Resistivity.....	14
11.3.2. Resistivity	14
11.4. EMI/EMC.....	14
11.5. Magnetics Cleanliness	14
11.6. Cable Harness Connectivity.....	14
11.7. Spacecraft End-to-End Electrical Connectivity	14
11.8. Magnetometer Alignment.....	14
11.9. Self-Induced Shock	14
11.10. Boom Deployment following Spacecraft Integration	15
12. Contamination	15
12.1. General Guidelines	15
12.2. Materials Outgassing	15
12.2.1. Materials Selection and Listing	15
12.2.2. TQCM Monitored Bakeout	15
12.2.3. Materials Samples Program.....	15
12.3. Clean Room and Facility Monitoring	16
12.3.1. Clean Room Operations.....	16
12.3.2. TQCM Monitoring.....	16
12.3.3. Empty Tank Certification	16
12.3.4. Post-Assembly Cleaning and Inspection	16
12.3.5. On-site Transportation and Handling	16
12.3.6. ESD Control Plan	16
13. Qualification Testing of Protoflight Unit.....	16
13.1. Functional.....	16
13.2. Magnetics Cleanliness	17
13.3. Mass Properties	17
13.4. Vibration Testing	17
13.5. Electrical Continuity Testing.....	17
13.6. Resistivity	17

STEREO/IMPACT BOOM VERIFICATION PLAN
REV D 03 JUNE 2003

13.6.1.	Surface Resistivity.....	17
13.6.2.	Resistivity	17
13.7.	Thermal Vacuum.....	17
13.7.1.	Hot/Cold Soaks	17
13.7.2.	Thermal Balance	18
13.8.	Deployment	18
13.9.	Self-Induced Shock	18
14.	Test Order and Flow	18
15.	Acceptance Testing of Flight Units	18
15.1.	Dimensional Inspection	18
15.2.	Mass Properties	18
15.3.	Functional.....	18
15.4.	Electrical Continuity Testing.....	18
15.5.	Magnetics Cleanliness	18
15.6.	Vibration Testing	18
15.7.	Thermal Vacuum.....	19
15.7.1.	Hot/Cold Soaks	19
15.7.2.	Thermal Balance	19
15.7.3.	Thermal Bake.....	19
15.8.	EMI/EMC.....	19
15.9.	Resistivity	19
15.9.1.	Surface Resistivity.....	19
15.9.2.	Resistivity	19
15.10.	Post-Integration Testing.....	19
15.10.1.	Magnetometer Alignment verification.....	20
15.10.2.	Deployment Walk-Out.....	20
15.10.3.	Spacecraft End to End Electrical Connectivity.....	20
15.11.	Test Order and Flow	20
16.	Data Collection and Documentation	20
17.	Verification Matrix.....	21
18.	Figure 2: Flow Chart, PROTOFLIGHT Unit (Reference: Section 13)	26
19.	Figure 3: Flow Chart, Flight Units (Reference: Section 15).....	27
20.	Figure 3: Flow Chart, Flight Units After Integration On Spacecraft (Reference: Section 15.10)	28
21.	Appendix A: Hardware Overview	30
22.	Appendix B: Boom Configuration.....	31

STEREO/IMPACT BOOM VERIFICATION PLAN
REV D 03 JUNE 2003

23.	Appendix C: Deployed Configuration	32
24.	Appendix D: Vibration Specifications, Qualification Testing (Protoflight Unit).....	33
24.1.	Testing Sequences	33
24.2.	Sine Survey (All Axes)	33
24.3.	Sine Strength (Protoflight Unit)	34
24.4.	Random (Protoflight and Flight Units).....	35
24.5.	Testing Sequencing	36
24.6.	Sine Survey	36
25.	Appendix F: Thermal Cycling Profile.....	37
26.	Appendix F: Change Log	38
27.	Appendix G: TBD Listing.....	39

STEREO/IMPACT BOOM VERIFICATION PLAN
REV D 03 JUNE 2003

1. Scope

This document defines the verification methods to be used in the design, development, build, and testing for Flight usage of the STEREO Deployable Booms. The STEREO/IMPACT Booms are designed, assembled, tested, and verified for Flight Use to all applicable project standards by the Space Sciences Lab at the University of California, Berkeley (UCB).

2. Hardware Description and Assembly

The STEREO Boom mechanical assembly consists primarily of a compact nested series of composite tubes, mechanical releasing devices, cable harnesses, and blankets. The primary requirement of the device is to provide a compact structure during satellite integration, test, and launch and to deploy in orbit to extend the magnetometer approximately 3 meters from the spacecraft, and the SWEA / STE-D 1m further.

The Boom Assy has two configurations, Stowed and Deployed. The overall dimensions of the assemblies, in both configurations, are as shown in Appendix A. The entire unit weighs approximately 12.1 Kg.

The system was designed for deployment in zero gravity and may not be deployed at one G without offsetting counterweights attached to a vertical offload fixture. The deployment takes place by on-board mechanical devices and electronics; the unit is a one-way device and must be restowed manually. Restowing is only performed to a UCB procedure by cognizant UCB engineers.

2.1. Hardware Assembly Configurations

The Boom Assembly, dependent on activity, will have different assembly configurations based on hardware being added and/or removed as appropriate. This includes full-up flight assembly, assembly with blankets removed, with instruments removed, for example. The following matrix is a listing of all useable Assembly Configurations that will be used in the verification testing program.

STEREO/IMPACT BOOM VERIFICATION PLAN
REV D 03 JUNE 2003

2.1.1. Flight Units: Configurations

(X=Component included in Configuration; O=Component omitted in Configuration.)

#	Configuration	Where Used	Boom	Cables	Mass Dummies	Instruments	Blankets	Thermal Mounting Isolators	Remarks
1	Flight First Build	Mass Props, Magnetic Cleanliness, Air Deploys, Surface Conductivity, Stiffness	X	X	X	O	O	O	
2	Environmental Testing	Vibration, T-V, Vacuum Deployment, EMI/EMC	X	X	X	O	O	O	
3	Pre-Ship	Bakeout, Cleaning, Shipping	X	X	O	O	O	O	Boom, Instruments, Blankets shipped separately
4	Flight	Integration onto S/C	X	X	O	X	X	X	Full Flight Configuration; Blankets installed separately following integration of Boom

2.1.2. Protoflight Unit Configurations

#	Configuration	Where Used	Boom	Cables	Mass Dummies	Instruments	Blankets	Thermal Mounting Isolators	Remarks
1	Protoflight First Build	Mass Props, Magnetic Cleanliness, air deploys, surface conductivity, Stiffness, Vibration, T-V, Vacuum Deployment	X	X	X	O	O X	O	Engineering Model Blankets installed for Thermal Balance Test Only
2	Pre-Storage	Cleaning, Bagging	X	X	O	O	O	O	

STEREO/IMPACT BOOM VERIFICATION PLAN
REV D 03 JUNE 2003

3. Hardware Heritage

The STEREO/IMPACT Boom Assembly shares a design and component Flight heritage of many previous programs built by UCB. Where possible, previous designs, components, analysis, and procedures will be utilized.

4. Reference Documents

Organization	Document	Title
APL	7381-9003	STEREO Environmental Definition, Observatory, Component and Instrument Test Requirements
APL	7381-9006	STEREO Contamination Control Plan
UCB	STEREO-IMPACT-PAIP	STEREO Performance Implementation Plan
UCB	IMPACTRequirementsVerification	STEREO/IMPACT Requirements Verification/Validation Plan
UCB	IMPACTEnvTestPLan	STEREO/IMPACT Environmental Test Plan
UCB	IMPACTCMPlan, STEREO/IMPACT	Document Configuration Management Plan
Swales	SAI-TM-STTE-001	IMPACT Deployable Contamination Test Results
APL	7381-9030	STEREO EMC Control Plan and EMI Performance
UCB	IMPACTPerformanceSpec_H	STEREO/IMPACT Performance Specification
APL	IMP-000-ICD	STEREO/IMPACT Interface Control Document
UCB	IMP-511-DOC	Boom Deployment Procedure
UCB	IMP-512-DOC	Boom Thermal Vacuum Test Procedure
UCB	IMP-513-DOC	Boom Stowing Procedure
UCB	ESDControlPlan_B	UCB ESD Control Plan

5. Qualification Methodology Overview

The verification methods used in the design, development, and building of the Booms will include all standard UCB/NASA program routines, including peer design reviews; hand engineering analysis; use of preferred parts, materials, and vendors; testing to written procedures and test reports; inspections by in-house staff and outside services; computer analysis for dynamics and stress; and final reporting documentation.

The verification process will consist of three main elements: analysis and design, qualification testing, and acceptance testing. All work to be performed by UCB personnel.

See Table I for listing of verification items, requirements, and methods.

6. Documentation

Due to the critical nature of the Booms for overall mission success, documentation will be maintained for all critical verification steps and will be available to all interested project parties.

Documentation shall consist of test plans, test procedures, engineering fabrication drawings, assembly procedures, test reports, test data sheets, unit logbooks, and photos. Engineering Documentation intended for use by outside personnel (vibration testing, fabrication drawings) shall be formal documents released via the UCB STEREO document release process. Master mark-ups and logbooks will be utilized in-house to speed development efforts where prudent. All documentation shall be maintained by UCB and be made available electronically where possible. Relevant Build and Test data shall be delivered with Flight Units as part of a End Item Data Package (EIDP).

7. Analysis and Design

7.1. FEM Analysis

Detailed FEM models of the Stereo Impact Boom were created for both stowed and deployed configurations. The deployed model was run with two different inter-segment joint stiffnesses. The deployed models consist of 11365 plate elements and 11224 nodes. The stowed model consists of 8560 plate elements and 8675 nodes. The analyses produced the first six vibration mode shapes and frequencies for each configuration.

For the stowed configuration, the FEM Analysis will be verified by actual vibration sine testing. UCB has provided completed FEM model to APL for incorporation into the higher-level spacecraft model and be supported by UCB as requested. For the deployed configuration, the FEM analysis will be verified by measuring first natural frequency only via one accelerometer and electronics at UCB.

7.2. Stress Analysis

Major components will be analyzed to ensure positive strength margins. Loading inputs will be based on expected inertial loads and operational loads as applicable. Stress analysis to make use of classical methods (Bruhn; Roark) and FEM computer modeling.

7.3. Design Reviews

The Boom Assy will be reviewed by UCB project personnel and outsider independent reviewers in several phases to ensure requirements and design intent. Review documentation will be dependent on formality of reviews; formal project (PDR/CDR) reviews will be complete with a design review package and subsequent meeting minutes including action items; informal peer reviews will utilize tabletop discussion and notes.

STEREO/IMPACT BOOM VERIFICATION PLAN
REV D 03 JUNE 2003

As of this release, four in-house UCB reviews have been completed. Review data packages are available at UCB upon request.

Design Reviews listing as follows.

Date	Title	Location	Remarks
November 2000	Peer Review #1	UCB	Initial Concepts Approved
September 2001	Preliminary Design Review	JHU/APL	
March 2002	Peer Review #2	UCB	
October 2002	Peer Review #3	UCB	
November 2002	Critical Design Review	JHU/APL	
March 2003	Peer Review #4	UCB	

7.4. Stiffness Analysis

Analysis of the Deployed Boom stiffness will be made by classical hand means, computer FEM means, and test measurements of similar STEREO specific hardware (prototypes and engineering models).

7.5. Deployment Force Margin Verification

A key component of a successful in-flight Boom Deployment relies on large ratios of output (Stacer) force compared to Boom tube deployment drag. Calculations and test data shall be used to quantify and optimize each parameter to ensure large margins. The minimum ratio for all Flight units in the worst case (test verified) is 2.25 (per GEVS Section 2.4.5.3). Force Ratio is defined as Force Available/Force Required. In the specific case of the Boom deployment, Force available is Stacer Output and Force Required is tube deployment drag. (Note Force Margin is defined as Force Ratio minus 1.0.)

As a final verification of this key parameter, all units will be test verified following Flight build and again following all environmental testing. These first built/post-test Force Ratios shall be compared to verify no loss of Boom performance.

7.6. FMEA Analysis

A FMEA (Failure Modes Effects Analysis) shall be performed by APL to survey possible failure modes, apply trade studies of mitigation, and uncover any overlooked characteristics of the design. This analysis will be done informally and will result in a documented report. The FMEA will explore the issues of incomplete deployment, locked-up tube deployment, and unlocked state, failure of monitors, temperature effects, FOD, Tube buckling and other characteristics. UCB shall provide input (design information, test data, heritage data, analysis) to this APL effort as requested.

8. Documentation, Parts Selection, Build Controls

8.1. Parts and Materials Selection

Where possible, parts and materials will be used of type with recent Flight heritage. Parts and materials listing will be maintained, available for inspection, and submitted to GSFC for evaluation. All parts are scrutinized for conformance to vacuum applicability, thermal environment, and compatibility with mating parts.

8.2. Drawing Documentation and Control

All parts shall be fabricated to engineering drawings consistent with MIL-STD-100, ANSI Y14.5 and UCB/STEREO Configuration Management Plan (IMPACTCMPlan). Drawings shall be formally released; all revisions shall be revision controlled by the cognizant UCB engineer and be made available to the Project if requested.

8.3. Component Parts Inspection

All incoming hardware will be inspected prior to use. Inspection to consist of visual inspection, logging and review of certifications and test data and in conformance to UCB Performance Assurance Implementation Plan (PAIP). Critical parts will be completely inspected prior to further processing.

8.4. Assembly Controls and Inspection

All critical assembly and test procedures will have documented procedures produced prior to start of work. Travelers consisting of procedures, certs, and drawings will be maintained with the flight hardware.

8.5. Final Assy Inspection

Flight units will have a final inspection to verify: dimensions on interfaces and envelope, mass properties, and overall quality. Closeout photographs will extensively document the final flight build.

9. Mass Properties

Flight Units will have mass properties measured, including total mass, center of gravity (both stowed and deployed configurations), and Moment of Inertia. Mass will be accurate within 100 grams, Center of Gravity within 5 mm, and Mol within 2%.

10. Functional Check-Out

10.1. Deployment Functioning Overview

10.1.1. Full Deployment

The Boom Assembly will undergo a large number of test deployments to verify functionality. Full deployment is defined as actuation via powering the SMA pin puller, Stacer actuation, and full deployment and lock of all Boom sections to full length. All full deployments shall be made with the Boom unit in the vertical position and with counterweights to offset gravity loading ("G-Negated"). The Protoflight Boom will be deployed throughout the course of its development no less than 10 full, successful deployments. The Flight Units will be deployed a minimum of 4 times.

10.1.2. First Motion

'First Motion' activation—power up of the SMA actuator to allow small (10mm or less) movement in the retraction pin—will be performed on the two Flight Units during Thermal Vacuum testing. This First Motion Activation verifies proper actuating mechanism pin retraction without the logistical difficulty of full Boom deployment and restowing.

10.1.3. Full Deployment Walk-Out

The other type of deployment that will be performed is a Full Deployment Walk-Out in which the Boom is fully deployed horizontally using the full Flight configuration with GSE equipment and technicians guiding and supporting the gravity loading. This walk-out test will verify Boom functionality late in the Instrument flow as well as verify no interferences with other Spacecraft Flight hardware.

10.2. Monitoring and Data Collection

Deployments will be monitored as completely as possible, depending on test locality. All in-air deployments will have real-time visual inspections, and rate monitoring. In-vacuum deployments will be visually verified in-situ and the deployment rate measured.

10.3. Component Monitor

Where useful, individual components will be monitored to determine baseline characteristics (SMA current, etc.) for Flight and Protoflight units. This shall include net force on the Boom by way of a load cell and electronics measuring net force as a function of distance (deployment).

10.4. Deployment Rate

The Deployment rate will be measured on all Units at all deployments. There is no requirement for the deployment rate; the design goal is 1 meter per second.

10.5. Boom Stiffness Verification

All Flight Booms will be tested for actual stiffness following full deployment. Stiffness verification to consist of: 'Dead Band' movement with Boom in Locked configuration; resonant Sine test (first natural frequency measured with mass models in place of instruments) using accelerometer and associated electronics; and Force Deflection and pointing accuracy measurement at the end of the Boom.

STEREO/IMPACT BOOM VERIFICATION PLAN
REV D 03 JUNE 2003

10.6. Boom Deployments Strategy

The Booms shall be fully deployed as detailed in the following matrices.

10.6.1. Full Deployments Matrix: Protoflight Unit (10 Full Deployments Total)

Designator	Goal	Environment	Location	Test/Measure/Verify
PM-DP1	Protoflight Build Tuning	Air	UCB	Stacer/Tube Interface, Build, Assembly Integrity, Troubleshoot
PM-DP2		Air	UCB	
PM-DP3	Baseline Properties Characterization	Air	UCB	Deploy Force, Deploy Rate, Cable Harness Connect, Mass Props Deployed, Stiffness, Force Deflection, Deployed First Natural Frequency, Pointing Stability
PM-DP4		Air	UCB	
PM-DP5		Air	UCB	
PM-DP6		Air	UCB	
PM-DP7	Self-Induced Shock 1	Air	UCB	Functionality, Deployment rate and force
PM-DP8	Self-Induced Shock 2	Air	UCB	Functionality, Deployment rate and force
PM-DP9	T-V Hot (post-vibe)	Vacuum	UCB	Functionality, Deployment rate and force
PM-DP10	T-V Cold (post-vibe)	Vacuum	UCB	Functionality, Deployment rate and force

10.6.2. Full Deployments Matrix: Flight Model FM1 (6 Full Deployments Total)

Designator	Goal	Environment	Location	Test/Measure/Verify
FM1-DP1	Flight Build Tuning	Air	UCB	Stacer/Tube Interface, Build, Assembly Integrity, Troubleshoot
FM1-DP2		Air	UCB	
FM1-DP3	Baseline Properties Characterization	Air	UCB	Deploy Force, Deploy Rate, Cable Harness Connect, Mass Props Deployed, Stiffness, Force Deflection, Deployed First Natural Frequency, Pointing Stability
FM1-DP4		Air	UCB	
FM1-DP5	T-V Hot (post-vibe)	T-V	UCB	Functionality, Deployment rate and force
FM1-DP6	Walk-Out on S/CT-V Cold (post-vibe)	Air/T-V	UCB	Functionality, Deployment rate and force
FM1-DP7	Walk-Out on S/C	Air	APL	EMI/EMC Test Measurements on S/C and Interference check of Blankets and other Spacecraft Components

10.6.3. Full Deployments Matrix: Flight Model FM2 (6 Full Deployments Total)

Designator	Goal	Environment	Location	Test/Measure/Verify
FM2-DP1	Flight Build Tuning	Air	UCB	Stacer/Tube Interface, Build, Assembly Integrity, Troubleshoot
FM2-DP2		Air	UCB	
FM2-DP3	Baseline Properties Characterization	Air	UCB	Deploy Force, Deploy Rate, Cable Harness Connect, Mass Props Deployed, Stiffness, Force Deflection, Deployed First Natural Frequency, Pointing Stability
FM2-DP4		Air	UCB	
FM2-DP5	T-V Cold (post-vibe)	T-V	UCB	Functionality, Deployment rate and force
FM2-DP6	Walk-Out on S/CT-V Cold (post-vibe)	Air/T-V	APLUCB	EMI/EMC Test Measurements on S/C and Interference check of Blankets and other Spacecraft Components Functionality, Deployment rate and force
FM2-DP7	Walk-Out on S/C	T-V	APL	EMI/EMC Test Measurements on S/C and Interference check of Blankets and other S/C components

11. Spacecraft and Launch Vehicle Compatibility Testing

11.1. Vibration

Vibration Testing shall be performed on all units at an outside vendor to verify Boom dynamic and structural adequacy. All testing to be consistent with GEVS requirements and APL provided coupled loads analysis. All vibration testing to be performed with Booms in Stowed configuration. See Appendices D and E for Vibration Spectrums.

11.2. Thermal Vac Testing

The Protoflight and Flight Units will undergo Vacuum testing, including bake out, thermal balance, deployment, and thermal cycling. All Thermal Vacuum Testing to be performed at UCB in a custom designed STEREO Boom Environmental Chamber. This new chamber will allow pump down to hard vacuum, thermal cycling (hot and cold), and full deployment under vacuum. Complete Thermal Vacuum test plan as contained in UCB Document "STEREO Boom Assy Thermal Vacuum Test Description". See Appendix for Thermal Cycles details.

11.3. Resistivity

11.3.1. Surface Resistivity

Following Flight build, exterior Boom surfaces will be checked in various locations on the exposed outer surfaces to verify a surface resistivity of less than 10^8 ohms / sq. for Flight Units.

11.3.2. Resistivity

To verify adequate grounding of the Protoflight unit, the Boom shall be checked for Resistivity to ensure 10 Kohm maximum between any two points on the Boom.

11.4. EMI/EMC

A full EMI/EMC test will be performed on the Boom suite (with instruments installed) to verify electromagnetic compatibility with Spacecraft requirements. Testing to be performed at outside facility. In addition, a compatibility EMC 'self check' will be made of the Booms following integration onto the Spacecraft.

11.5. Magnetics Cleanliness

To verify all Boom components are non-magnetic, a 'Magnetics Cleanliness' test shall be performed at UCB during and following all Boom assembly activities.

11.6. Cable Harness Connectivity

To ensure cable harness (Spacecraft to Instruments) integrity,

11.7. Spacecraft End-to-End Electrical Connectivity

As part of the integration activities, UCB shall provide a GSE Flight-like SMA Actuator (with connectors) to the Spacecraft vendor for electrical connectivity check-out as deemed appropriate.

11.8. Magnetometer Alignment

Verification shall be made of the final Magnetometer Alignment with requirement of alignment knowledge with +/- 1 degree.

11.9. Self-Induced Shock

Boom deployment will result in self-induced shocks as the deploying Boom sections lock into position at each interstage as well as reaching end of travel limit. Per GEVS 2.4.4.1 and 7381-9003 (paragraph 2.4.4) the Boom will undergo self-induced shock testing with instruments installed to verify they will present no degradation to the Boom itself from these nominal events. This test shall be performed twice on the Protoflight Boom.

11.10. Boom Deployment following Spacecraft Integration

A Walk-Out Deployment following integration to the Satellite will be performed for both Flight units.

12. Contamination

12.1. General Guidelines

Flight hardware will be assembled clean prior to arrival at test facility. For the majority of the testing, the Components shall be maintained in a Class 10,000 Clean Room or better. For short periods (loading/unloading into chamber, short transitions) the Components may be exposed to Class 100,000 Environment. The Flight Hardware shall be double-bagged with Llumalloy bagging material whenever outside a Class 10,000 clean room following thermal vacuum bakeout.

In an effort to establish baseline contamination data, an engineering Boom unit was tested for contamination by Swales Aerospace. The Test results stated 'contamination levels for all samples were below the level 300 goal set for the test. Barring differences between the flight and engineering units, the Booms will not generate enough particle contamination during deployment to pose a threat to the contamination sensitive instruments on STEREO'. See referenced Swales document for complete test data.

12.2. Materials Outgassing

12.2.1. Materials Selection and Listing

Boom materials will make use of low Outgassing materials throughout as defined in NASA NRP 1124. A complete listing of the materials used in the Boom shall be maintained by UCB. This listing has already been provided to the GSFC materials branch for evaluation and comment. [Any failure to meet outgassing requirements \(less than 1% TML and .1% CVCM\) will require a waiver request approval from APL prior to use.](#)

12.2.2. TQCM Monitored Bakeout

In addition to proper material selections, the final Flight units will be vacuum baked for a minimum of 24 hours at 60 degrees C or until TQCM rate increase is less than 1 Hz/Hr/Hr for 5 consecutive hours.

12.2.3. Materials Samples Program

UCB shall maintain samples for all materials whose outgassing properties may require validations at a later date if outgassing events occur. Specifically, all materials requiring mixing (2 part epoxies, pottings, coatings, and the like) and all composite materials will have samples maintained by UCB. All samples to be dated and serialized to verify traceability to Flight

STEREO/IMPACT BOOM VERIFICATION PLAN
REV D 03 JUNE 2003

Hardware Components. Unless requested, UCB does not plan to routinely test each sample for outgassing characteristics.

12.3. Clean Room and Facility Monitoring

12.3.1. Clean Room Operations

During all Clean Room operations, a calibrated particle counter will periodically survey the environment near the Flight hardware to verify particle counts are sufficiently low.

12.3.2. TQCM Monitoring

During all vacuum testing, a minimum of one TQCM shall be provided by the Facility to constantly monitor NVR in the system.

12.3.3. Empty Tank Certification

Prior to the start of testing, the tank shall be cleaned by the facility and certified via TQCM means to verify cleanliness. Level of Cleanliness shall be less than 100 Hz/Hour with the TQCM at -20°C.

12.3.4. Post-Assembly Cleaning and Inspection

Following functional testing and prior to input to Vacuum Tank, the Booms shall be manually cleaned using vacuum cleaning with ULPA filtered vacuum and alcohol wipe. Following cleaning, the unit will be inspected for contamination with a black light and recleaned as necessary in compliance with APL Contamination Control Plan, 7381-9006.

12.3.5. On-site Transportation and Handling

Following assembly and clean certification, when the Boom assembly is transported outside of a clean environment, the unit will be double-bagged with Llumalloy (anti-static) bagging material. When possible, inner bag will be back filled with Nitrogen. At no times will the bag be opened outside of a clean room. For handling, shipping, and integration activities, UCB shall design and fabricate custom GSE as required to prevent any possible damage to Flight units.

12.3.6. ESD Control Plan

All work (build, handling, testing, transport) of the Boom hardware shall be done in compliance with the UCB ESD Avoidance Procedure document, ESDControlPlan. These procedures include the 'standard' use of ESD Avoidance protocol including the use of ground straps where necessary, grounding all Flight Hardware when electronics are present, proper material selection, and control of the laboratory environment.

13. Qualification Testing of Protoflight Unit

13.1. Functional

A minimum of 8 full deployments of the Protoflight unit will be made in air. Additionally, the Protoflight unit will be deployed under vacuum in the vertical position two times; once hot and

once cold. Mass Models will be installed to recreate the mass of the instruments that will not be present.

13.2. Magnetics Cleanliness

Finished units will be tested to verify no magnetic components are incorporated in Boom

13.3. Mass Properties

Mass properties shall be measured following Assembly in both Stowed and Deployed Configurations.

13.4. Vibration Testing

Vibration Testing to Protoflight Levels shall be performed on the Protoflight Boom unit. Testing to consist of sine survey, sine strength, and random inputs. Vibration testing to be performed to verify FEM analysis as well as structural adequacy of the Boom design. All vibration testing to be performed in the Stowed configuration. Test inputs per [GEVS-STEREO Document APL 7381-9003](#) requirements and will be contained in a separate UCB test procedure. See Appendix D for Vibration Input spectrums and test specifics.

13.5. Electrical Continuity Testing

Cable Harness electrical continuity shall be verified following assembly, during all actual deployments in air, and again following deployment.

13.6. Resistivity

13.6.1. Surface Resistivity

Following Flight build, exterior Boom surfaces will be checked in various locations on the exposed outer surfaces to verify a surface resistivity of less than 10^8 ohms / sq. for Flight Units.

13.6.2. Resistivity

To verify adequate grounding of the Protoflight unit, the Boom shall be checked for Resistivity to ensure 10 Kohm maximum between any two points on the Boom.

13.7. Thermal Vacuum

The Protoflight unit will undergo Vacuum testing, including bake out, thermal balance, deployment, and thermal cycling. All Thermal Vacuum Testing to be performed at UCB in a custom designed STEREO Boom Environmental Chamber. This new chamber will allow pump down to hard vacuum, thermal cycling (hot and cold), and full deployment under vacuum. Complete Thermal Vacuum test plan as contained in UCB Document "STEREO Boom Assy Thermal Vacuum Test Description".

13.7.1. Hot/Cold Soaks

The Hot/Cold Soaks will consist of raising the unit temperature to Survival Hot Temp, lowering to Survival Cold temp, followed by cycling between operational hot temp and operational cold temp. See Appendix F for cycles details. A total of 7 cycles will be made. The Hot/Cold Soaks will be

STEREO/IMPACT BOOM VERIFICATION PLAN
REV D 03 JUNE 2003

performed with the unit in the Stowed configuration. All Thermal Vacuum Hot/Cold soaks as defined in UCB Document IMPACTEnvTestPlan (Environmental Test Plan).

13.7.2. Thermal Balance

Protoflight unit to undergo Thermal Balance Testing at UCB to verify the thermal model. Test configuration to be in Stowed configuration with at least 8 thermal monitors located on the Flight hardware, and run in the expected cold case. Protoflight Boom to be complete with blankets, cables, and appropriate dummies for missing instruments. No Sun Simulator or facsimile will be possible at the UCB facility.

13.8. Deployment

The Protoflight Unit will be deployed in vacuum following Thermal Vacuum testing. Goal of testing is to verify no degradation in Boom motion following Thermal Testing.

13.9. Self-Induced Shock

The Protoflight unit (with instruments installed) will be deployed twice to verify this self-induced shock will present no degradation to the Boom itself.

14. Test Order and Flow

See following Flow Charts for test flow sequencing

15. Acceptance Testing of Flight Units

15.1. Dimensional Inspection

Flight Units will be 100% dimensionally inspected to verify all exterior packaging geometry as well as attach interfaces. A set of drawings with 'As-Built' dimensions will be produced.

15.2. Mass Properties

Mass properties shall be measured following Assembly in both Stowed and Deployed Configurations.

15.3. Functional

Deployments will be made to a written UCB procedure for all Flight Units. ~~Deployments shall be made in air only for the Flight units. Deployments as defined in Section 10.6.~~

15.4. Electrical Continuity Testing

Cable Harness electrical continuity shall be verified following assembly, during all actual deployments in air, and again following deployment.

15.5. Magnetics Cleanliness

Finished units will be tested to verify no magnetic components are incorporated in Boom.

15.6. Vibration Testing

Flight Units will undergo vibration testing. Vibration testing to be performed at an outside facility and will be performed with the unit in the Stowed configuration. Tests to include Sine Sweep to verify modal response, Sine Burst for strength testing, and Random. A separate Vibration Test Procedure will be written detailing final tests to be run, including levels and durations. See Appendix E for Vibration Input Data and test specifics.

15.7. Thermal Vacuum

Thermal Vacuum Testing will be made on each completed Flight Assy with instruments installed.

15.7.1. Hot/Cold Soaks

The Hot/Cold Soaks will consist of elevation to Survival Hot, then lowered to Survival Low Temp, then cycled between Operational Hot Temp and Operational Low Temp as detailed in Appendix F. The Hot/Cold Soaks will be performed with the unit in the Stowed configuration. All Thermal Vacuum Hot/Cold soaks as defined in UCB Document IMPACTEnvTestPlan (Environmental Test Plan).

15.7.2. Thermal Balance

None--Thermal Balance will be performed on Protoflight unit only.

15.7.3. Thermal Bake

All Flight Units will undergo thermal bake out following all testing. Bakeout to be made under vacuum at 60 degrees C for a minimum of 24 hours or until TQCM rate increase is less than 50 Hz/Hr/Hr for 5 consecutive hours or for a maximum of 48 hours. Prior to the bakeout, a pre-certification phase shall be performed in which the empty chamber is baked out at 60 degrees C with TQCM monitoring. This pre-certification is done to determine the baseline background contamination levels per APL 7381-9006. Following Flight Units Bakeout, a post-certification bake shall be performed on an empty chamber to verify post-certification TQCM readings are similar to pre-certification readings.

15.8. EMI/EMC

A full EMI/EMC test will be performed on the Boom Assy suite (with Instruments) on Flight Unit #1. Following integration onto the Spacecraft, both Flight units will receive a self-compatibility check-out.

15.9. Resistivity

15.9.1. Surface Resistivity

Following Flight build, exterior Boom surfaces will be checked in various locations on the exposed outer surfaces to verify a surface resistivity of less than 10^8 ohms / sq. for Flight Units.

15.9.2. Resistivity

To verify adequate grounding of the Protoflight unit, the Boom shall be checked for Resistivity to ensure 10 Kohm maximum between any two points on the Boom.

15.10. Post-Integration Testing

Following integration on the Spacecraft, the two Flight booms will have the following check-outs performed:

15.10.1. Magnetometer Alignment verification

Using calibrated equipment, the Magnetometer Alignment will be recorded to achieve position knowledge of +/- 1 degree.

15.10.2. Deployment Walk-Out

A non-activated Boom Deployment Walk-Out shall be performed to verify no interference with other Spacecraft hardware.

15.10.3. Spacecraft End to End Electrical Connectivity

The Spacecraft vendor, using the UCB provided Flight-like GSE SMA Actuator, will be able to perform and electrical connectivity check-out as deemed appropriate.

15.11. Test Order and Flow

See following Flow Charts for test flow sequencing.

16. Data Collection and Documentation

All assembly procedures, certification logs, process certifications, test procedures and reports will be maintained and collected in one location by UCB.

STEREO/IMPACT BOOM VERIFICATION PLAN
REV D 03 JUNE 2003

17. Verification Matrix

Section	Item	Requirement Summary	Verification Method	Affected End Units	Closeout Tracking Milestone
7.3	Design Reviews	Conduct Device Peer Review at UCB	Informal Table-Top Design Review with SSL Peers	Protoflight and Flight	Review Minutes and action Items. Two reviews completed; review packages available for inspection at UCB.
7.2	Stress Analysis	All Margins of Strength Positive using SF=1.3 on Yield and SF=1.4 on Ultimate; all Composite Components SF=2.0	Classical Stress Analysis (Hand and FEM)	Protoflight and Flight	Stress/Strength Analysis Included in EIDP (End Item Data Package)
7.6	FMEA Analysis	Determine Failure Modes and Mitigation Strategy	Survey of possible failure modes, risks, and mitigation approaches	Protoflight and Flight	UCB inputs to APL Analysis completed.
8.2	Drawing Documentation and Control	Configuration Integrity	Drawing consistent with ANSI-Y14.5 and MIL-STD-100; formal drawing release process	Protoflight and Flight	Engineering Drawing Package including complete Fabrication drawings, Project Drawing Tree. All drawings available to Project by request.

STEREO/IMPACT BOOM VERIFICATION PLAN
REV D 03 JUNE 2003

Section	Item	Requirement Summary	Verification Method	Affected End Units	Closeout Tracking Milestone
12.2.1	Outgassing	Less than 1% TML and less than .1% CVCM	Selection from NASA 1124 only; Materials Usage Agreement (MUA) waiver submitted for unlisted	Protoflight and Flight	As reported in Project Materials List and (if necessary) MUA waivers. Materials list has been provided to GSFC for evaluation.
8.1	Parts and Materials Selection	Component Adequacy	Use of heritage and Preferred parts listing	Protoflight and Flight	As reported in Project Materials List and Bill of Materials
8.3	Component Parts Inspection	Qualified/Heritage Parts	Visual Inspection by UCB	Prototype and Flight	Inspection Reports, Certifications Logging Included in EIDP (End Item Data Package)
8.4	Assembly Controls and Inspection	Configuration Integrity and Traceability	Assy Documentation	Protoflight and Flight	Hardware Build Traveler Paperwork Included in EIDP (End Item Data Package)
8.5	Final Assy Inspection	Final inspection for drawing and project conformance	Visual Inspection by UCB	Protoflight and Flight	As-Built Dimensions Documentation, QA Overview Report, Non-Conformances A/R Included in EIDP (End Item Data Package)
8.5	Dimensional (Stowed and Deployed)	Visual Inspection	Visual Inspection by UCB	Protoflight and Flight	Inspection Report showing As-Built critical dimensions Included in EIDP (End Item Data Package)
9	Mass Properties (Stowed and Deployed)	Determine Mass and CG (both Stowed and Deployed)	Measurements by UCB	Flight	Mass Properties Report Included in EIDP (End Item Data Package)
10.1	Functional	Functional Check (Deployment)	Full Deployments by UCB to UCB Procedure	Protoflight and Flight	Test Record

STEREO/IMPACT BOOM VERIFICATION PLAN
REV D 03 JUNE 2003

Section	Item	Requirement Summary	Verification Method	Affected End Units	Closeout Tracking Milestone
7.5	Stacer Output Force	Verify Output Force	Measured by UCB	Protoflight and Flight	Test Record Included in EIDP (End Item Data Package)
7.5	Boom Deployment Drag	Measure Cumulative Drag Forces on Boom Deploy	Measured by UCB during Full Deployment	Protoflight and Flight	Test Record Included in EIDP
-	SMA Release Force	Measure Output Force	Calibrated Measurement by Vendor	Protoflight and Flight	Vendor Provided Certificate of Conformance Included in EIDP (End Item Data Package)
11.3	Surface Resistivity	Surface conductivity of less than 10^8 ohms / sq	Calibrated Measurement by UCB	Protoflight and Flight	Test Record Included in EIDP
10.5	Pointing Accuracy	Magnetometer Orientation Knowledge within +/- 1 degree	Visual Inspection/ calibrated measurement by UCB	Protoflight and Flight	Test Data Sheet Included in EIDP
11.9	Self-Induced Shock	Test required to verify any self-induced shock due to Boom deployment does not degrade unit	Testing at UCB (2 deployments)	Protoflight	Test Record
11.5	Magnetics Cleanliness	Verify no magnetic components	Measurement following Flight Build by UCB	Protoflight and Flight	Test Data Sheet Included in EIDP
10.5	Boom Stiffness	Verify As-Built Boom Stiffness in Deployed State >.5 Hz	Force Deflection, Resonant First Mode Measurement	Protoflight and Flight	Test Data Sheet Included in EIDP (End Item Data Package)

STEREO/IMPACT BOOM VERIFICATION PLAN
REV D 03 JUNE 2003

Section	Item	Requirement Summary	Verification Method	Affected End Units	Closeout Tracking Milestone
12.3.4	Contamination	Verify VCHS+UV Condition for all Flight Units	Black Light, <u>White Light</u> , and <u>tape lift</u> Inspection of Flight Hardware; TQCM monitoring	Protoflight and Flight	Contamination Records Included in EIDP (End Item Data Package)
11.1	Strength Verification	Vibration Testing of Complete Assy	Vibration Testing	Protoflight and Flight	Vibration Test Report; Inspection to verify no damage
11.1	Dynamics Verification	Verify Dynamics properties	Vibration Testing	Protoflight and Flight	Vibration Test Report
11.4	EMI/EMC	EMI/EMC Compatibility with Spacecraft and other instruments	Full EMI/EMC test for Flight Unit #1; self compatibility check-out of both Flight Units following Integration onto Spacecraft	Flight	EMI/EMC Test Report Test Data Sheet at Integration Check-out on Spacecraft Included in EIDP
15.7.3	Bakeout	Adequate Bakeout of all units following Flight Build	TQCM monitoring TV bake at UCB	Protoflight and Flight	Bakeout Test Report, including durations, temperature profiles, and TQCM data
11.2	Thermal Vacuum	7 thermal cycles to 10 degrees beyond expected temperatures per GEVS	TV Testing at UCB	Protoflight and Flight	Thermal Vacuum Test Report, including durations, temperature profiles, and TQCM data

STEREO/IMPACT BOOM VERIFICATION PLAN
REV D 03 JUNE 2003

Section	Item	Requirement Summary	Verification Method	Affected End Units	Closeout Tracking Milestone
11.8	Magnetometer Alignment Test	Verify Magnetometer Knowledge within +/- 1 degree	Calibrated measurement	Flight Units following Integration	Test Record
11.7	Boom/Spacecraft Electrical Continuity	Verify End-To-End Continuity	Activate UCB-provided Flight-Like SMA Actuator at S/C integration	Flight Units	Test Record

STEREO/IMPACT BOOM VERIFICATION PLAN
REV D 03 JUNE 2003

18. **Figure 2: Flow Chart, PROTOFLIGHT Unit (Reference: Section 13)**

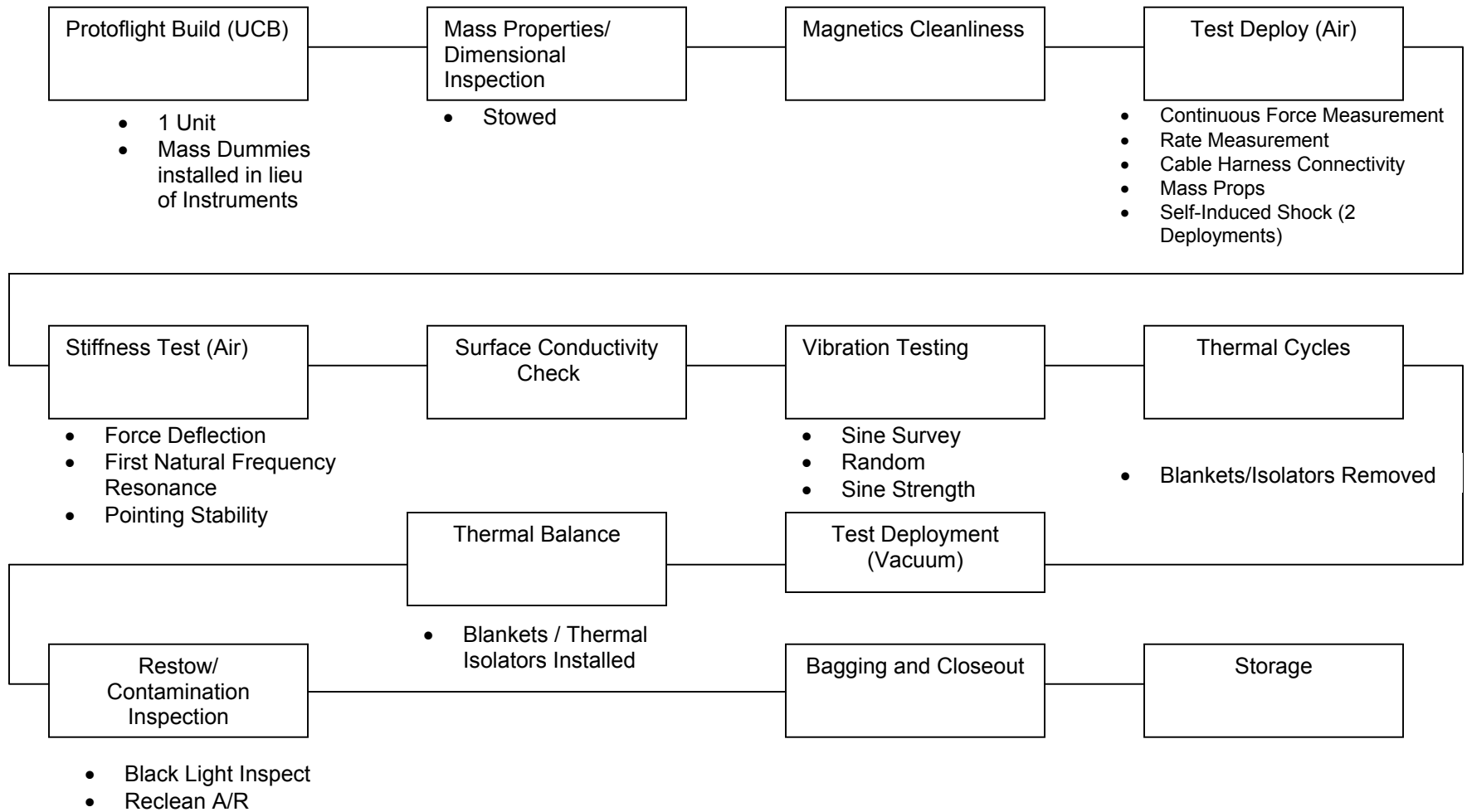

STEREO/IMPACT BOOM VERIFICATION PLAN
REV D 03 JUNE 2003

19. Figure 3: Flow Chart, Flight Units (Reference: Section 15)

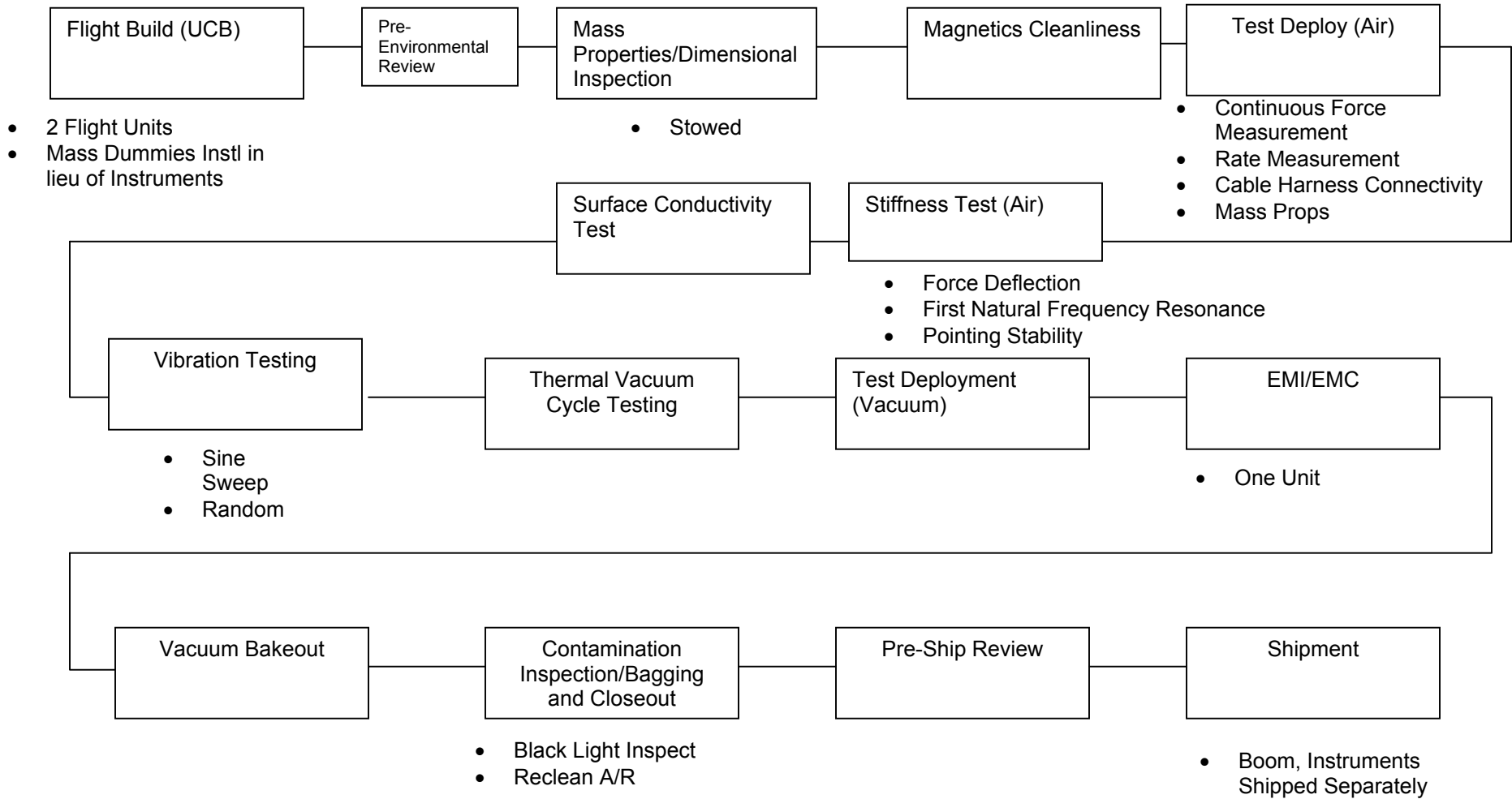

20. Figure 3: Flow Chart, Flight Units After Integration On Spacecraft (Reference: Section 15.10)

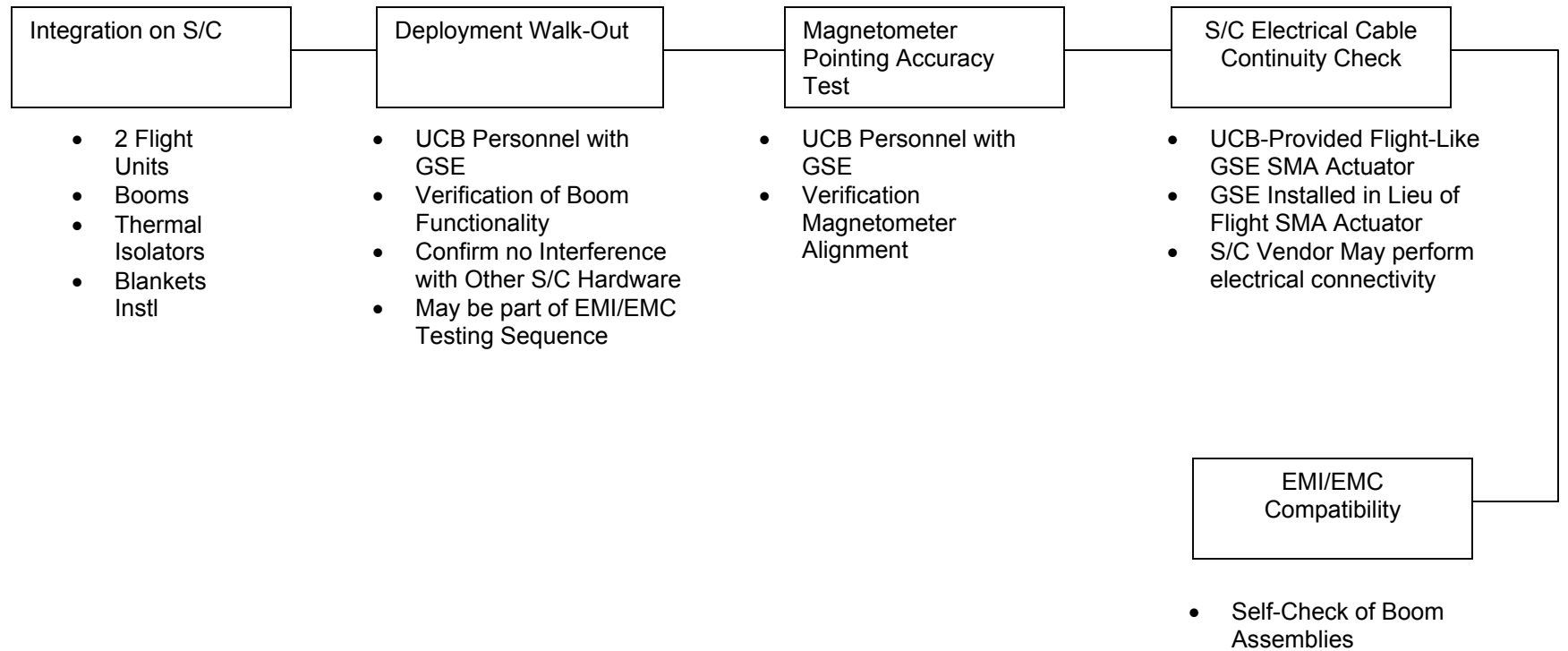

STEREO/IMPACT BOOM VERIFICATION PLAN
REV D 03 JUNE 2003

Testing Verification Matrix
for STEREO/IMPACT/Boom

Revision Date: 1/24/03
Revision Number: 6

Hardware Description		Test													Comments	
Level of Assembly	Item	Deploy Test, Room Temperature	Deploy test, Thermal Vac	Stiffness, Proof Load	Vibration, Sinusoidal	Vibration, Random	Self-Shock	Acoustics	Thermal Vacuum	Thermal cycle	Thermal balance	EMC/EMI	Magnetics	Bakeout		Contamination Inspection Deployment contamination
C	BB	X		X												
C	EM	X		X											X	Qual levels
C	PF/FS	X	X	X	X	X	X		X	X	X		X			Protoflight Levels
C	FM1	X	X	X	X	X		S	X	X		X	X	H	X	Protoflight Levels
C	FM2	X	X	X	X	X		S	X	X		S	X	H	X	Protoflight Levels

Legend:

Level of Assembly Unit Type

C = Component
I = Instrument

BB = Breadboard
EM = Engineering Model

Protoflight/Flight
PF/FS = Spare
FM1/FM2 = Flight Unit #1/#2

Key

X = Test required
A = Analysis
H = Test at higher level of assembly (with instruments)
S = Test at spacecraft level

STEREO/IMPACT BOOM VERIFICATION PLAN
REV D 03 JUNE 2003

21. Appendix A: Hardware Overview

Shown with Instruments Installed (all units in mm)

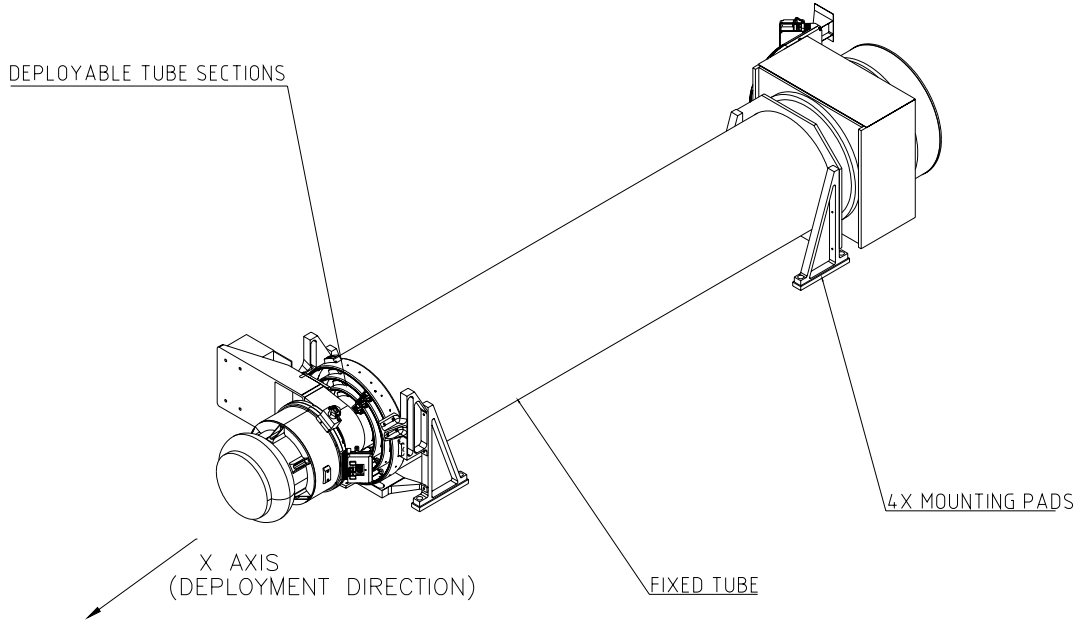

STEREO/IMPACT BOOM VERIFICATION PLAN
REV D 03 JUNE 2003

22. Appendix B: Boom Configuration

Shown with Instruments Installed (all units in mm)

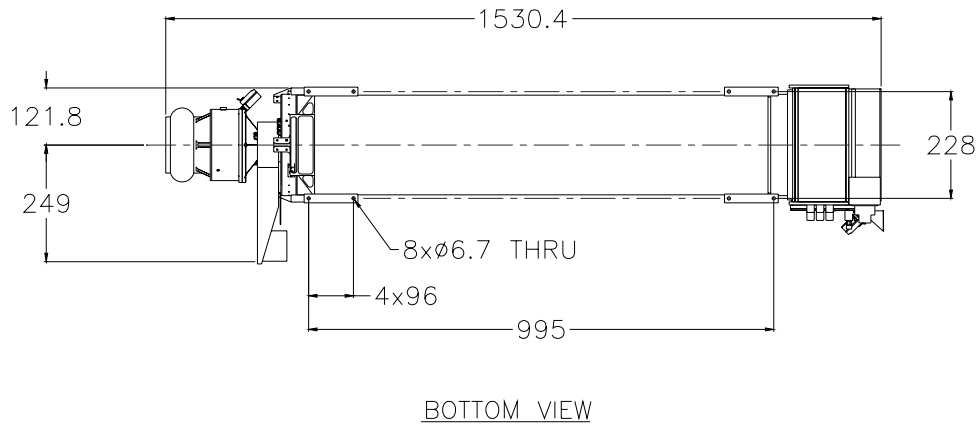
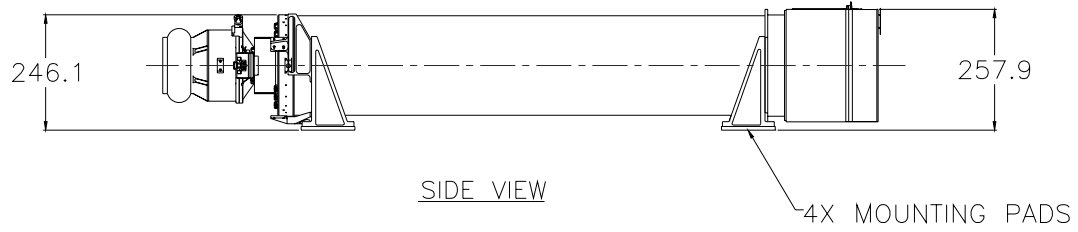

Stowed Configuration

23. Appendix C: Deployed Configuration

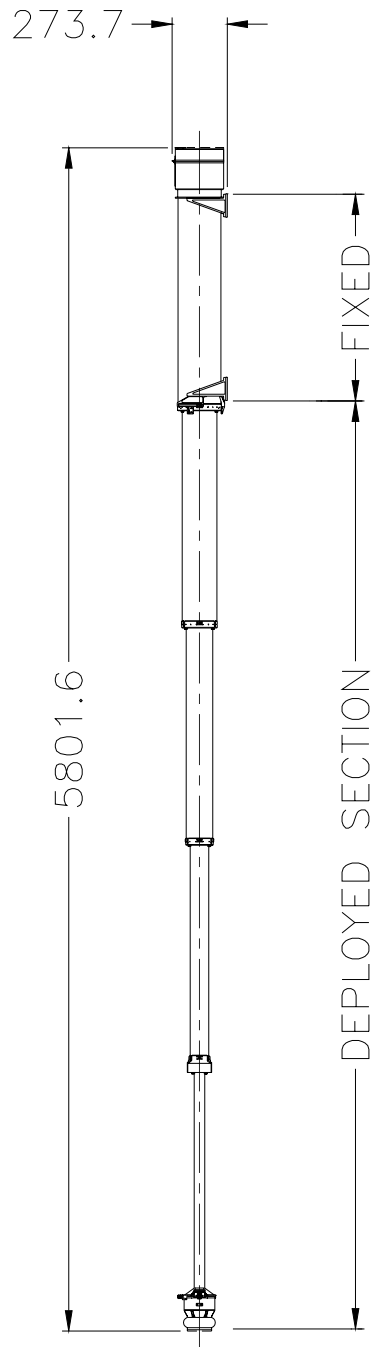

24. Appendix D: Vibration Specifications, Qualification Testing (Protoflight Unit)

24.1. Testing Sequences

Testing to be performed in following order; identical sequence in all axes. Axes order optional.

a.	Mounting on Vibration Table
b.	Visual Inspection
c.	Sine Survey #1
d.	Sine Strength Test
e.	Sine Survey #2
f.	Random Vibration
g.	Sine Survey #3
h.	Visual Inspection
i.	[Repeat, other two axes]

24.2. Sine Survey (All Axes)

Frequency (Hz)	Acceleration
5-2000	0.1 g

Rate: 4 Octaves/Minute

STEREO/IMPACT BOOM VERIFICATION PLAN
REV D 03 JUNE 2003

24.3. Sine Strength (Protoflight Unit)

Sine Strength Test
REF: APL 7381-9003 Rev A
Rate: 4 Octaves/Minute

Thrust Axis

Freq	G
5-7.4	[.5" DA]
7.4	1.4
23	1.4
25	16
27	16
29	1.4
100	1.4

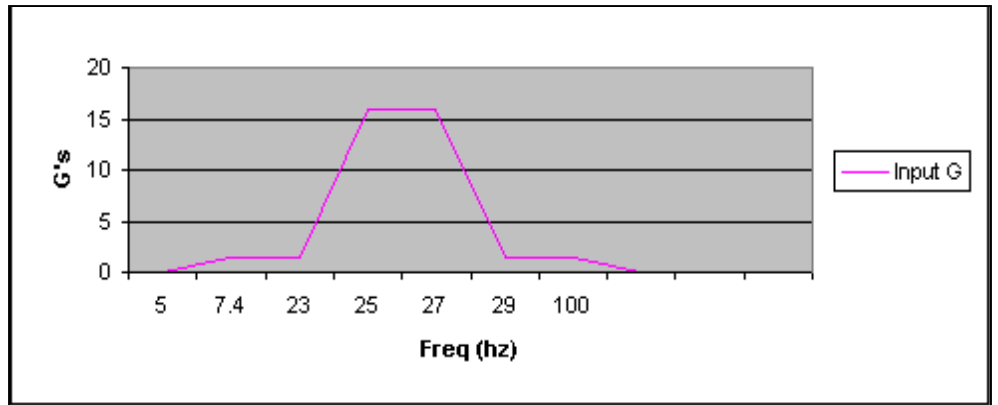

Lateral Axes

Freq	G
5-6.3	[.5" DA]
6.3	1
19	1
21	12
23	12
25	1
100	1

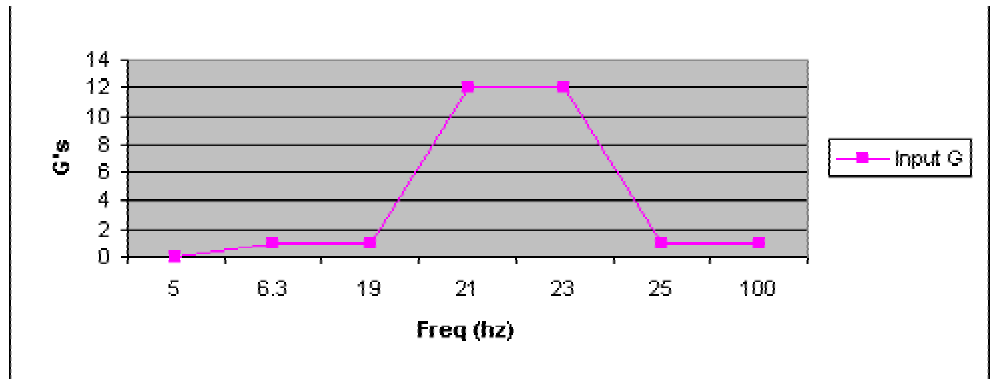

STEREO/IMPACT BOOM VERIFICATION PLAN
REV D 03 JUNE 2003

24.4. Random (Protoflight and Flight Units)

Random Vibration Specification						
STEREO BOOM						
REF: APL 7381-9003 REV A						
Duration: 60 Seconds						
Axis: Parallel to S/C Mounting Panel						
FREQ(Hz)	ASD(G ² /Hz)	dB	OCT	Slope dB/OCT	AREA	Acceleration Grms
20	0.0031	*	*	*	*	*
80	0.0500	12.08	2.00	6.04	1.31	1.14
800	0.0500	0.00	3.32	0.00	37.31	6.11
2000	0.0032	-11.94	1.32	-9.03	54.11	7.36

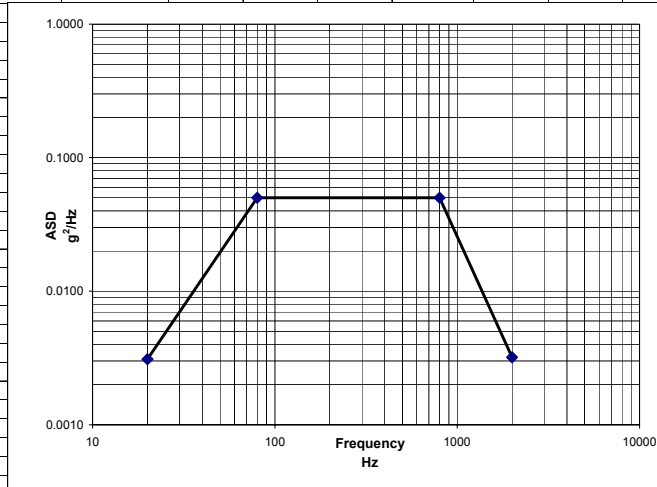

Random Vibration Specification						
STEREO BOOM						
REF: APL 7381-9003 REV A						
Duration: 60 Seconds						
Axis: Perpendicular to S/C Mounting Panel						
FREQ(Hz)	ASD(G ² /Hz)	dB	OCT	Slope dB/OCT	AREA	Acceleration Grms
20	0.0063	*	*	*	*	*
80	0.1000	12.01	2.00	6.00	2.63	1.62
800	0.1000	0.00	3.32	0.00	74.63	8.64
2000	0.0065	-11.87	1.32	-8.98	108.42	10.41

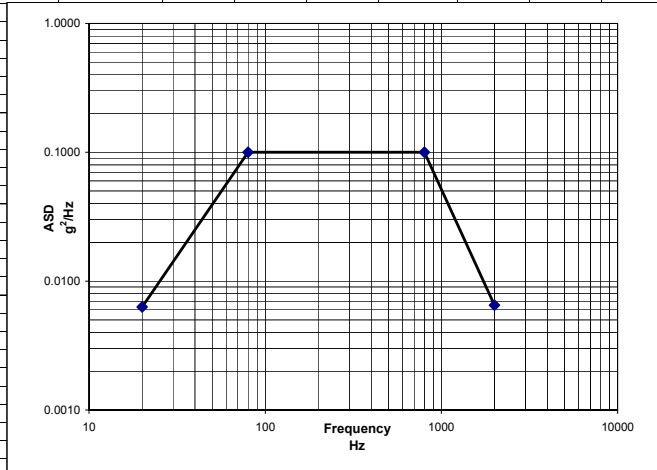

STEREO/IMPACT BOOM VERIFICATION PLAN
REV D 03 JUNE 2003

Appendix E: Vibration Specifications Acceptance Testing (Flight Unit)

24.5. Testing Sequencing

a.	Mounting on Vibration Table
b.	Visual Inspection
c.	Sine Survey #1
d.	Random Vibration
e.	Sine Survey #2
f.	Visual Inspection
g.	[Repeat, other two axes]

24.6. Sine Survey

Frequency (Hz)	Acceleration
5-2000	0.1 g

(All Axes)

Rate: 4 Octaves/Minute

STEREO/IMPACT BOOM VERIFICATION PLAN
REV D 03 JUNE 2003

25. Appendix F: Thermal Cycling Profile

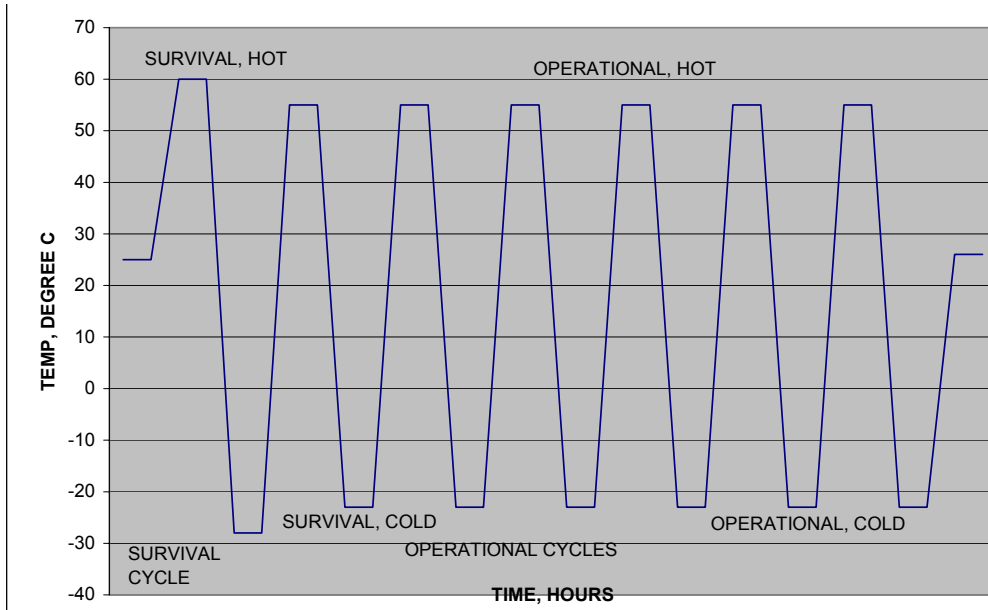

- Thermal Vacuum Test Cycles
- One Survival Cycle
 - 7 Operational Cycles
 - Transition Rates not to Exceed 3 Degrees C per Minute
 - Dwell Time at Temperature Extremes Minimum 4 Hours

Temperature Description	Temperature, Degrees C	Remarks
Survival, Cold	-28	All Temperatures preliminary (TBD). Final Temperature ranges to be determined following thermal analysis (ongoing as of this revision).
Survival, Hot	+65	
Operational, Cold	-23	
Operational, Hot	+60	

STEREO/IMPACT BOOM VERIFICATION PLAN
REV D 03 JUNE 2003

27. Appendix G: TBD Listing

The following TBD's are outstanding following the release of the revision:

Revision	Section/Issue	Responsible Organization
C	Appendix F: Final Operational and Survival Temperatures	Thermal Design/Swales/GSFC
D	Appendix F: Final Operational and Survival Temperatures TBD	Thermal Design/Swales/GSFC