

STEREO *IMPACT*

Intra Instrument Interface

IMPACTSerialInterface_G.doc
Version G – 2003-Apr-16

David Curtis, UCB IMPACT Project Manager

Document Revision Record

Rev.	Date	Description of Change	Approved By
A	2000-Jun-09	Preliminary Draft	-
B	2001-Mar-02	<ul style="list-style-type: none"> • Add MAG • Add SEP Command Rate Limitation 	-
C	2001-Oct-3	<ul style="list-style-type: none"> • Add STE-U • Add parity bit to commands • Add MAG exceptions 	-
D	2001-Oct-31	<ul style="list-style-type: none"> • Specify driver RC tuning to cable capacitance • Change sample time to h:m:s format 	
E	2002-Mar-7	<ul style="list-style-type: none"> • Clarify command parity bit • Set MAG telemetry message size to 4 16-bit words • Add details of MAG commanding 	
F	2002-Jun-19	<ul style="list-style-type: none"> • Change SEP command rate to 7ms minimum time between commands • Define the UTC clock (time of the Sample clock tic) • Refer to SIF spec for definition of SWEA/STE commands and messages. • Defines SEP message & command IDs • Defines SEP message transfer rate limits 	
G	2003-Apr-16	<ul style="list-style-type: none"> • Change SEP beacon message length to 144 bytes • Change SEP housekeeping message length to 272 bytes • Remove CCSDS packet header from SEP commands • Clarify polarity of signals • Add MAG control bit definitions 	

Distribution List

Dave Curtis, UCB
 Steve McBride, UCB
 Dorothy Gordon, Elf
 John Scheifele, GSFC (MAG)
 Alan Cummings, Caltech (SEP)
 Rick Cook, Caltech (SEP)
 Steven Turco, UNH (PLASTIC)

Table of Contents

Document Revision Record.....	i
Distribution List.....	i
1. Introduction.....	3
1.1. <i>Document Conventions</i>	3
2. Requirements.....	3
2.1. <i>Environment</i>	3
2.2. <i>Philosophy</i>	3
2.3. <i>EMC</i>	3
2.4. <i>Bitrate</i>	3
2.5. <i>Sample Timing</i>	3
2.6. <i>SEP Packet Time Stamps</i>	4
2.7. <i>Interaction Timing</i>	4
3. Overview.....	4
3.1. <i>Commands</i>	4
3.2. <i>Telemetry</i>	4
3.3. <i>Handshaking</i>	4
3.4. <i>Sample Clock</i>	4
4. Serial Interface Circuit.....	5
4.1. <i>Termination</i>	5
4.2. <i>Hysteresis</i>	5
4.3. <i>Power-off mode</i>	5
4.4. <i>Shields</i>	6
5. Command Interface.....	6
5.1. <i>Clocking edge</i>	6
5.2. <i>Synchronization</i>	6
5.3. <i>Data Stream Format</i>	6
6. Telemetry Interface.....	7
6.1. <i>Clock Edge</i>	7
6.2. <i>Synchronization</i>	7
6.3. <i>Data Stream Format</i>	7
7. Command Message Coding.....	7
7.1. <i>Sample Clock Message</i>	7
7.2. <i>Spacecraft Clock Message</i>	8
7.3. <i>Reset Command</i>	8
7.4. <i>SEP Command Packet Message</i>	8
7.5. <i>MAG Command</i>	8
8. Telemetry Message Formats.....	9

1. Introduction

This document describes the serial interface used between the IMPACT IDPU and the PLASTIC, SEP, SWEA/STE-D, STE-U, and MAG instruments on the STEREO spacecraft. This interface is used to send command and control information from the IDPU to the instruments, and for the instruments to send data and status to the IDPU.

1.1. *Document Conventions*

In this document, **TBD** (To Be Determined) means that no data currently exists. A value followed by **TBR** (To Be Resolved) means that this value is preliminary. In either case, the value is typically followed by a code such as UCB indicating who is responsible for providing the data, and a unique reference number.

2. Requirements

2.1. *Environment*

The IDPU and SEP are processor-based systems. PLASTIC, SWEA/STE-D, STE-U, and MAG are not, containing only logic. SEP communicates mostly in CCSDS packets, while PLASTIC, SWEA/STE-D, STE-U, and MAG mostly generate blocks of raw data, and mostly ingest register setting commands.

2.2. *Philosophy*

A common interface design is used to minimize development effort and allow the use of common development tools. The number of wires has been minimized at the cost of more logic at the sending and receiving ends; wires add to weight and complexity, while the interface logic is easily implemented in a small part of an FPGA.

2.3. *EMC*

EMC requirements dictate a clock that is a multiple of 50kHz, slew-rate limiting of the signals, voltage rather than current mode interface, and double-shielding of the harness grounded to case/signal ground at both ends.

2.4. *Bitrate*

A high data transfer rate is required; PLASTIC needs a significant fraction of 1Mbps to transfer its raw data to the IDPU.

2.5. *Sample Timing*

A method for synchronizing data sampling for the various instruments to a common time base may be required. This time base shall not be synchronized to the spacecraft clock.

2.6. **SEP Packet Time Stamps**

SEP requires knowing the spacecraft clock in order to time-stamp its packets. The spacecraft clock is in UT, with millisecond resolution. Some jitter (many milliseconds) is acceptable on the reconstruction of this clock.

2.7. **Interaction Timing**

Instruments shall be sufficiently self-contained that no high-speed interaction with significant timing requirements shall be required with the IDPU. The instruments shall sequence on their own based on the timing provided and control information transferred asynchronously over the command interface and the sample clock.

3. **Overview**

A three-wire serial digital interface will be used. A common continuous 1MHz clock signal, "CLK", is provided by the IDPU synchronizes the data transfer and is also the basis of the common sampling clock.

3.1. **Commands**

Commands from the IDPU to the instrument shall be formatted into 24 bit data words (8 bits of identification and 16 bits of information), and passed serially on the command signal "CMD". Start and stop bits shall be used to synchronize transmissions.

3.2. **Telemetry**

Data from the instrument shall be formatted into blocks of 16-bit words transferred serially over the data signal "TLM". Start gaps between messages and words synchronize transmissions.

3.3. **Handshaking**

No handshaking is planned. The IDPU shall be sized to ingest data as fast as the instruments can provide it. The instruments must buffer the commands as needed to keep up with several back-to-back commands, though the average command rate will be low. A failure of the synchronization scheme will result in a lost message that should be noted in the telemetry stream, but typically the message will not be repeated. For SEP, the command rate shall be limited to no more than one command word every 7ms to avoid overrunning the SEP command receiver. (7ms = 128Hz plus some jitter)

3.4. **Sample Clock**

Sampling timing is based on the 1MHz CLK signal, plus a sample command sent once a second to synchronize the sampling counters. This command shall be synchronized to provide a jitter-free sample clock. The command will contain a seconds counter to synchronize sampling that takes more than one second.

4. Serial Interface Circuit

Figure 1 shows the interface circuitry for the serial interface.

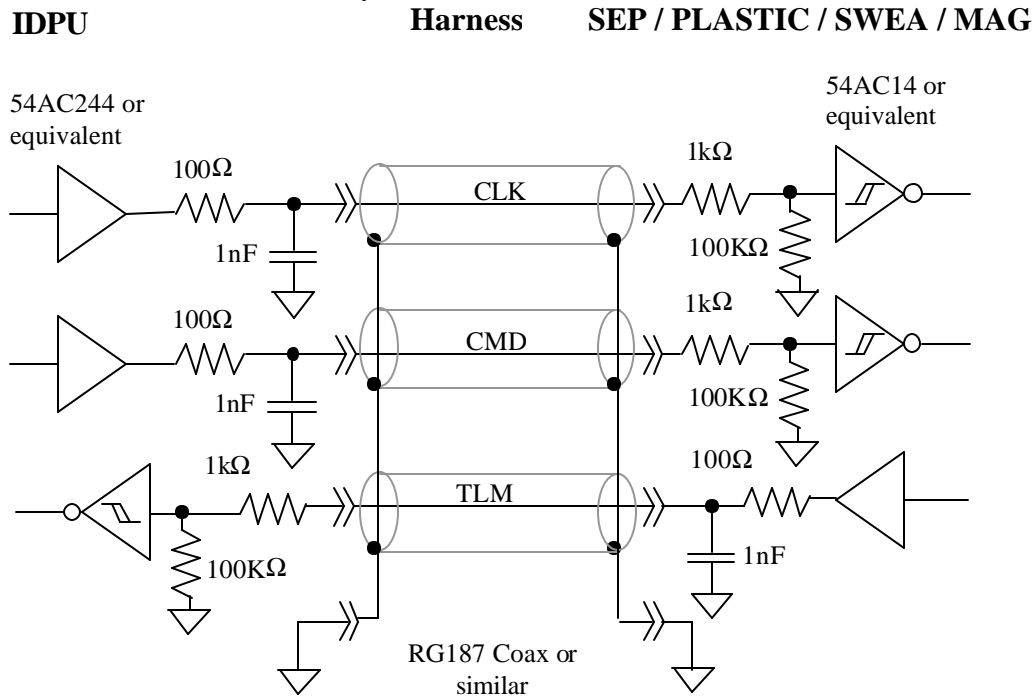

Figure 1 - Serial Interface Circuit

4.1. Termination

The RC circuit at the driving end provides series termination for the cable as well as 100ns RC time constant to remove the fast edges from the signals. The resistors at the receiving end protect the gate input and pull it to an inactive level when disconnected. The capacitor value shall be tuned as a function of cable capacitance to give a total capacitance of around 2nF. The driver may be any 54AC gate.

4.2. Hysteresis

The receive gates have hysteresis to provide noise immunity, nominally 54AC14. Note that this is an inverting gate; the signal levels described below are as measured on the harness. It is assumed that the interface logic following the 54AC14 makes up for the inversion.

4.3. Power-off mode

The IDPU shall output a low level on CLK and CMD when the instrument is powered off to avoid partially powering the instrument through the logic gate. Since the IDPU shall always be on whenever the instrument is on, no such logic is needed in the instrument end.

4.4. Shields

Only the first shield is shown. A common shield over this harness plus any other power or analog signals shall provide the second level of shielding. This shield shall also be grounded at both ends via the connector backshell.

5. Command Interface

Figure 2 shows the command interface timing. Note all signal polarities are as measured on the harness.

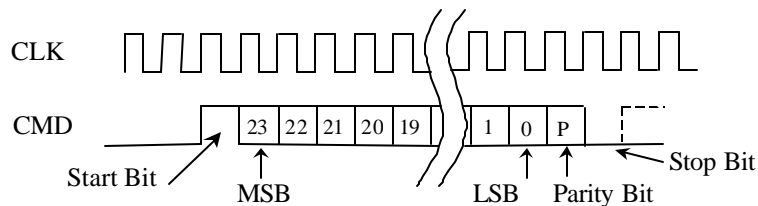

Figure 2 - Serial Command Timing

5.1. Clocking edge

The receiving circuit should clock in the data bits on the falling edge of CLK (to avoid a race between the CMD and CLK signals).

5.2. Synchronization

The system synchronizes by finding the first non-zero bit (the START bit), and verifies synchronization by the presence of a zero-value STOP bit. After a reset or loss of synchronization, the receiving system should look for 24 consecutive zero-level bits before starting to look for a start bit to avoid incorrect interpretation of a transfer in progress.

5.3. Data Stream Format

Commands are 24-bits long, preceded by a start bit, and followed by parity bit and a stop bit. The 24 bits are sent MSB first. The parity is odd and includes the 24 command bits but not the start bit, so that a command with all 24 bits zero would have the parity bit on. Commands can start on any rising edge of CLK, and any number of idle bit periods can occur between commands. The data is transferred Most Significant Bit (MSB) first. Messages consist of an 8-bit identifier (CMD_ID) in the 8 MSB, followed by a 16-bit data field in the LSB (CMD_DATA). The parity bit shall be set such that the sum of the number of set bits in the 24 command data bits plus the parity bit is odd. It is expected that instruments will reject commands with bad parity or framing (no stop bit), and will report an interface error in their telemetry stream (with the exception of MAG, due to the simplicity of its commanding needs and the fact that it is co-located in the IDPU). No commands retries will be attempted.

6. Telemetry Interface

Figure 3 shows the telemetry interface timing. **Note all signal polarities are as measured on the harness**

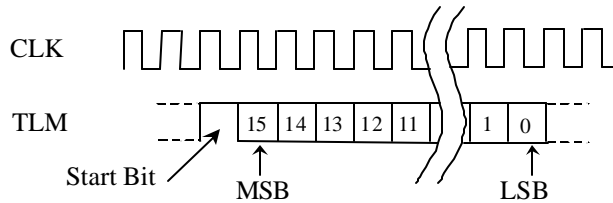

Figure 3 - Serial Telemetry Timing

6.1. Clock Edge

The instrument shall shift the next bit of the message out on the rising edge of CLK. The bit will be sampled by the IDPU on the next rising edge of CLK.

6.2. Synchronization

Messages are preceded by at least 17 bits of zero. The IDPU shall synchronize to the first non-zero bit as the START bit of the first word of the message. The end of message shall be indicated by a zero where the next start bit should be, followed by at least 16 more zeros. The number of zeros between messages shall be any number greater than or equal to 17. On reset, or in the event of a failure in the synchronization timing, the IDPU shall abort the message and ignore the data until at least 17 zeros in a row have been sent.

6.3. Data Stream Format

Messages shall consist of a block of one or more 16-bit words sent consecutively without gap, other than the START bit at the beginning of each word.

7. Command Message Coding

Command messages are somewhat different for the different instruments, as described below.

7.1. Sample Clock Message

This message is sent to all the instruments. The sample clock message is a special synchronous message used to synchronize the sample clocks of all the instruments. The CMD_ID of the message shall be hexadecimal code 0xF0, and the CMD_DATA shall be the sample clock. The message shall be sent once a second, every 1,000,000 cycles of CLK. The sample clock shall increment every second. The message is synchronized such that the rising edge of the clock between the Parity bit and the STOP bit corresponds to the exact second tick. The sample clock shall be in Hours:minutes:seconds format to match with the nominal integration times of:

1, 2, 10, 30 seconds

1, 5, 10, 15, 30, 60 minutes

The sample clock shall have a seconds counter, modulo 60, in the 6 LSB, a minutes counter, modulo 60, in the 6 middle bits, and an hour counter, modulo 16, in the 4 MSB.

7.2. **Spacecraft Clock Message**

SEP requires access to the spacecraft clock for time-stamping its telemetry packets. A message consisting of three commands will be sent once a second containing the UT time code provided by the spacecraft to the IDPU (see the IMPACT ICD). The time of transmission of this message will correspond to the UT indicated (perhaps with a fixed offset) to within a few milliseconds. SEP is responsible for interpolating this time code between messages using some kind of counter. The CMD_ID of these UT time commands shall be 0xF1, 0xF2, and 0xF3. The 16 MSB of the UT time code sent in the first word (CMD_ID = 0xF1), the middle 16 bits sent next (CMD_ID = 0xF2), and the 16 LSB of the UT time code sent last (CMD_ID = 0xF3). The 32MSB are units of seconds since some epoch, and the 16 LSB are binary fractions of seconds, in units of 2^{-16} seconds. The time corresponds to the time of the Sample Clock tic, and shall be sent shortly after the Sample Clock message.

7.3. **Reset Command**

This message may be sent to all instruments. It should be hardware-decoded by the SEP independent of the processor. It is used to reset the instrument (and SEP processor) back to its default configuration. It has CMD_ID = 0xFF, and CMD_DATA = **selectable from the ground**.

7.4. **SEP Command Packet Message**

SEP will receive multi-word CCSDS command packets. These will be passed on as received by the IDPU from the spacecraft (if the packet ApID indicates the command packet is for SEP), **without the CCSDS packet header**. The first word of the message shall have CMD_ID = 0x00. Subsequent words of the message shall have CMD_ID = 0x01. The command packet format has variable length, with the length included in the packet, so SEP should be able to determine when all of the command has been received. SEP should perform its own command verification, as needed, independent of the IDPU.

7.5. **MAG Command**

The MAG requires only one instrument-specific command, which shall have CMD_ID = 0. MAG will also receive the sample clock commands (CMD_ID=0xF0), but no others. The coding of bits in the MAG command is:

Bit 7 = Range

Bit 6 = IFC

Bit 5 = Cal

7.6. **SWEA/STE Commands**

The SWEA/STE commands are described in the SWEA/STE Interface FPGA (SIF) Description document.

7.7. **PLASTIC Commands**

PLASTIC Command codes are **TBD-PLASTIC**.

8. Telemetry Message Formats

Telemetry message formats are instrument specific. For all messages the first word, called the MESSAGE_ID shall indicate the type of message and its length (in words). The 10LSB of the MESSAGE_ID shall be the message length, and the 6MSB shall be a message type code. The message length shall be coded as the number of words in the message, including the MESSAGE_ID word, minus 2. The shortest possible message of two words shall have length code zero, while the longest possible message will consist of the MESSAGE_ID word plus 1024 data words, with a length code of 1023.

8.1. **SEP Messages**

SEP will provide 3 kinds of messages (lengths indicated exclude MESSAGE_ID word):

Telemetry Packets, Message Type = 0, Message length = 272 bytes

Sent no more often than once a second

Housekeeping blocks, Message Type = 1, Message length = 272 bytes

Sent no more often than once a second

Beacon blocks, Message Type = 2, Message Length = 144 bytes

Sent once a minute

The SEP telemetry packet rate shall be limited by the SEP instrument to its allocated bitrate. If too much SEP telemetry is sent and the telemetry packet queue is filled, telemetry packets will be lost. To avoid this, SEP must buffer up and meter out telemetry packets at close to its bitrate allocation. At no time should SEP send more than one packet a second, nor exceed its bitrate allocation by more than two packets over a 1-minute interval.

8.2. **MAG Messages**

Since the MAG has only one type of data, it will use no message ID field, but shall just send the 4 16-bit words corresponding to the measured value, 32 times a second.

8.3. **SWEA/STE Messages**

The SWEA/STE messages are described in the SWEA/STE Interface FPGA (SIF) Description document.

8.4. **PLASTIC Messages**

PLASTIC Messages are **TBD-PLASTIC**.