

STEREO *IMPACT*

Harness Specification

IMPACTHarnessSpec_K.doc
Version K – 2004-Jun-08

David Curtis, UCB IMPACT Project Manager

Document Revision Record

Rev.	Date	Description of Change	Approved By
A	2001-Mar-16	Preliminary Draft	-
B	2001-Mar-20	<ul style="list-style-type: none"> • Add harness responsibilities • Add details of spacecraft harness • Minor fixes 	-
C	2001-Aug-1	<ul style="list-style-type: none"> • Change power from TP to TSQ • Add BOOM temp sensor to BOOM-P2 • Split STE, SEPT-E, SIT 	-
D	2001-Sep-26	<ul style="list-style-type: none"> • Move SEPT and SIT actuator connector from SEP Central • Change IDPU-J2 to two twinax • Split STE into STE-U, STE-D • Add SEP mating connector info in sections 3.5 to 3.10 • Add SEP subsystem connector pinouts in sections 4.5.2 to 4.10.1 • Change SEP S/C thermal con. type/size 	-
E	2002-Nov-26	<ul style="list-style-type: none"> • Change to GSFC connector specifications for D connectors • Replace SWEA-J1 & -J3 with MDM connectors • Remove SWEA-J2 (internal) • Update SWEA connector pin-outs • Some connectors become internal (HET, LET, STE) • SEPT connectors combined at SEP end • Update SEPT connector pinouts. • Modify MAG connector pinouts 	-
F	2003-May-12	<ul style="list-style-type: none"> • Corrections to SEPT signal names • Add PLASTIC harness connector type & pinout • Update SIT Connector 	
G	2003-Sep-29	<ul style="list-style-type: none"> • PLASTIC Mating Connector P/N • Update spacecraft power harness wire size • Change SEPTE-J3 and SEPT-NS pinout • Add connector panel thickness • Add chassis ground to SIT-J3 	

H	2003-Oct-8	<ul style="list-style-type: none"> • Add harness shielding & termination details 	
I	2004-Mar-16	<ul style="list-style-type: none"> • Add Cover1 & Cover2 to IDPU to STE-U harness • Change coax to Gore • Add toroids to boom harness • Include BOOM-J3 pinout (to actuator) • Include Winchester connectors inside boom 	
J	2004-Mar-24	<ul style="list-style-type: none"> • Change type of Winchester connectors inside boom • Add STE-U temp sensor to STE-U pig-tail 	
K	2004-Jun-8	<ul style="list-style-type: none"> • Incorporate red-line corrections from flight boom assembly 	

Distribution List

Dave Curtis, UCB
 Peter Berg, UCB
 Jeremy McCauley, UCB
 Steve McBride, UCB
 David Myers, APL
 Mario Acuna, GSFC (MAG)
 Tycho von Rosenvinge, GSFC (SEP)
 Branislav Kecman, Caltech (SEP)
 Reinhold Mueller-Mellin, Kiel (SEPT)
 Ludovic Duvet, ESTEC (SEPT)
 Peter Walpole, UMd (SIT)
 Steven Turco, UNH (PLASTIC)
 Yvette Irwin, UCB

Table of Contents

Document Revision Record	i
Distribution List	ii
1. Introduction	1
1.1. <i>Document Conventions</i>	<i>1</i>
1.2. <i>Applicable Documents</i>	<i>1</i>
2. Harness Figures	1
3. Connector Types	4
3.1. <i>IDPU Connectors</i>	<i>4</i>
3.2. <i>Boom Connectors</i>	<i>4</i>
3.3. <i>SWEA Connectors</i>	<i>5</i>
3.4. <i>MAG Connector</i>	<i>5</i>
3.5. <i>SEP Connectors</i>	<i>5</i>
3.6. <i>SEPT-E Connectors</i>	<i>6</i>
3.7. <i>SEPT-NS Connectors</i>	<i>6</i>
3.8. <i>SIT Connectors</i>	<i>6</i>
3.9. <i>PLASTIC Connector (IDPU interface only)</i>	<i>6</i>
3.10. <i>Boom Internal Connectors</i>	<i>7</i>
4. Connector Pinouts	8
4.1. <i>IDPU Connectors</i>	<i>8</i>
4.1.1. IDPU-P1 (IDPU Power).....	8
4.1.2. IDPU-J2 (1553 Interface to Spacecraft).....	9
4.1.3. IDPU-P3 (IDPU to PLASTIC).....	9
4.1.4. IDPU-P4 (IDPU to SEP).....	10
4.1.5. IDPU-P5 (IDPU to SWEA/STE).....	10
4.1.6. IDPU-P6 (IDPU to MAG).....	11
4.1.7. IDPU-P7 (IDPU to STE-U).....	12
4.2. <i>Boom Connectors</i>	<i>13</i>
4.2.1. BOOM-P1 (SWEA/STE Power).....	13
4.2.2. BOOM-P2 (SWEA S/C Temp Sensor).....	13
4.2.3. BOOM-P3 (Boom Actuator Power).....	14
4.2.4. BOOM-P4 (SWEA/STE to IDPU).....	14
4.2.5. BOOM-P5 (IDPU to MAG).....	15
4.2.6. BOOM-P6 (IDPU to STE-U).....	16
4.3. <i>Internal Boom Harness</i>	<i>17</i>
4.3.1. BOOM-J1 (SWEA/STE Power).....	17
4.3.1.1 BOOM-X1 (Boom Deployment Heater / Temp Sensor).....	17
4.3.1.2 BOOM-Y1 (Boom Deployment Heater / Temp Sensor).....	17
4.3.2. BOOM-J2 (SWEA S/C Temp Sensor).....	18
4.3.3. BOOM-J3 (Boom Actuator Power).....	18
4.3.3.1 BOOM-X3 (Boom Actuator).....	18
4.3.3.2 BOOM-Y3 (Boom Actuator).....	18
4.3.4. BOOM-J4 (SWEA/STE to IDPU).....	19
4.3.5. BOOM-J5 (IDPU to MAG).....	19
4.3.6. BOOM-J6 (IDPU to STE-U).....	20
4.3.6.1 BOOM-X6 (STE-U).....	21

4.3.6.2	STE-U P1 (STE-U pig-tail)	22
4.3.7.	SWEA-P1 (IDPU to SWEA)	23
4.3.8.	MAG-J1 (IDPU to MAG)	24
4.4.	SWEA Connectors	25
4.4.1.	SWEA-P1 (IDPU to SWEA)	25
4.4.2.	SWEA-P3 (HV/Actuator Enable)	25
4.5.	SEP Connectors	26
4.5.1.	SEP-P1 (SEP Power)	26
4.5.2.	SEP-P2 (SEP S/C Temp. Sensors)	26
4.5.3.	SEP-P3 (SIT & SEPT Cover Actuators)	27
4.5.4.	SEP-P4 (SEP to IDPU)	27
4.5.5.	SEP-P5 (SEP to SIT)	28
4.5.6.	SEP-P6 (SEP to SEPT-NS)	30
4.5.7.	SEP-P7 (SEP to SEPT-NS)	30
4.5.8.	SEP-P8 (SEP to SEPT-E)	31
4.5.9.	SEP-P9 (SEP to SEPT-E)	31
4.6.	SEPT-E Connectors	32
4.6.1.	SEPTE-P1 (SEP to SEPT-E)	32
4.6.2.	SEPTE-P2 (SEP to SEPT-E)	32
4.6.3.	SEPTE-P3 (S/C to SEPT-E)	33
4.7.	SEPT-NS Connectors	34
4.7.1.	SEPTNS-P1 (SEP to SEPT-NS)	34
4.7.2.	SEPTNS-P2 (SEP to SEPT-NS)	34
4.7.3.	SEPTNS-P3 (S/C to SEPT-NS)	35
4.8.	SIT Connectors	36
4.8.1.	SIT-P1 (SEP to SIT)	36
4.8.2.	SIT-P2 (SIT HV Disable/Test)	37
4.8.3.	SIT-P3 (S/C to SIT)	37
4.9.	PLASTIC Connectors	38
4.9.1.	PLA-J4 (IDPU to PLASTIC)	38
5.	Harness Shielding and Termination	39
5.1.	UCB Harnesses	39
5.2.	Caltech Harnesses	41
6.	Harness Responsibilities	44

1. Introduction

This specification describes the harnesses between the various parts of the IMPACT instrument suite, as well as the interface connectors to the spacecraft. The spec covers the connector types and pinouts as well as the harness wiring details.

1.1. *Document Conventions*

In this document, **TBD** (To Be Determined) means that no data currently exists. A value followed by **TBR** (To Be Resolved) means that this value is preliminary. In either case, the value is typically followed by a code such as UCB indicating who is responsible for providing the data, and a unique reference number.

1.2. *Applicable Documents*

The following documents include drawings and STEREO Project policies. All documents and drawings can be found on the Berkeley STEREO/IMPACT FTP site:

<http://sprg.ssl.berkeley.edu/impact/dwc/>

1. IMPACT/Spacecraft ICD (on APL web site)
2. ICD/Impact Serial Interface
3. Project/EMC_7381-9030 STEREO EMC Requirements
4. Project/ContaminationControlPlan_7381-9006.pdf

2. Harness Figures

Figure 2-1 is a schematic of the STEREO IMPACT harness indicating the connector designations, where they are, and what they connect to. Figure 2-2 shows the SEP harnessing, showing some internal details.

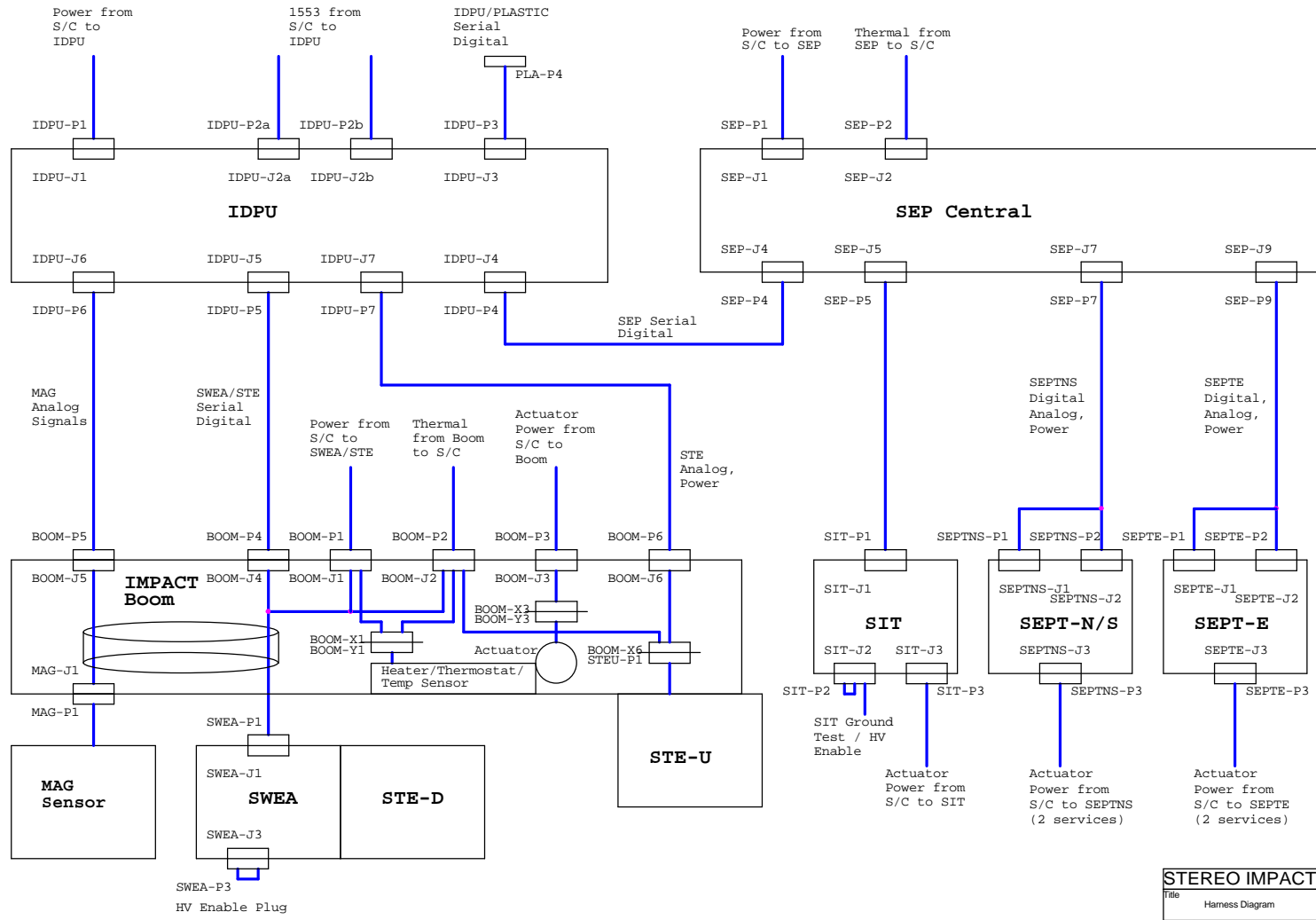

STEREO IMPACT		University of California Space Science Lab
Title: Harness Diagram		
Size: B	Document Number: IMPACT_HARNESS	Rev: F
Date: Thursday, October 31, 2002	Sheet: 1	of: 1

Figure 2-1 - IMPACT Harness Schematic

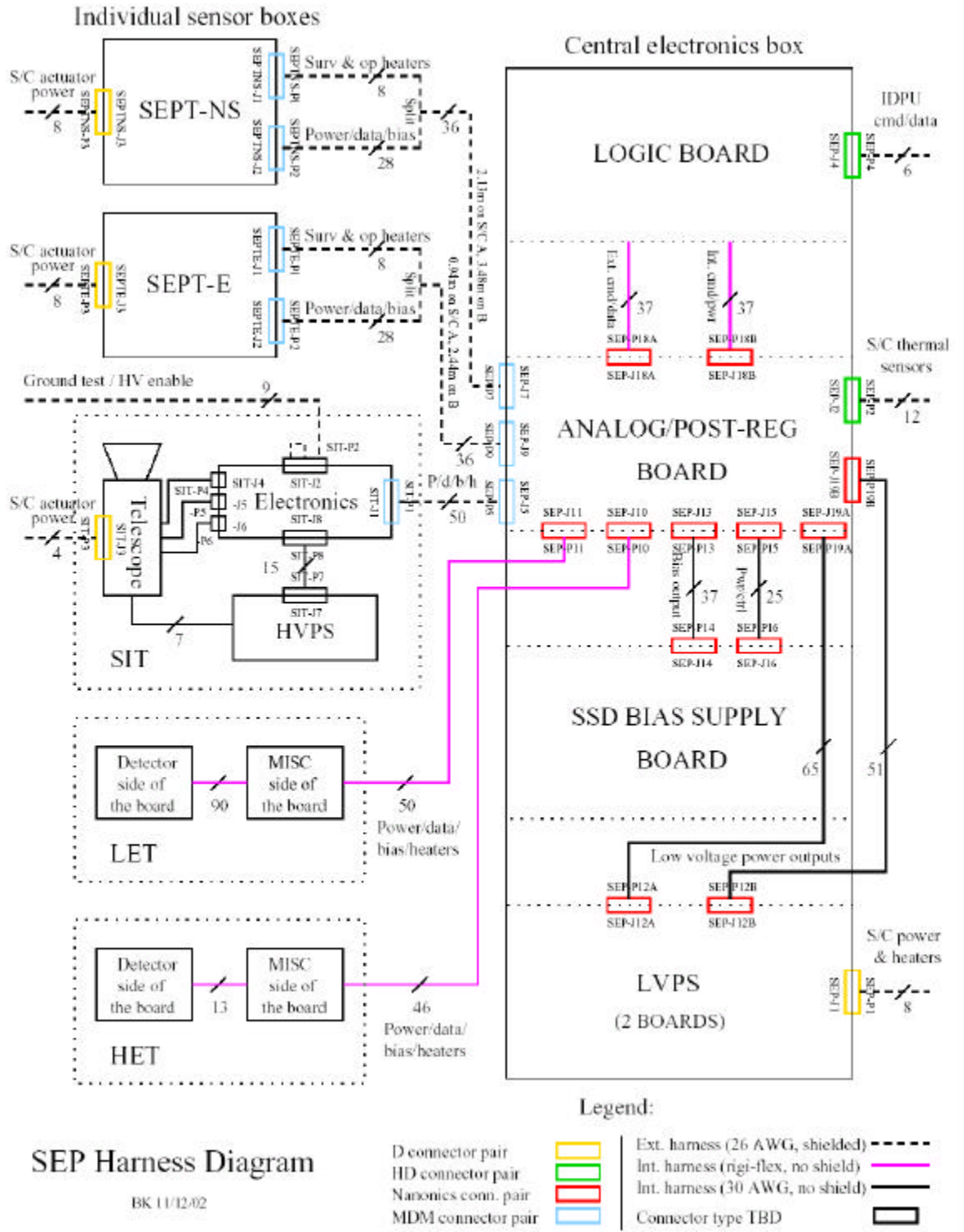

Figure 2-2 SEP Harness

3. Connector Types

The instrument harness connectors are described below. "D" connectors are standard density, "HD" are High Density D-type Connectors. "MDM" are MDM D connectors. Note that these are the HARNESS connectors, not the box connectors. Harness connectors are designated by the box they attach to (such as IPC), followed by -Pn (where n is the connector number on that box), while box connectors designators are identical except they are followed by -Jn.

3.1. IDPU Connectors

Name	Use	Type	Part Number	Mating Connector	Con. Mount
IDPU -P1	IDPU Power from Spacecraft	D15S	GSFC 311P409-2S-B-15	GSFC 311P409-2P-B-12	Front
IDPU -P2a	1553 A Interface from Spacecraft	Twinax	Sabritec 015028-2000	Sabritec 015100-5001	Front
IDPU -P2b	1553 B Interface from Spacecraft	Twinax	Sabritec 015028-2000	Sabritec 015100-5001	Front
IDPU -P3	IDPU to PLASTIC Interface	HD15S	GSFC 311P407-1S-B-12	GSFC 311P407-1P-B-12	Front
IDPU -P4	IDPU to SEP Interface	HD15S	GSFC 311P407-1S-B-12	GSFC 311P407-1P-B-12	Front
IDPU -P5	IDPU to SWEA/STE Interface	HD15S	GSFC 311P407-1S-B-12	GSFC 311P407-1P-B-12	Front
IDPU -P6	IDPU to MAG Interface	HD15P	GSFC 311P407-1P-B-12	TBD-MAG-001	Front
IDPU -P7	IDPU to STE-U Interface	HD26P	GSFC 311P407-2P-B-12	GSFC 311P407-2S-B-12	Front

3.2. Boom Connectors

Name	Use	Type	Part Number	Mating Connector	Con. Mount
BOOM -P1	SWEA/STE Power from Spacecraft	D15S	GSFC 311P409-2S-B-15	GSFC 311P409-2P-B-12	Rear 1.6mm
BOOM -P2	Temp Sensor Interface to Spacecraft	D9P	GSFC 311P409-1P-B-15	GSFC 311P409-1S-B-12	Rear 1.6mm
BOOM -P3	Boom Actuator Power from Spacecraft	D9S	GSFC 311P409-1S-B-15	GSFC 311P409-1P-B-12	Rear 1.6mm
BOOM -P4	IDPU to SWEA/STE Interface	HD15P	GSFC 311P407-1P-B-12	GSFC 311P407-1S-B-12	Rear 1.6mm
BOOM -P5	IDPU to MAG Interface	HD15S	GSFC 311P407-1S-B-12	GSFC 311P407-1P-B-12	Rear 1.6mm
BOOM -P6	IDPU to STE-U Interface	HD26S	GSFC 311P407-2S-B-12	GSFC 311P407-2P-B-12	Rear 1.6mm

3.3. SWEA Connectors

Name	Use	Type	Part Number	Mating Connector
SWEA-P1	SWEA/STE Interface (Signal+Power+Temp)	MDM15R	M83513/04-B11N	Airborn MK-232-015-125-2200
SWEA-P3	Enable Plug	MDM15R	M83513/04-B11N	M83513/04-B1NP

3.4. MAG Connector

Name	Use	Type	Part Number	Mating Connector
MAG-P1	MAG Sensor Pigtail Connector	HD15P	TBD-MAG001	GSFC 311P407-1S-B-12

3.5. SEP Connectors

Name	Use	Type	Part Number	Mating Connector	Con. Mount
SEP-P1	SEP Power from Spacecraft	D15S	GSFC 311P409-2S-B-15	GSFC 311P409-2P-B-12	Rear, 1.5mm
SEP-P2	SEP Temp Sensor Interface to Spacecraft	HD15S	GSFC 311P407-1S-B-15	GSFC 311P407-1P-B-12	Rear, 1.5mm
SEP-P4	IDPU to SEP Interface	HD15P	M24308/7-373	GSFC 311P407-1S-B-12	Rear, 1.5mm
SEP-P5	SEP to SIT Interface	MDM51S	MWDM2L-51S- 6J5-7M-429A	MWDM2L- 51PCBRP-.110- 429A	Rear, 1.5mm
SEP-P7	SEP to SEPT-NS Dig/Ana/Pwr Interface	MDM37S	MWDM2L-37S- 6J5-xxM-429A	MWDM2L- 37PCBRP-.110- 429A	Rear, 1.5mm
SEP-P9	SEP to SEPT-E Dig/Ana/Pwr Interface	MDM37S	MWDM2L-37S- 6J5-xxM-429A	MWDM2L- 37PCBRP-.110- 429A	Rear, 1.5mm

3.6. SEPT-E Connectors

Name	Use	Type	Part Number	Mating Connector	Con. Mount
SEPTE-P1	SEP to SEPT-E Heater Interface	MDM9P	MWDM2L-9P-6J5-12M-429A	MWDM2L-9S-6J5-12M-429A	Rear, 1.0mm
SEPTE-P2	SEP to SEPT-E Dig/Ana/Pwr Interface	MDM31P	MWDM2L-31P-6J5-12M-429A	MWDM2L-31SCBRP-.110-429A	Rear, 1.0mm
SEPTE-P3	Spacecraft to SEPT-E Actuator Power	D9S	GSFC 311P409-1S-B-15	GSFC 311P409-1P-B-12	Rear, 1.0mm

3.7. SEPT-NS Connectors

Name	Use	Type	Part Number	Mating Connector	Con. Mount
SEPTNS-P1	SEP to SEPT-NS Heater Interface	MDM9P	MWDM2L-9P-6J5-12M-429A	MWDM2L-9S-6J5-12M-429A	Rear, 1.0mm
SEPTNS-P2	SEP to SEPT-NS Dig/Ana/Pwr Interface	MDM31P	MWDM2L-31P-6J5-12M-429A	MWDM2L-31SCBRP-.110-429A	Rear, 1.0mm
SEPTNS-P3	Spacecraft to SEPT-NS Actuator Power	D9S	GSFC 311P409-1S-B-15	GSFC 311P409-1P-B-12	Rear, 1.0mm

3.8. SIT Connectors

Name	Use	Type	Part Number	Mating Connector	Con. Mount
SIT-P1	SEP to SIT Interface	MDM51P	MWDM2L-51P-6J5-12M-429A	MWDM2L-51SCBRP-.110-429A	Rear, 1.5mm
SIT-P2	SIT HV Disable Plug / Test Interface	TBD-SIT-002	TBD-SEP-001	TBD-SEP-001	Rear, 1.5mm
SIT-P3	Spacecraft to SIT Actuator Power	D9S	GSFC 311P409-1S-B-15	GSFC 311P409-1P-B-12	Rear, 1.5mm

3.9. PLASTIC Connector (IDPU interface only)

Name	Use	Type	Part Number	Mating Connector	Con. Mount
PLA-P4	IDPU to PLASTIC interface	D25P	GSFC 311P409-3P-B-12	GSFC 311P409-3S-B-12	Rear, 0.075"

3.10. Boom Internal Connectors

Name	Use	Type	Part Number
BOOM-X1	Spacecraft end of break in Heater/Temp Sensor circuit	Winchester	JF3S1PBCD
BOOM-Y1	Heater end of break in Heater/Temp Sensor circuit	Winchester	JF1S3PC
BOOM-X3	Spacecraft end of break in Actuator Primary	Winchester	JF2S2PCD
BOOM-Y3	Actuator end of break in Actuator Primary	Winchester	JF2S2PCD
BOOM-X6	IDPU end of break in STE-U harness	HD26S	GSFC 311P407-2S-B-12
STEU-P1	STE-U end of break in STE-U harness	HD26P	GSFC 311P407-2P-B-12

4. Connector Pinouts

In the following tables:

- TSPN is a twisted-shielded pair with shield not connected (at this end).
- TSPS is a twisted shielded pair with shield terminated on the connector backshell.
- TSP is a twisted shielded pair with the shield connected to a pin.
- TP is a twisted pair, no shield or jacket (just two wires twisted together).
- TT is a twisted triple
- T5 is a twisted 5-wire group
- TSQ is a twisted shielded quad (shield terminated at backshell)
- Coax is an Gore CXN3277 low-magnetic coax (similar to RG178)
- TA is 77 ohm twinax used for the 1553 harness, type M17/176-00002

All harnesses will have a common over-shield connected to chassis ground at both ends via the connector shell and mounting hardware except where otherwise noted. Chassis ground pin on connectors is normally not connected in the harness.

4.1. IDPU Connectors

4.1.1. IDPU-P1 (IDPU Power)

Pin	Signal	Destination	Harness
1	Spare		
2	+28V Primary	Spacecraft	#26 TSQ w/3,10,11
3	+28V Redundant	Spacecraft	#26 TSQ w/2,10,11
4	Spare		
5	+28V Heater Primary	Spacecraft	#26 TSQ w/6,13,14
6	+28V Heater Redundant	Spacecraft	#26 TSQ w/5,13,14
7	Spare		
8	Chassis (connected in IDPU to IDPU chassis)		
9	Spare		
10	+28V Return Primary	Spacecraft	#26 TSQ w/2,3,11
11	+28V Return Redundant	Spacecraft	#26 TSQ w/2,3,10
12	Spare		
13	+28V Heater Return Primary	Spacecraft	#26 TSQ w/5,6,14
14	+28V Heater Return Redundant	Spacecraft	#26 TSQ w/5,6,13
15	Spare		

4.1.2. IDPU-J2 (1553 Interface to Spacecraft)

IDPU-J2a

Pin	Signal	Destination	Harness
1	1553_A_P	Spacecraft	TA-blue
2	1553_A_N (Inner shield)	Spacecraft	TA-white
3	Outer Shield	Spacecraft	TA-Shield

IDPU-J2b

Pin	Signal	Destination	Harness
1	1553_B_P	Spacecraft	TA-blue
2	1553_B_N (Inner shield)	Spacecraft	TA-white
3	Outer Shield	Spacecraft	TA-Shield

4.1.3. IDPU-P3 (IDPU to PLASTIC)

Pin	Signal	Destination	Harness
1	CLK	PLA-P4 pin 1	Coax w/2
2	CLK-RET	PLA-P4 pin 2	Coax Shield w/1
3	Spare		
4	Spare		
5	Spare		
6	CMD	PLA-P4 pin 6	Coax w/7
7	CMD-RET	PLA-P4 pin 7	Coax Shield w/6
8	Spare		
9	Spare		
10	Spare		
11	TLM	PLA-P4 pin 11	Coax w/12
12	TLM-RET	PLA-P4 pin 12	Coax Shield w/11
13	Spare		
14	Spare		
15	Chassis (connected in IDPU to IDPU chassis)		

4.1.4. IDPU-P4 (IDPU to SEP)

Pin	Signal	Destination	Harness
1	CLK	SEP-P4 pin 1	Coax w/2
2	CLK-RET	SEP-P4 pin 2	Coax Shield w/1
3	Spare		
4	Spare		
5	Spare		
6	CMD	SEP-P4 pin 6	Coax w/7
7	CMD-RET	SEP-P4 pin 7	Coax Shield w/6
8	Spare		
9	Spare		
10	Spare		
11	TLM	SEP-P4 pin 11	Coax w/12
12	TLM-RET	SEP-P4 pin 12	Coax Shield w/11
13	Spare		
14	Spare		
15	Chassis (connected in IDPU to IDPU chassis)		

(Note: This is a 1:1 harness)

4.1.5. IDPU-P5 (IDPU to SWEA/STE)

Pin	Signal	Destination	Harness
1	CLK	BOOM-P4 pin 1	Coax w/2
2	CLK-RET	BOOM-P4 pin 2	Coax Shield w/1
3	Spare		
4	Spare		
5	Spare		
6	CMD	BOOM-P4 pin 6	Coax w/7
7	CMD-RET	BOOM-P4 pin 7	Coax Shield w/6
8	Spare		
9	Spare		
10	Spare		
11	TLM	BOOM-P4 pin 11	Coax w/12
12	TLM-RET	BOOM-P4 pin 12	Coax Shield w/11
13	Spare		
14	Spare		
15	Chassis (connected in IDPU to IDPU chassis)		

(Note: This is a 1:1 harness)

4.1.6. IDPU-P6 (IDPU to MAG)

Pin	Signal	Destination	Harness
1	XYZ Drive	BOOM-P5 pin 1	Coax w/9
2	X Sensor Sig	BOOM-P5 pin 2	Coax w/10
3	Y Sensor Sig	BOOM-P5 pin 3	Coax w/11
4	Z Sensor Sig	BOOM-P5 pin 4	Coax w/12
5	MAG Temp Sensor	BOOM-P5 pin 5	#26 TSP w/13,14
6	MAG Heater	BOOM-P5 pin 6	#26 TSP w/7,8
7	MAG Heater RET	BOOM-P5 pin 7	#26 TSP w/6,8
8	MAG Heater Shield	BOOM-P5 pin 8	#26 TSP Shield
9	XYZ Drive RET, T2 Ret	BOOM-P5 pin 9	Coax Shield w/1
10	X Sensor Sig RET	BOOM-P5 pin 10	Coax Shield w/2
11	Y Sensor Sig RET	BOOM-P5 pin 11	Coax Shield w/3
12	Z Sensor Sig RET	BOOM-P5 pin 12	Coax Shield w/4
13	MAG Temp Sensor RET	BOOM-P5 pin 13	#26 TSP w/5,14
14	MAG Temp Sensor Shield, T2	BOOM-P5 pin 14	#26 TSP Shield
15	Chassis (connected in IDPU to IDPU chassis)		

(Note: This is a 1:1 harness)

4.1.7. IDPU-P7 (IDPU to STE-U)

Pin	Signal	Destination	Harness
1	OUTPUT1	BOOM-P6 pin 1	Coax w/2
2	OUTPUT RET	BOOM-P6 pin 2	Coax Shield w/1
3	OUTPUT2	BOOM-P6 pin 3	Coax w/4
4	OUTPUT RET	BOOM-P6 pin 4	Coax Shield w/3
5	OUTPUT3	BOOM-P6 pin 5	Coax w/6
6	OUTPUT RET	BOOM-P6 pin 6	Coax Shield w/5
7	OUTPUT4	BOOM-P6 pin 7	Coax w/8
8	OUTPUT RET	BOOM-P6 pin 8	Coax Shield w/7
9	Spare		
10	Test RET	BOOM-P6 pin 10	Coax Shield w/11
11	Test	BOOM-P6 pin 11	Coax w/10
12	Ground	BOOM-P6 pin 12	#26 TT w/13,14
13	+5V	BOOM-P6 pin 13	#26 TT w/12,14
14	-5V	BOOM-P6 pin 14	#26 TT w/12,13
15	Bias	BOOM-P6 pin 15	#26
16	-12V	BOOM-P6 pin 16	#26
17	Cover2	BOOM-P6 pin 17	#26
18	Cover1	BOOM-P6 pin 18	#26
19	Door Close Act.	BOOM-P6 pin 19	#26 TT w/20,21
20	Door Open Act.	BOOM-P6 pin 20	#26 TT w/19,21
21	Door Act. RET	BOOM-P6 pin 21	#26 TT w/19,20
22	Spare		
23	Spare		
24	STE Temp	BOOM-P6 pin 24	#26 TP w/25
25	STE Temp RET	BOOM-P6 pin 25	#26 TP w/24
26	Chassis (connected in IDPU to IDPU chassis)		

(Note: This is a 1:1 harness)

4.2. Boom Connectors

4.2.1. BOOM-P1 (SWEA/STE Power)

Pin	Signal	Destination	Harness
1	Spare		
2	+28V Primary	Spacecraft	#26 TSQ w/3,10,11
3	+28V Redundant	Spacecraft	#26 TSQ w/2,10,11
4	+28V Boom Deployment Heater Primary	Spacecraft	#22 TSQ w/7,12,15
5	+28V Heater Primary	Spacecraft	#26 TSQ w/6,13,14
6	+28V Heater Redundant	Spacecraft	#26 TSQ w/5,13,14
7	+28V Boom Deployment Heater Redundant	Spacecraft	#22 TSQ w/4,12,15
8	Chassis (connected in BOOM to BOOM chassis)		
9	Spare		
10	+28V Return Primary	Spacecraft	#26 TSQ w/2,3,11
11	+28V Return Redundant	Spacecraft	#26 TSQ w/2,3,10
12	+28V Boom Deployment Heater Return Primary	Spacecraft	#22 TSQ w/4,7,15
13	+28V Heater Return Primary	Spacecraft	#26 TSQ w/5,6,14
14	+28V Heater Return Redundant	Spacecraft	#26 TSQ w/5,6,13
15	+28V Boom Deployment Heater Return Redundant	Spacecraft	#22 TSQ w/4,7,12

4.2.2. BOOM-P2 (SWEA S/C Temp Sensor)

Pin	Signal	Destination	Harness
1	SWEA Temp Sensor	Spacecraft	#24 TP w/6
2	BOOM Temp Sensor	Spacecraft	#24 TP w/7
3	STE-U Temp Sensor	Spacecraft	#24 TP w/8
4	Spare		
5	Spare		
6	SWEA Temp Sensor RET	Spacecraft	#24 TP w/1
7	BOOM Temp Sensor RET	Spacecraft	#24 TP w/2
8	STE-U Temp Sensor RET	Spacecraft	#24 TP w/3
9	Chassis (connected in BOOM to BOOM chassis)		

4.2.3. BOOM-P3 (Boom Actuator Power)

Pin	Signal	Destination	Harness
1	BOOM Release	Spacecraft	#22 TSP w/6
2	BOOM Release	Spacecraft	#22 TSP w/7
3	Spare		
4	Spare		
5	Spare		
6	BOOM Release RET	Spacecraft	#22 TSP w/1
7	BOOM Release RET	Spacecraft	#22 TSP w/2
8	Spare		
9	Shield Ground (Connected in BOOM to BOOM chassis)		

4.2.4. BOOM-P4 (SWEA/STE to IDPU)

Pin	Signal	Destination	Harness
1	CLK	IDPU-P5 pin 1	Coax w/2
2	CLK-RET	IDPU-P5 pin 2	Coax Shield w/1
3	Spare		
4	Spare		
5	Spare		
6	CMD	IDPU-P5 pin 6	Coax w/7
7	CMD-RET	IDPU-P5 pin 7	Coax Shield w/6
8	Spare		
9	Spare		
10	Spare		
11	TLM	IDPU-P5 pin 11	Coax w/12
12	TLM-RET	IDPU-P5 pin 12	Coax Shield w/11
13	Spare		
14	Spare		
15	Chassis (connected in BOOM to BOOM chassis)		

(Note: This is a 1:1 harness)

4.2.5. BOOM-P5 (IDPU to MAG)

Pin	Signal	Destination	Harness
1	XYZ Drive	IDPU-P6 pin 1	Coax w/9
2	X Sensor Sig	IDPU-P6 pin 2	Coax w/10
3	Y Sensor Sig	IDPU-P6 pin 3	Coax w/11
4	Z Sensor Sig	IDPU-P6 pin 4	Coax w/12
5	MAG Temp Sensor	IDPU-P6 pin 5	#26 TSP w/13,14
6	MAG Heater	IDPU-P6 pin 6	#26 TSP w/7,8
7	MAG Heater RET	IDPU-P6 pin 7	#26 TSP w/6,8
8	MAG Heater Shield	IDPU-P6 pin 8	#26 TSP Shield
9	XYZ Drive RET, T2 Ret	IDPU-P6 pin 9	Coax Shield w/1
10	X Sensor Sig RET	IDPU-P6 pin 10	Coax Shield w/2
11	Y Sensor Sig RET	IDPU-P6 pin 11	Coax Shield w/3
12	Z Sensor Sig RET	IDPU-P6 pin 12	Coax Shield w/4
13	MAG Temp Sensor RET	IDPU-P6 pin 13	#26 TSP w/5,14
14	MAG Temp Sensor Shield, T2	IDPU-P6 pin 14	#26 TSP Shield
15	Chassis (connected in BOOM to BOOM chassis)		

(Note: This is a 1:1 harness)

4.2.6. BOOM-P6 (IDPU to STE-U)

Pin	Signal	Destination	Harness
1	OUTPUT1	IDPU-P7 pin 1	Coax w/2
2	OUTPUT RET	IDPU-P7 pin 2	Coax Shield w/1
3	OUTPUT2	IDPU-P7 pin 3	Coax w/4
4	OUTPUT RET	IDPU-P7 pin 4	Coax Shield w/3
5	OUTPUT3	IDPU-P7 pin 5	Coax w/6
6	OUTPUT RET	IDPU-P7 pin 6	Coax Shield w/5
7	OUTPUT4	IDPU-P7 pin 7	Coax w/8
8	OUTPUT RET	IDPU-P7 pin 8	Coax Shield w/7
9	Spare		
10	Test RET	IDPU-P7 pin 10	Coax Shield w/11
11	Test	IDPU-P7 pin 11	Coax w/10
12	Ground	IDPU-P7 pin 12	#26 TT w/13,14
13	+5V	IDPU-P7 pin 13	#26 TT w/12,14
14	-5V	IDPU-P7 pin 14	#26 TT w/12,13
15	Bias	IDPU-P7 pin 15	#26
16	-12V	IDPU-P7 pin 16	#26
17	Cover2	IDPU-P7 pin 17	#26
18	Cover1	IDPU-P7 pin 18	#26
19	Door Close Act.	IDPU-P7 pin 19	#26 TT w/20,21
20	Door Open Act.	IDPU-P7 pin 20	#26 TT w/19,21
21	Door Act. RET	IDPU-P7 pin 21	#26 TT w/19,20
22	Spare		
23	Spare		
24	STE Temp	IDPU-P7 pin 24	#26 TP w/25
25	STE Temp RET	IDPU-P7 pin 25	#26 TP w/24
26	Chassis (connected in IDPU to IDPU chassis)		

(Note: This is a 1:1 harness)

4.3. Internal Boom Harness

4.3.1. BOOM-J1 (SWEA/STE Power)

Pin	Signal	Destination	Harness
1	Spare		
2	+28V Primary	SWEA-P1 pin 8	#26 TSP w/10
3	+28V Redundant	SWEA-P1 pin 8	#26 TSP w/11
4	+28V Boom Deployment Heater Primary	BOOM-X1 pin A	#22 TP w/12
5	+28V Heater Primary	SWEA-P1 pin 7	#26 TSP w/13
6	+28V Heater Redundant	SWEA-P1 pin 7	#26 TSP w/14
7	+28V Boom Deployment Heater Redundant	BOOM-X1 pin A	#22 TP w/15
8	Chassis (connected in BOOM to BOOM chassis)		
9	Spare		
10	+28V Return Primary	SWEA-P1 pin 14	#26 TSP w/2
11	+28V Return Redundant	SWEA-P1 pin 14	#26 TSP w/3
12	+28V Boom Deployment Heater Return Primary	BOOM-X1 pin C	#22 TP w/4
13	+28V Heater Return Primary	SWEA-P1 pin 15	#26 TSP w/5
14	+28V Heater Return Redundant	SWEA-P1 pin 15	#26 TSP w/6
15	+28V Boom Deployment Heater Return Redundant	BOOM-X1 pin C	#22 TP w/7

Note primary and redundant power connected at BOOM-J1, with a single TP up the boom and heater. Terminate internal shields on TSP to chassis/backshell.

Add 6 turns of all wires except deployment heater wires to the BOOM-J1 connector around a F42206 toroid close to the BOOM-J1 connector

4.3.1.1 BOOM-X1 (Boom Deployment Heater / Temp Sensor)

Pin	Signal	Destination	Harness
A (s)	BOOM Heater.	BOOM-J1 pin 4,7	#22 TP w/C
B (p)	BOOM Temp Sensor RET	BOOM-J2 pin 7	#26 TP w/D
C (s)	BOOM Heater RET	BOOM-J1 pin 12,15	#22 TP w/A
D (s)	BOOM Temp Sensor	BOOM-J2 pin 2	#26 TP w/B

4.3.1.2 BOOM-Y1 (Boom Deployment Heater / Temp Sensor)

Pin	Signal	Destination	Harness
A (p)	BOOM Heater.	Heater	#22 TP w/C
B (s)	BOOM Temp Sensor RET	Boom Temp Sensor	#26 TP w/D
C (p)	BOOM Heater RET	Thermostat	#22 TP w/A
D (p)	BOOM Temp Sensor	Boom Temp Sensor	#26 TP w/B

Boom deployment heater/thermostat connected in series

4.3.2. BOOM-J2 (SWEA S/C Temp Sensor)

Pin	Signal	Destination	Harness
1	SWEA Temp Sensor	SWEA-P1 pin 4	#26 TSP w/6
2	BOOM Temp Sensor	BOOM-X1 pin D	#26 TP w/7
3	STE-U Temp Sensor	BOOM-X6 pin 22	#26 TP w/8
4	Spare		
5	Spare		
6	SWEA Temp Sensor RET	SWEA-P1 pin 5	#26 TSP w/1
7	BOOM Temp Sensor RET	BOOM-X1 pin B	#26 TP w/2
8	STE-U Temp Sensor	BOOM-X6 pin 23	#26 TP w/3
9	Chassis (connected in BOOM to BOOM chassis)	Boom Chassis	

Terminate internal shield on TSP to chassis/backshell

4.3.3. BOOM-J3 (Boom Actuator Power)

Pin	Signal	Destination	Harness
1	BOOM Release Pri.	BOOM-X3 pin A	#22 TP w/6
2	BOOM Release Sec.	BOOM-X3 pin B	#22 TP w/7
3	Spare		
4	Spare		
5	Spare		
6	BOOM Release Pri. RET	BOOM-X3 pin C	#22 TP w/1
7	BOOM Release Sec. RET	BOOM-X3 pin D	#22 TP w/2
8	Spare		
9	Shield Ground (Connected in BOOM to BOOM chassis)		

4.3.3.1 BOOM-X3 (Boom Actuator)

Pin	Signal	Destination	Harness
A (s)	BOOM Release Pri.	BOOM-J3 pin 1	#22 TP w/C
B (s)	BOOM Release Sec.	BOOM-J3 pin 2	#22 TP w/D
C (p)	BOOM Release Pri. RET	BOOM-J3 pin 6	#22 TP w/A
D (p)	BOOM Release Sec. RET	BOOM-J3 pin 7	#22 TP w/B

4.3.3.2 BOOM-Y3 (Boom Actuator)

Pin	Signal	Destination	Harness
D (p)	BOOM Release Pri.	Act. PRI (White)	#22 TP w/B
C (p)	BOOM Release Sec.	Act. SEC (White/Orange)	#22 TP w/A
B (s)	BOOM Release Pri. RET	Act. PRI RET (White/Blue)	#22 TP w/D
A (s)	BOOM Release Sec. RET	Act. SEC RET (White/Green)	#22 TP w/C

4.3.4. BOOM-J4 (SWEA/STE to IDPU)

Pin	Signal	Destination	Harness
1	CLK	SWEA-P1 pin 11	Coax w/2
2	CLK-RET	SWEA-P1 pin 6	Coax Shield w/1
3	Spare		
4	Spare		
5	Spare		
6	CMD	SWEA-P1 pin 10	Coax w/7
7	CMD-RET	SWEA-P1 pin 4	Coax Shield w/6
8	Spare		
9	Spare		
10	Spare		
11	TLM	SWEA-P1 pin 9	Coax w/12
12	TLM-RET	SWEA-P1 pin 2	Coax Shield w/11
13	Spare		
14	Spare		
15	Chassis (connected in BOOM to BOOM chassis)		

(Note: This is a 1:1 harness)

Add 6 turns of all wires to the BOOM-J4 connector around a F42206 toroid close to the BOOM-J4 connector

4.3.5. BOOM-J5 (IDPU to MAG)

Pin	Signal	Destination	Harness
1	XYZ Drive	MAG-J1 pin 1	Coax w/9
2	X Sensor Sig	MAG-J1 pin 2	Coax w/10
3	Y Sensor Sig	MAG-J1 pin 3	Coax w/11
4	Z Sensor Sig	MAG-J1 pin 4	Coax w/12
5	MAG Temp Sensor	MAG-J1 pin 5	#26 TSP w/13,14
6	MAG Heater	MAG-J1 pin 6	#26 TSP w/7,8
7	MAG Heater RET	MAG-J1 pin 7	#26 TSP w/6,8
8	MAG Heater Shield	MAG-J1 pin 8	#26 TSP Shield
9	XYZ Drive RET, T2 Ret	MAG-J1 pin 9	Coax Shield w/1
10	X Sensor Sig RET	MAG-J1 pin 10	Coax Shield w/2
11	Y Sensor Sig RET	MAG-J1 pin 11	Coax Shield w/3
12	Z Sensor Sig RET	MAG-J1 pin 12	Coax Shield w/4
13	MAG Temp Sensor RET	MAG-J1 pin 13	#26 TSP w/5,14
14	MAG Temp Sensor Shield, T2	MAG-J1 pin 14	#26 TSP Shield
15	Chassis (connected in BOOM to BOOM chassis)		

(Note: This is a 1:1 harness)

Add 6 turns of all wires to the BOOM-J5 connector around a F42206 toroid close to the BOOM-J5 connector

4.3.6. BOOM-J6 (IDPU to STE-U)

Pin	Signal	Destination	Harness
1	OUTPUT1	BOOM-X6 pin 1	Coax w/2
2	OUTPUT RET	BOOM-X6 pin 2	Coax Shield w/1
3	OUTPUT2	BOOM-X6 pin 3	Coax w/4
4	OUTPUT RET	BOOM-X6 pin 4	Coax Shield w/3
5	OUTPUT3	BOOM-X6 pin 5	Coax w/6
6	OUTPUT RET	BOOM-X6 pin 6	Coax Shield w/5
7	OUTPUT4	BOOM-X6 pin 7	Coax w/8
8	OUTPUT RET	BOOM-X6 pin 8	Coax Shield w/7
9	Spare		
10	Test RET	BOOM-X6 pin 10	Coax Shield w/11
11	Test	BOOM-X6 pin 11	Coax w/10
12	Ground	BOOM-X6 pin 12	#26 TT w/13,14
13	+5V	BOOM-X6 pin 13	#26 TT w/12,14
14	-5V	BOOM-X6 pin 14	#26 TT w/12,13
15	Bias	BOOM-X6 pin 15	#26
16	-12V	BOOM-X6 pin 16	#26
17	Cover2	BOOM-X6 pin 17	#26
18	Cover1	BOOM-X6 pin 18	#26
19	Door Close Act.	BOOM-X6 pin 19	#26 TT w/20,21
20	Door Open Act.	BOOM-X6 pin 20	#26 TT w/19,21
21	Door Act. RET	BOOM-X6 pin 21	#26 TT w/19,20
22	Spare		
23	Spare		
24	STE Temp	BOOM-X6 pin 24	#26 TP w/25
25	STE Temp RET	BOOM-X6 pin 25	#26 TP w/24
26	Chassis (connected to chassis)		

4.3.6.1 BOOM-X6 (STE-U)

Pin	Signal	Destination	Harness
1	OUTPUT1	BOOM-J6 pin 1	Coax w/2
2	OUTPUT RET	BOOM-J6 pin 2	Coax Shield w/1
3	OUTPUT2	BOOM-J6 pin 3	Coax w/4
4	OUTPUT RET	BOOM-J6 pin 4	Coax Shield w/3
5	OUTPUT3	BOOM-J6 pin 5	Coax w/6
6	OUTPUT RET	BOOM-J6 pin 6	Coax Shield w/5
7	OUTPUT4	BOOM-J6 pin 7	Coax w/8
8	OUTPUT RET	BOOM-J6 pin 8	Coax Shield w/7
9	Spare		
10	Test RET	BOOM-J6 pin 10	Coax Shield w/11
11	Test	BOOM-J6 pin 11	Coax w/10
12	Ground	BOOM-J6 pin 12	#26 TT w/13,14
13	+5V	BOOM-J6 pin 13	#26 TT w/12,14
14	-5V	BOOM-J6 pin 14	#26 TT w/12,13
15	Bias	BOOM-J6 pin 15	#26
16	-12V	BOOM-J6 pin 16	#26
17	Cover2	BOOM-J6 pin 17	#26
18	Cover1	BOOM-J6 pin 18	#26
19	Door Close Act.	BOOM-J6 pin 19	#26 TT w/20,21
20	Door Open Act.	BOOM-J6 pin 20	#26 TT w/19,21
21	Door Act. RET	BOOM-J6 pin 21	#26 TT w/19,20
22	STE-U Temp Sensor	BOOM-J2 pin 3	#26 TP w/23
23	STE-U Temp Sensor RET	BOOM-J2 pin 8	#26 TP w/22
24	STE Temp	BOOM-J6 pin 24	#26 TP w/25
25	STE Temp RET	BOOM-J6 pin 25	#26 TP w/24
26	Chassis (connected to chassis)		

4.3.6.2 STE-U P1 (STE-U pig-tail)

Pin	Signal	Destination	Harness
1	OUTPUT1	STE-U	Coax w/2
2	OUTPUT RET	STE-U	Coax Shield w/1
3	OUTPUT2	STE-U	Coax w/4
4	OUTPUT RET	STE-U	Coax Shield w/3
5	OUTPUT3	STE-U	Coax w/6
6	OUTPUT RET	STE-U	Coax Shield w/5
7	OUTPUT4	STE-U	Coax w/8
8	OUTPUT RET	STE-U	Coax Shield w/7
9	Spare		
10	Test RET	STE-U	Coax Shield w/11
11	Test	STE-U	Coax w/10
12	Ground	STE-U	#26 TT w/13,14
13	+5V	STE-U	#26 TT w/12,14
14	-5V	STE-U	#26 TT w/12,13
15	Bias	STE-U	#26
16	-12V	STE-U	#26
17	Cover2	STE-U	#26
18	Cover1	STE-U	#26
19	Door Close Act.	STE-U	#26 TT w/20,21
20	Door Open Act.	STE-U	#26 TT w/19,21
21	Door Act. RET	STE-U	#26 TT w/19,20
22	S/C Temp Sensor	STE-U *	#26 TP w/23
23	S/C Temp Sensor RET	STE-U *	#26 TP w/22
24	STE Temp	STE-U	#26 TP w/25
25	STE Temp RET	STE-U	#26 TP w/24
26	Chassis (connected to chassis)		

* S/C temp sensor is mounted to the inside of the ring captured to the STE-U harness that bolts to the STE-U chassis.

4.3.7. SWEA-P1 (IDPU to SWEA)

Pin	Signal	Destination	Harness
1	Chassis (connected in SWEA to SWEA chassis)		TSP shields
2	TLM-RET	BOOM-J4 pin 12	Coax Shield w/9
3	SWEA Temp.	BOOM-J2 pin 1	#26 TSP w/5
4	CMD-RET	BOOM-J4 pin 7	Coax Shield w/10
5	SWEA Temp. RET	BOOM-J2 pin 6	#26 TSP w/3
6	CLK-RET	BOOM-J4 pin 2	Coax Shield w/11
7	+28V Heater	BOOM-J1 pin 5	#26 TSP w/15
8	+28V	BOOM-J1 pin 2	#26 TSP w/14
9	TLM	BOOM-J4 pin 11	Coax w/2
10	CMD	BOOM-J4 pin 6	Coax w/4
11	CLK	BOOM-J4 pin 1	Coax w/6
12	Spare		
13	Spare		
14	+28V RET	BOOM-J1 pin 10	#26 TSP w/8
15	+28V Heater RET	BOOM-J1 pin 13	#26 TSP w/7

4.3.8. MAG-J1 (IDPU to MAG)

Pin	Signal	Destination	Harness
1	XYZ Drive	BOOM-J5 pin 1	Coax w/9
2	X Sensor Sig	BOOM-J5 pin 2	Coax w/10
3	Y Sensor Sig	BOOM-J5 pin 3	Coax w/11
4	Z Sensor Sig	BOOM-J5 pin 4	Coax w/12
5	MAG Temp Sensor	BOOM-J5 pin 5	#26 TSP w/13,14
6	MAG Heater	BOOM-J5 pin 6	#26 TSP w/7,8
7	MAG Heater RET	BOOM-J5 pin 7	#26 TSP w/6,8
8	MAG Heater Shield	BOOM-J5 pin 8	#26 TSP Shield
9	XYZ Drive RET, T2 Ret	BOOM-J5 pin 9	Coax Shield w/1
10	X Sensor Sig RET	BOOM-J5 pin 10	Coax Shield w/2
11	Y Sensor Sig RET	BOOM-J5 pin 11	Coax Shield w/3
12	Z Sensor Sig RET	BOOM-J5 pin 12	Coax Shield w/4
13	MAG Temp Sensor RET	BOOM-J5 pin 13	#26 TSP w/5,14
14	MAG Temp Sensor Shield, T2	BOOM-J5 pin 14	#26 TSP Shield
15	Chassis (Connect to thermal blanket ground at MAG)	Boom chassis ground	Overshield & Backshell

The wire bundle up the boom consists of the wires to MAG-J1 and SWEA-P1. This includes 7 coaxes and 5 twisted shielded pairs. A common over-shield shall be tied to chassis ground at both ends (the bottom of the boom and SWEA; MAG thermal blankets should also be connected to over-shield ground). For most of the length of the harness, the stacer shall be the outer shield; for the extension from SWEA to the MAG a shield will be added.

4.4. SWEA Connectors

4.4.1. SWEA-P1 (IDPU to SWEA)

See section 4.3.6

4.4.2. SWEA-P3 (HV/Actuator Enable)

Pin	Signal	Destination	Harness
13	28V Supply (sec)	SWEA-P3 pin 11	
12	28V Supply (sec)	SWEA-P3 pin 2	
15	SWEA Cover Act. Supply	SWEA-P3 pin 8	
10	STE Cover Open Act. Supply	SWEA-P3 pin 4	
9	STE Cover Close Act. Supply	SWEA-P3 pin 7	
11	28V MCP HV	SWEA-P3 pin 13	
2	28V NC HV	SWEA-P3 pin 12	
8	SWEA Cover Act.	SWEA P3-pin 15	
4	STE Cover Open Act.	SWEA-P3 pin 10	
7	STE Cover Close Act.	SWEA-P3 pin 9	
14	28V Supply RET (pri, SWEA Act)		
5	RET (sec, HV, STE Act)		
6	RET (sec, HV, STE Act)		
3	RET (sec, HV, STE Act)		
1	RET (sec, HV, STE Act)		

Note: The RET signals are for test purposes (a dummy load/indicator can be installed between the supply and RET signals to verify operation)

4.5. SEP Connectors

4.5.1. SEP-P1 (SEP Power)

Pin	Signal	Destination	Harness
1	Spare		
2	+28V Primary	Spacecraft	#26 TSQ w/3,10,11
3	+28V Redundant	Spacecraft	#26 TSQ w/2,10,11
4	Spare		
5	+28V Heater Primary	Spacecraft	#26 TSQ w/6,13,14
6	+28V Heater Redundant	Spacecraft	#26 TSQ w/5,13,14
7	Spare		
8	Chassis (connected in SEP to SEP chassis)		
9	Spare		
10	+28V Return Primary	Spacecraft	#26 TSQ w/2,3,11
11	+28V Return Redundant	Spacecraft	#26 TSQ w/2,3,10
12	Spare		
13	+28V Heater Return Primary	Spacecraft	#26 TSQ w/5,6,14
14	+28V Heater Return Redundant	Spacecraft	#26 TSQ w/5,6,13
15	Spare		

4.5.2. SEP-P2 (SEP S/C Temp. Sensors)

Pin	Signal	Destination	Harness
1	SEP Temp Sensor	Spacecraft	#24 TP w/9
2	SEPT-NS Temp Sensor	Spacecraft	#24 TP w/10
3	SIT S/C TEMP	Spacecraft	#24 TP w/11
4	SEPT-E S/C TEMP	Spacecraft	#24 TP w/12
5	HET S/C TEMP	Spacecraft	#24 TP w/13
6	LET S/C TEMP	Spacecraft	#24 TP w/14
7	Spare		
8	Spare		
9	SEP Temp Sensor RTN	Spacecraft	#24 TP w/1
10	SEPT-NS S/C TEMP RTN	Spacecraft	#24 TP w/2
11	SIT S/C TEMP RTN	Spacecraft	#24 TP w/3
12	SEPT-E S/C TEMP RTN	Spacecraft	#24 TP w/4
13	HET S/C TEMP RTN	Spacecraft	#24 TP w/5
14	LET S/C TEMP RTN	Spacecraft	#24 TP w/6
15	Chassis (connected in SEP to SEP chassis)		

4.5.3. SEP-P3 (SIT & SEPT Cover Actuators)

(Reconfigured, see 4.6.3; 4.7.3 and 4.8.3)

4.5.4. SEP-P4 (SEP to IDPU)

Pin	Signal	Destination	Harness
1	CLK	IDPU-P4 pin 1	Coax w/2
2	CLK-RET	IDPU-P4 pin 2	Coax Shield w/1
3	Spare		
4	Spare		
5	Spare		
6	CMD	IDPU-P4 pin 6	Coax w/7
7	CMD-RET	IDPU-P4 pin 7	Coax Shield w/6
8	Spare		
9	Spare		
10	Spare		
11	TLM	IDPU-P4 pin 11	Coax w/12
12	TLM-RET	IDPU-P4 pin 12	Coax Shield w/11
13	Spare		
14	Spare		
15	Chassis (connected in SEP to SEP chassis)		

(Note: This is a 1:1 harness)

4.5.5. SEP-P5 (SEP to SIT)

Pin	Signal	Destination	Harness
1	SIT +5.1A RTN	SIT-P1 pin 1	#26 TQ w/19,20,36
2	SIT Bias	SIT-P1 pin 2	#28 TP w/3
3	SIT Bias	SIT-P1 pin 3	#28 TP w/2
4	SIT +13A	SIT-P1 pin 4	#26
5	SIT -13A	SIT-P1 pin 5	#26
6	SIT -6A	SIT-P1 pin 6	#26
7	SIT +3.4D	SIT-P1 pin 7	#26
8	SIT -6A	SIT-P1 in 8	#26
9	SIT +5.1D	SIT-P1 pin 9	#26
10	SIT MSTR RTN	SIT-P1 pin 10	#28 TS14
11	SIT CMD IN	SIT-P1 pin 11	#28 TS14
12	SIT CMD OUT	SIT-P1 pin 12	#28 TS14
13	SIT DATA OUT	SIT-P1 pin 13	#28 TS14
14	SIT S/C TEMP	SIT-P1 pin 14	#28 TQ w/30,31,49
15	SIT DATA OUT	SIT-P1 pin 15	#28 TS14
16	SIT OP HTR	SIT-P1 pin 16	#28 TS8
17	SIT INNER SHIELD	SIT-P1 pin 17	Shield for TS14
18	SIT SURV HTR	SIT-P1 pin 18	#28 TS8
19	SIT +5.1A	SIT-P1 pin 19	#26 TQ w/1,20,36
20	SIT +5.1A RTN	SIT-P1 pin 20	#26 TQ w/1,19,36
21	SIT PWR RTN	SIT-P1 pin 21	#26
22	SIT +13A	SIT-P1 pin 22	#26
23	SIT +6A	SIT-P1 pin 23	#26
24	SIT -13A	SIT-P1 pin 24	#26
25	SIT -5.2D	SIT-P1 pin 25	#26
26	SIT +3.4D	SIT-P1 pin 26	#26
27	SIT CMD IN	SIT-P1 pin 27	#28 TS14
28	SIT CMD OUT	SIT-P1 pin 28	#28 TS14
29	SIT SUB RTN	SIT-P1 pin 29	#28 TS14
30	SIT S/C TEMP	SIT-P1 pin 30	#28 TQ w/14,31,49
31	SIT S/C TEMP RTN	SIT-P1 pin 31	#28 TQ w/14,30,49
32	SIT OP HTR	SIT-P1 pin 32	#28 TS8
33	SIT OP HTR RTN	SIT-P1 pin 33	#28 TS8
34	SIT SURV HTR	SIT-P1 pin 34	#28 TS8
35	SIT SURV HTR RTN	SIT-P1 pin 35	#28 TS8
36	SIT +5.1A RTN	SIT-P1 pin 36	#26 TQ w/1,19,20
37	SIT PWR RTN	SIT-P1 pin 37	#26
38	SIT +6A	SIT-P1 pin 38	#26
39	SIT -5.2D	SIT-P1 pin 39	#26
40	SIT +2.6D	SIT-P1 pin 40	#26
41	SIT +2.6D	SIT-P1 pin 41	#26

42	SIT +5.1D	SIT-P1 pin 42	#26
43	SIT RESET	SIT-P1 pin 43	#28 TS14
44	SIT RESET	SIT-P1 pin 44	#28 TS14
45	SIT MSTR RTN	SIT-P1 pin 45	#28 TS14
46	SIT FRAME SYNC	SIT-P1 pin 46	#28 TS14
47	SIT FRAME SYNC	SIT-P1 pin 47	#28 TS14
48	SIT SUB RTN	SIT-P1 pin 48	#28 TS14
49	SIT S/C TEMP RTN	SIT-P1 pin 49	#28 TQ w/14,30,31
50	SIT OP HTR RTN	SIT-P1 pin 50	#28 TS8
51	SIT SURV HTR RTN	SIT-P1 pin 51	#28 TS8

(Note: This is a 1:1 harness)

Shield for TS8, along with over-shield, terminated on connector backshell

4.5.6. SEP-P6 (SEP to SEPT-NS)

Removed

4.5.7. SEP-P7 (SEP to SEPT-NS)

Pin	Signal	Destination	Harness
1	SEPT-NS Bias	SEPTNS-P2 pin 1	#28 TQ w/2,20,21
2	SEPT-NS Bias RTN	SEPTNS-P2 pin 2	#28 TQ w/1,20,21
3	SEPT-NS Ana RTN	SEPTNS-P2 pin 3	#28 TQ w/4,22,23
4	SEPT-NS +5.6VA	SEPTNS-P2 pin 4	#28 TQ w/4,22,23
5	SEPT-NS Dig RTN	SEPTNS-P2 pin 5	#28 T6 w/6,7,24,25,26
6	SEPT-NS +2.6VD	SEPTNS-P2 pin 6	#28 T6 w/5,7,24,25,26
7	SEPT-NS +5.3VD	SEPTNS-P2 pin 7	#28 T6 w/5,6,24,25,26
8	SEPT-NS Star Ground	SEPTNS-P2 pin 8	#28
9	SEPT-NS Cmd In	SEPTNS-P2 pin 9	#28 TS8 w/10,11,12,28,29,30,31
10	SEPT-NS Mstr RTN	SEPTNS-P2 pin 10	#28 TS8 w/9,11,12,28,29,30,31
11	SEPT-NS Data Out	SEPTNS-P2 pin 11	#28 TS8 w/9,10,12,28,29,30,31
12	SEPT-NS Sub RTN	SEPTNS-P2 pin 12	#28 TS8 w/9,10,11,28,29,30,31
13	SEPT-NS S/C Temp	SEPTNS-P2 pin 13	#28 TQ w/14,32,33
14	SEPT-NS S/C Temp RTN	SEPTNS-P2 pin 14	#28 TP w/13,32,33
15	SEPT-NS Op Htr	SEPTNS-P1 pin 1	#28 TS8 w/16,17,18,34,35,36,37
16	SEPT-NS Op Htr RTN	SEPTNS-P1 pin 2	#28 TS8 w/15,16,17,34,35,36,37
17	SEPT-NS Survival Htr	SEPTNS-P1 pin 3	#28 TS8 w/15,16,18,34,35,36,37
18	SEPT-NS Survival Htr RTN	SEPTNS-P1 pin 4	#28 TS8 w/15,16,17,34,35,36,37
19	SEPT-NS Internal Shield	SEPTNS-P2 pin 16	TS8 shield (10,11,etc.)
20	SEPT-NS Bias Red.	SEPTNS-P2 pin 17	#28 TQ w/1,2,21
21	SEPT-NS Bias RTN Red.	SEPTNS-P2 pin 18	#28 TQ w/1,2,20
22	SEPT-NS Ana RTN Red.	SEPTNS-P2 pin 19	#28 TQ w/3,4,23
23	SEPT-NS +5.6VA Red.	SEPTNS-P2 pin 20	#28 TQ w/3,4,22
24	SEPT-NS Dig RTN Red.	SEPTNS-P2 pin 21	#28 T6 w/5,6,7,25,26
25	SEPT-NS +2.6VD Red.	SEPTNS-P2 pin 22	#28 T6 w/5,6,7,24,26
26	SEPT-NS +5.3VD Red.	SEPTNS-P2 pin 23	#28 T6 w/5,6,7,24,25
27	SEPT-NS Star Ground Red.	SEPTNS-P2 pin 24	#28
28	SEPT-NS Cmd In Red.	SEPTNS-P2 pin 25	#28 TS8 w/9,10,11,12,29,30,31
29	SEPT-NS Mstr RTN Red.	SEPTNS-P2 pin 26	#28 TS8 w/9,10,11,12,28,30,31
30	SEPT-NS Data Out Red.	SEPTNS-P2 pin 27	#28 TS8 w/9,10,11,12,28,29,31
31	SEPT-NS Sub RTN Red.	SEPTNS-P2 pin 28	#28 TS8 w/9,10,11,12,28,29,30
32	SEPT-NS S/C Temp Red	SEPTNS-P2 pin 29	#28 TQ w/13,14,33
33	SEPT-NS S/C Temp RTN Red.	SEPTNS-P2 pin 30	#28 TQ w/13,14,32
34	SEPT-NS Op Htr Red.	SEPTNS-P1 pin 6	#28 TS8 w/15,16,17,18,35,36,37
35	SEPT-NS Op Htr RTN Red.	SEPTNS-P1 pin 7	#28 TS8 w/15,16,17,18,34,36,37
36	SEPT-NS Survival Htr Red.	SEPTNS-P1 pin 3	#28 TS8 w/15,16,17,18,34,35,37
37	SEPT-NS Survival Htr RTN Red.	SEPTNS-P1 pin 4	#28 TS8 w/15,16,17,18,34,35,36 (TS8 shield to backshell)

4.5.8. SEP-P8 (SEP to SEPT-E)

Removed

4.5.9. SEP-P9 (SEP to SEPT-E)

Pin	Signal	Destination	Harness
1	SEPT-E Bias	SEPTE-P2 pin 1	#28 TQ w/2,20,21
2	SEPT-E Bias RTN	SEPTE-P2 pin 2	#28 TQ w/1,20,21
3	SEPT-E Ana RTN	SEPTE-P2 pin 3	#28 TQ w/4,22,23
4	SEPT-E +5.6VA	SEPTE-P2 pin 4	#28 TQ w/4,22,23
5	SEPT-E Dig RTN	SEPTE-P2 pin 5	#28 T6 w/6,7,24,25,26
6	SEPT-E +2.6VD	SEPTE-P2 pin 6	#28 T6 w/5,7,24,25,26
7	SEPT-E +5.3VD	SEPTE-P2 pin 7	#28 T6 w/5,6,24,25,26
8	SEPT-E Star Ground	SEPTE-P2 pin 8	#28
9	SEPT-E Cmd In	SEPTE-P2 pin 9	#28 TS8 w/10,11,12,28,29,30,31
10	SEPT-E Mstr RTN	SEPTE-P2 pin 10	#28 TS8 w/9,11,12,28,29,30,31
11	SEPT-E Data Out	SEPTE-P2 pin 11	#28 TS8 w/9,10,12,28,29,30,31
12	SEPT-E Sub RTN	SEPTE-P2 pin 12	#28 TS8 w/9,10,11,28,29,30,31
13	SEPT-E S/C Temp	SEPTE-P2 pin 13	#28 TQ w/14,32,33
14	SEPT-E S/C Temp RTN	SEPTE-P2 pin 14	#28 TP w/13,32,33
15	SEPT-E Op Htr	SEPTE-P1 pin 1	#28 TS8 w/16,17,18,34,35,36,37
16	SEPT-E Op Htr RTN	SEPTE-P1 pin 2	#28 TS8 w/15,16,17,34,35,36,37
17	SEPT-E Survival Htr	SEPTE-P1 pin 3	#28 TS8 w/15,16,18,34,35,36,37
18	SEPT-E Survival Htr RTN	SEPTE-P1 pin 4	#28 TS8 w/15,16,17,34,35,36,37
19	SEPT-E Internal Shield	SEPTE-P2 pin 16	TS8 shield (10,11,etc.)
20	SEPT-E Bias Red.	SEPTE-P2 pin 17	#28 TQ w/1,2,21
21	SEPT-E Bias RTN Red.	SEPTE-P2 pin 18	#28 TQ w/1,2,20
22	SEPT-E Ana RTN Red.	SEPTE-P2 pin 19	#28 TQ w/3,4,23
23	SEPT-E +5.6VA Red.	SEPTE-P2 pin 20	#28 TQ w/3,4,22
24	SEPT-E Dig RTN Red.	SEPTE-P2 pin 21	#28 T6 w/5,6,7,25,26
25	SEPT-E +2.6VD Red.	SEPTE-P2 pin 22	#28 T6 w/5,6,7,24,26
26	SEPT-E +5.3VD Red.	SEPTE-P2 pin 23	#28 T6 w/5,6,7,24,25
27	SEPT-E Star Ground Red.	SEPTE-P2 pin 24	#28
28	SEPT-E Cmd In Red.	SEPTE-P2 pin 25	#28 TS8 w/9,10,11,12,29,30,31
29	SEPT-E Mstr RTN Red.	SEPTE-P2 pin 26	#28 TS8 w/9,10,11,12,28,30,31
30	SEPT-E Data Out Red.	SEPTE-P2 pin 27	#28 TS8 w/9,10,11,12,28,29,31
31	SEPT-E Sub RTN Red.	SEPTE-P2 pin 28	#28 TS8 w/9,10,11,12,28,29,30
32	SEPT-E S/C Temp Red	SEPTE-P2 pin 29	#28 TQ w/13,14,33
33	SEPT-E S/C Temp RTN Red.	SEPTE-P2 pin 30	#28 TQ w/13,14,32
34	SEPT-E Op Htr Red.	SEPTE-P1 pin 6	#28 TS8 w/15,16,17,18,35,36,37
35	SEPT-E Op Htr RTN Red.	SEPTE-P1 pin 7	#28 TS8 w/15,16,17,18,34,36,37
36	SEPT-E Survival Htr Red.	SEPTE-P1 pin 3	#28 TS8 w/15,16,17,18,34,35,37
37	SEPT-E Survival Htr RTN Red.	SEPTE-P1 pin 4	#28 TS8 w/15,16,17,18,34,35,36 (TS8 shield to backshell)

4.6. SEPT-E Connectors

4.6.1. SEPT-E-P1 (SEP to SEPT-E)

Pin	Signal	Destination	Harness
1	SEPT-E Op Htr	SEP-P9 pin 15	#28 TS8 w/16,17,18,34,35,36,37
2	SEPT-E Op Htr RTN	SEP-P9 pin 16	#28 TS8 w/15,16,17,34,35,36,37
3	SEPT-E Survival Htr	SEP-P9 pin 17	#28 TS8 w/15,16,18,34,35,36,37
4	SEPT-E Survival Htr RTN	SEP-P9 pin 18	#28 TS8 w/15,16,17,34,35,36,37
5	SEPT-E Chassis Ground		
6	SEPT-E Op Htr Red.	SEP-P9 pin 34	#28 TS8 w/15,16,17,18,35,36,37
7	SEPT-E Op Htr RTN Red.	SEP-P9 pin 35	#28 TS8 w/15,16,17,18,34,36,37
8	SEPT-E Survival Htr Red.	SEP-P9 pin 36	#28 TS8 w/15,16,17,18,34,35,37
9	SEPT-E Survival Htr RTN Red.	SEP-P9 pin 37	#28 TS8 w/15,16,17,18,34,35,36 (TS8 shield to backshell)

4.6.2. SEPT-E-P2 (SEP to SEPT-E)

Pin	Signal	Destination	Harness
1	SEPT-E Bias	SEP-P9 pin 1	#28 TQ w/2,17,18
2	SEPT-E Bias RTN	SEP-P9 pin 2	#28 TQ w/1,17,18
3	SEPT-E Ana RTN	SEP-P9 pin 3	#28 TQ w/4,19,20
4	SEPT-E +5.6VA	SEP-P9 pin 4	#28 TQ w/4,19,20
5	SEPT-E Dig RTN	SEP-P9 pin 5	#28 T6 w/6,7,21,22,23
6	SEPT-E +2.6VD	SEP-P9 pin 6	#28 T6 w/5,7,21,22,23
7	SEPT-E +5.3VD	SEP-P9 pin 7	#28 T6 w/5,6,21,22,23
8	SEPT-E Star Ground	SEP-P9 pin 8	#28
9	SEPT-E Cmd In	SEP-P9 pin 9	#28 TS8 w/10,11,12,25,26,27,28
10	SEPT-E Mstr RTN	SEP-P9 pin 10	#28 TS8 w/9,11,12, 25,26,27,28
11	SEPT-E Data Out	SEP-P9 pin 11	#28 TS8 w/9,10,12, 25,26,27,28
12	SEPT-E Sub RTN	SEP-P9 pin 12	#28 TS8 w/9,10,11, 25,26,27,28
13	SEPT-E S/C Temp	SEP-P9 pin 13	#28 TQ w/14,29,30
14	SEPT-E S/C Temp RTN	SEP-P9 pin 14	#28 TQ w/13,29,30
15	Spare		
16	SEPT-E Internal Shield	SEP-P9 pin 19	TS8 shield (10,11,etc.)
17	SEPT-E Bias Red.	SEP-P9 pin 20	#28 TQ w/1,2,18
18	SEPT-E Bias RTN Red.	SEP-P9 pin 21	#28 TQ w/1,2,17
19	SEPT-E Ana RTN Red.	SEP-P9 pin 22	#28 TQ w/3,4,23
20	SEPT-E +5.6VA Red.	SEP-P9 pin 23	#28 TQ w/3,4,22
21	SEPT-E Dig RTN Red.	SEP-P9 pin 24	#28 T6 w/5,6,7,25,26
22	SEPT-E +2.6VD Red.	SEP-P9 pin 25	#28 T6 w/5,6,7,24,26
23	SEPT-E +5.3VD Red.	SEP-P9 pin 26	#28 T6 w/5,6,7,24,25
24	SEPT-E Star Ground Red.	SEP-P9 pin 27	#28
25	SEPT-E Cmd In Red.	SEP-P9 pin 28	#28 TS8 w/9,10,11,12,26,27,28

26	SEPT-E Mstr RTN Red.	SEP-P9 pin 29	#28 TS8 w/9,10,11,12,25,27,28
27	SEPT-E Data Out Red.	SEP-P9 pin 30	#28 TS8 w/9,10,11,12,25,26,28
28	SEPT-E Sub RTN Red.	SEP-P9 pin 31	#28 TS8 w/9,10,11,12,25,26,27
29	SEPT-E S/C Temp Red	SEP-P9 pin 32	#28 TQ w/13,14,30
	SEPT-E S/C Temp RTN	SEP-P9 pin 33	#28 TQ w/13,14,29
30	Red.		
31	Spare		

4.6.3. SEPT-E-P3 (S/C to SEPT-E)

Pin	Signal	Destination	Harness
1	SEPT-E ACT1	Spacecraft	#20 TSP w/3
2	SEPT-E ACT1	Spacecraft	#20 TSP w/4
3	SEPT-E ACT1 RTN	Spacecraft	#20 TSP w/1
4	SEPT-E ACT1 RTN	Spacecraft	#20 TSP w/2
5	SEPT-E chassis) Chassis (con. in SEPT-E to		
6	SEPT-E ACT2	Spacecraft	#20 TSP w/8
7	SEPT-E ACT2	Spacecraft	#20 TSP w/9
8	SEPT-E ACT2 RTN	Spacecraft	#20 TSP w/6
9	SEPT-E ACT2 RTN	Spacecraft	#20 TSP w/7

4.7. SEPT-NS Connectors

4.7.1. SEPTNS-P1 (SEP to SEPT-NS)

Pin	Signal	Destination	Harness
1	SEPT-NS Op Htr	SEP-P7 pin 15	#28 TS8 w/16,17,18,34,35,36,37
2	SEPT-NS Op Htr RTN	SEP-P7 pin 16	#28 TS8 w/15,16,17,34,35,36,37
3	SEPT-NS Survival Htr	SEP-P7 pin 17	#28 TS8 w/15,16,18,34,35,36,37
4	SEPT-NS Survival Htr RTN	SEP-P7 pin 18	#28 TS8 w/15,16,17,34,35,36,37
5	SEPT-NS Chassis Ground		
6	SEPT-NS Op Htr Red.	SEP-P7 pin 34	#28 TS8 w/15,16,17,18,35,36,37
7	SEPT-NS Op Htr RTN Red.	SEP-P7 pin 35	#28 TS8 w/15,16,17,18,34,36,37
8	SEPT-NS Survival Htr Red.	SEP-P7 pin 36	#28 TS8 w/15,16,17,18,34,35,37
9	SEPT-NS Survival Htr RTN Red.	SEP-P7 pin 37	#28 TS8 w/15,16,17,18,34,35,36 (TS8 shield to backshell)

4.7.2. SEPTNS-P2 (SEP to SEPT-NS)

Pin	Signal	Destination	Harness
1	SEPT-NS Bias	SEP-P7 pin 1	#28 TQ w/2,17,18
2	SEPT-NS Bias RTN	SEP-P7 pin 2	#28 TQ w/1,17,18
3	SEPT-NS Ana RTN	SEP-P7 pin 3	#28 TQ w/4,19,20
4	SEPT-NS +5.6VA	SEP-P7 pin 4	#28 TQ w/4,19,20
5	SEPT-NS Dig RTN	SEP-P7 pin 5	#28 T6 w/6,7,21,22,23
6	SEPT-NS +2.6VD	SEP-P7 pin 6	#28 T6 w/5,7,21,22,23
7	SEPT-NS +5.3VD	SEP-P7 pin 7	#28 T6 w/5,6,21,22,23
8	SEPT-NS Star Ground	SEP-P7 pin 8	#28
9	SEPT-NS Cmd In	SEP-P7 pin 9	#28 TS8 w/10,11,12,25,26,27,28
10	SEPT-NS Mstr RTN	SEP-P7 pin 10	#28 TS8 w/9,11,12, 25,26,27,28
11	SEPT-NS Data Out	SEP-P7 pin 11	#28 TS8 w/9,10,12, 25,26,27,28
12	SEPT-NS Sub RTN	SEP-P7 pin 12	#28 TS8 w/9,10,11, 25,26,27,28
13	SEPT-NS S/C Temp	SEP-P7 pin 13	#28 TQ w/14,29,30
14	SEPT-NS S/C Temp RTN	SEP-P7 pin 14	#28 TQ w/13,29,30
15	Spare		
16	SEPT-NS Internal Shield	SEP-P7 pin 19	TS8 shield (10,11,etc.)
17	SEPT-NS Bias Red.	SEP-P7 pin 20	#28 TQ w/1,2,18
18	SEPT-NS Bias RTN Red.	SEP-P7 pin 21	#28 TQ w/1,2,17
19	SEPT-NS Ana RTN Red.	SEP-P7 pin 22	#28 TQ w/3,4,23
20	SEPT-NS +5.6VA Red.	SEP-P7 pin 23	#28 TQ w/3,4,22
21	SEPT-NS Dig RTN Red.	SEP-P7 pin 24	#28 T6 w/5,6,7,25,26
22	SEPT-NS +2.6VD Red.	SEP-P7 pin 25	#28 T6 w/5,6,7,24,26
23	SEPT-NS +5.3VD Red.	SEP-P7 pin 26	#28 T6 w/5,6,7,24,25
24	SEPT-NS Star Ground Red.	SEP-P7 pin 27	#28
25	SEPT-NS Cmd In Red.	SEP-P7 pin 28	#28 TS8 w/9,10,11,12,26,27,28
26	SEPT-NS Mstr RTN Red.	SEP-P79 pin 29	#28 TS8 w/9,10,11,12,25,27,28

27	SEPT-NS Data Out Red.	SEP-P7 pin 30	#28 TS8 w/9,10,11,12,25,26,28
28	SEPT-NS Sub RTN Red.	SEP-P7 pin 31	#28 TS8 w/9,10,11,12,25,26,27
29	SEPT-NS S/C Temp Red	SEP-P7 pin 32	#28 TQ w/13,14,30
30	SEPT-NS S/C Temp RTN	SEP-P7 pin 33	#28 TQ w/13,14,29
31	Red. Spare		

4.7.3. SEPTNS-P3 (S/C to SEPT-NS)

Pin	Signal	Destination	Harness
1	SEPT-NS ACT1	Spacecraft	#20 TSP w/3
2	SEPT-NS ACT1	Spacecraft	#20 TSP w/4
3	SEPT-NS ACT1 RTN	Spacecraft	#20 TSP w/1
4	SEPT-NS ACT1 RTN	Spacecraft	#20 TSP w/2
5	Chassis (con. in SEPT-NS to SEPT-NS chassis)		
6	SEPT-NS ACT2	Spacecraft	#20 TSP w/8
7	SEPT-NS ACT2	Spacecraft	#20 TSP w/9
8	SEPT-NS ACT2 RTN	Spacecraft	#20 TSP w/6
9	SEPT-NS ACT2 RTN	Spacecraft	#20 TSP w/7

4.8. SIT Connectors

4.8.1. SIT-P1 (SEP to SIT)

Pin	Signal	Destination	Harness
1	SIT +5.1A RTN	SEP-P5 pin 1	#26 TQ w/19,20,36
2	SIT Bias	SEP-P5 pin 2	#28 TP w/3
3	SIT Bias	SEP-P5 pin 3	#28 TP w/2
4	SIT +13A	SEP-P5 pin 4	#26
5	SIT -13A	SEP-P5 pin 5	#26
6	SIT -6A	SEP-P5 pin 6	#26
7	SIT +3.4D	SEP-P5 pin 7	#26
8	SIT -6A	SEP-P5 pin 8	#26
9	SIT +5.1D	SEP-P5 pin 9	#26
10	SIT MSTR RTN	SEP-P5 pin 10	#28 TS14
11	SIT CMD IN	SEP-P5 pin 11	#28 TS14
12	SIT CMD OUT	SEP-P5 pin 12	#28 TS14
13	SIT DATA OUT	SEP-P5 pin 13	#28 TS14
14	SIT S/C TEMP	SEP-P5 pin 14	#28 TQ w/30,31,49
15	SIT DATA OUT	SEP-P5 pin 15	#28 TS14
16	SIT OP HTR	SEP-P5 pin 16	#28 TS8
17	SIT INNER SHIELD	SEP-P5 pin 17	Shield for TS14
18	SIT SURV HTR	SEP-P5 pin 18	#28 TS8
19	SIT +5.1A	SEP-P5 pin 19	#26 TQ w/1,20,36
20	SIT +5.1A RTN	SEP-P5 pin 20	#26 TQ w/1,19,36
21	SIT PWR RTN	SEP-P5 pin 21	#26
22	SIT +13A	SEP-P5 pin 22	#26
23	SIT +6A	SEP-P5 pin 23	#26
24	SIT -13A	SEP-P5 pin 24	#26
25	SIT -5.2D	SEP-P5 pin 25	#26
26	SIT +3.4D	SEP-P5 pin 26	#26
27	SIT CMD IN	SEP-P5 pin 27	#28 TS14
28	SIT CMD OUT	SEP-P5 pin 28	#28 TS14
29	SIT SUB RTN	SEP-P5 pin 29	#28 TS14
30	SIT S/C TEMP	SEP-P5 pin 30	#28 TQ w/14,31,49
31	SIT S/C TEMP RTN	SEP-P5 pin 31	#28 TQ w/14,30,49
32	SIT OP HTR	SEP-P5 pin 32	#28 TS8
33	SIT OP HTR RTN	SEP-P5 pin 33	#28 TS8
34	SIT SURV HTR	SEP-P5 pin 34	#28 TS8
35	SIT SURV HTR RTN	SEP-P5 pin 35	#28 TS8
36	SIT +5.1A RTN	SEP-P5 pin 36	#26 TQ w/1,19,20
37	SIT PWR RTN	SEP-P5 pin 37	#26
38	SIT +6A	SEP-P5 pin 38	#26
39	SIT -5.2D	SEP-P5 pin 39	#26

40	SIT +2.6D	SEP-P5 pin 40	#26
41	SIT +2.6D	SEP-P5 pin 41	#26
42	SIT +5.1D	SEP-P5 pin 42	#26
43	SIT RESET	SEP-P5 pin 43	#28 TS14
44	SIT RESET	SEP-P5 pin 44	#28 TS14
45	SIT MSTR RTN	SEP-P5 pin 45	#28 TS14
46	SIT FRAME SYNC	SEP-P5 pin 46	#28 TS14
47	SIT FRAME SYNC	SEP-P5 pin 47	#28 TS14
48	SIT SUB RTN	SEP-P5 pin 48	#28 TS14
49	SIT S/C TEMP RTN	SEP-P5 pin 49	#28 TQ w/14,30,31
50	SIT OP HTR RTN	SEP-P5 pin 50	#28 TS8
51	SIT SURV HTR RTN	SEP-P5 pin 51	#28 TS8

(Note: This is a 1:1 harness)

Shield for TS8, along with over-shield, terminated on connector backshell.

4.8.2. SIT-P2 (SIT HV Disable/Test)

TBD-SIT-004

4.8.3. SIT-P3 (S/C to SIT)

Pin	Signal	Destination	Harness
1	SIT ACT	Spacecraft	#20 TSP w/6
2	SIT ACT	Spacecraft	#20 TSP w/7
3	Spare		
4	Spare		
5	Spare		
6	SIT ACT RTN	Spacecraft	#20 TSP w/1
7	SIT ACT RTN	Spacecraft	#20 TSP w/2
8	Spare		
9	SIT chassis ground		

4.9. **PLASTIC Connectors**

4.9.1. PLA-J4 (IDPU to PLASTIC)

Pin	Signal	Destination	Harness
1	CLK	IDPU-P3 pin 1	Coax w/2
2	CLK-RET	IDPU-P3 pin 2	Coax Shield w/1
3	Spare		
4	Spare		
5	Spare		
6	CMD	IDPU-P3 pin 6	Coax w/7
7	CMD-RET	IDPU-P3 pin 7	Coax Shield w/6
8	Spare		
9	Spare		
10	Spare		
11	TLM	IDPU-P3 pin 11	Coax w/12
12	TLM-RET	IDPU-P3 pin 12	Coax Shield w/11
13	Spare		
14	Spare		
15	Spare		
16	Spare		
17	Spare		
18	Spare		
19	Spare		
20	Spare		
21	Spare		
22	Spare		
23	Spare		
24	Spare		
25	Chassis (connected in PLASTIC to chassis)		

5. Harness Shielding and Termination

The EMC requirements called out in reference 3 detail the shielding requirements for the STEREO harnesses.

- IMPACT has submitted a waiver against the requirement for 20 mils Aluminum equivalent shielding against deep dielectric discharge effects on harnesses exterior to the spacecraft (due to immunity of the signals to small discharges).
- All noisy signals shall be internally shielded as coax or foil over-wrap. Internal shields shall be connected to signal return at both ends.
- Power shall be twisted with return lines. Primary power lines are considered noisy and will be internally shielded.
- An over-shield shall be used, terminated to the connector backshells at both ends. This shield must have an insulating over-wrap for any portion of the cable that is internal to the spacecraft bus.
- The over-shield must be circumferentially terminated to the connector body.
- The over-shield shall be terminated to spacecraft structure where the harness penetrates the spacecraft body. It may also be terminated at selected locations along its route.
- Shield bonding from shield to connector shall be less than 2.5 milliohms.

Section 6 of this document outlines which harnesses UCB, APL, and Caltech build. Each institution uses somewhat different techniques. APL harness fabrication is discussed elsewhere. The internal boom harness is described elsewhere.

5.1. UCB Harnesses

UCB harnesses use standard and high density D connectors (see section 3). Glenair 557-186 composite backshells will be used, Glenair Aracon Braid shall be used for the harness over-shield, with Kapton tape over-wrap used inside the bus. See Figure 5.1-1.

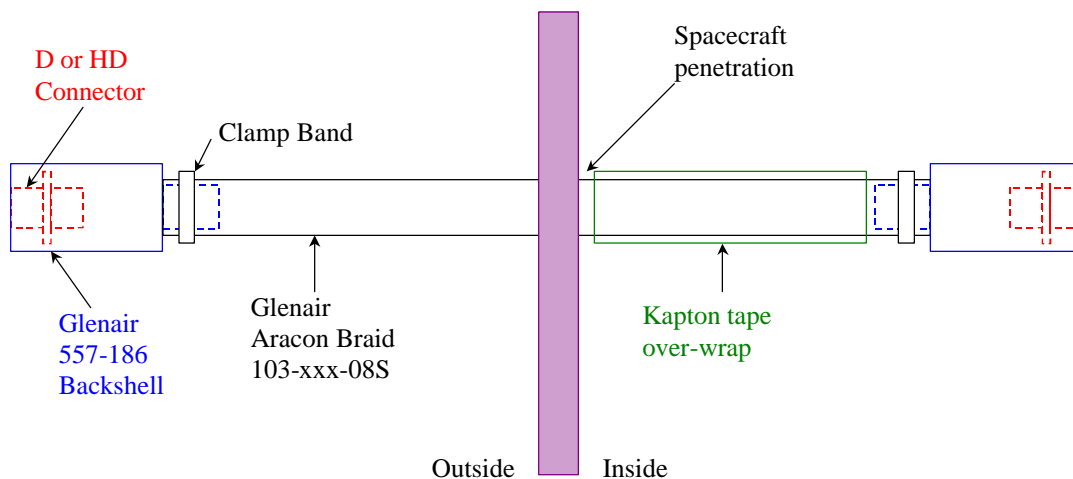

Figure 5.1-1 UCB Harness Fabrication

We have two sizes of the Aracon braid: 103-009-008S (1/4" ID) and 103-009-016S (1/2" ID). The small braid should be adequate for the IDPU-P3 to PLA-P4, IDPU-P4 to SEP-P4 and IDPU-P5 to BOOM-P4 harnesses. The larger will probably be required for IDPU-P6 to BOOM-P5 and IDPU-P7 to BOOM-P6 (use the smaller braid if it fits).

Backshells come in different connector sizes, different harness size, and different connector mounting schemes. The backshells to be used are:

Connector	Backshell
IDPU-P3	557T186XM1F0H0-02B
IDPU-P4	557T186XM1F0H0-02B
IDPU-P5	557T186XM1F0H0-02B
IDPU-P6	557T186XM1F0H0-02B
IDPU-P7	557T186XM2F0H0-04B
BOOM-P4	557T186XM1R3H0-02B
BOOM-P5	557T186XM1R3H0-02B
BOOM-P6	557T186XM2R3H0-04B
SEP-P4	557T186XM1R3H0-02B
PLA-P4	557T186XM3R4H0-02B

Coaxes shall be terminated and spliced to short individual wires that are attached to the connector pins. This splicing should take place inside the connector backshell if possible. Splicing should be done in such a way as to provide strain relief for the fragile coax connections.

Twisted shielded pairs shall be built up from foil-wrapped pairs extracted from the boom harness material. To avoid damage to the foil or shorting between foils and the braid, this material should be over-wrapped in kapton tape. The drain wire must be spliced to a jacketed wire or else tape-wrapped to avoid shorting with the braid or other shield wires.

In order to provide strain relief to the harness, the cable bundle (excluding over shield) shall be wrapped in kapton tape where it exists the connector backshell such that the shell clamps the harness.

The method of terminating the harness braid to the spacecraft structure at penetration (and perhaps other places) is TBD.

The method of tying down the cable to spacecraft structure is TBD

Harness manufacture must be performed in a clean area and meet the contamination requirements in reference 4, section 8.4.1.

Harnesses shall be built up using the APL spacecraft mock-ups.

Harness will be continuity-checked and hi-pot tested at APL after fabrication.

5.2. ***Caltech Harnesses***

The following two figures describe the Caltech harness design. Details of the fabrication are TBD.

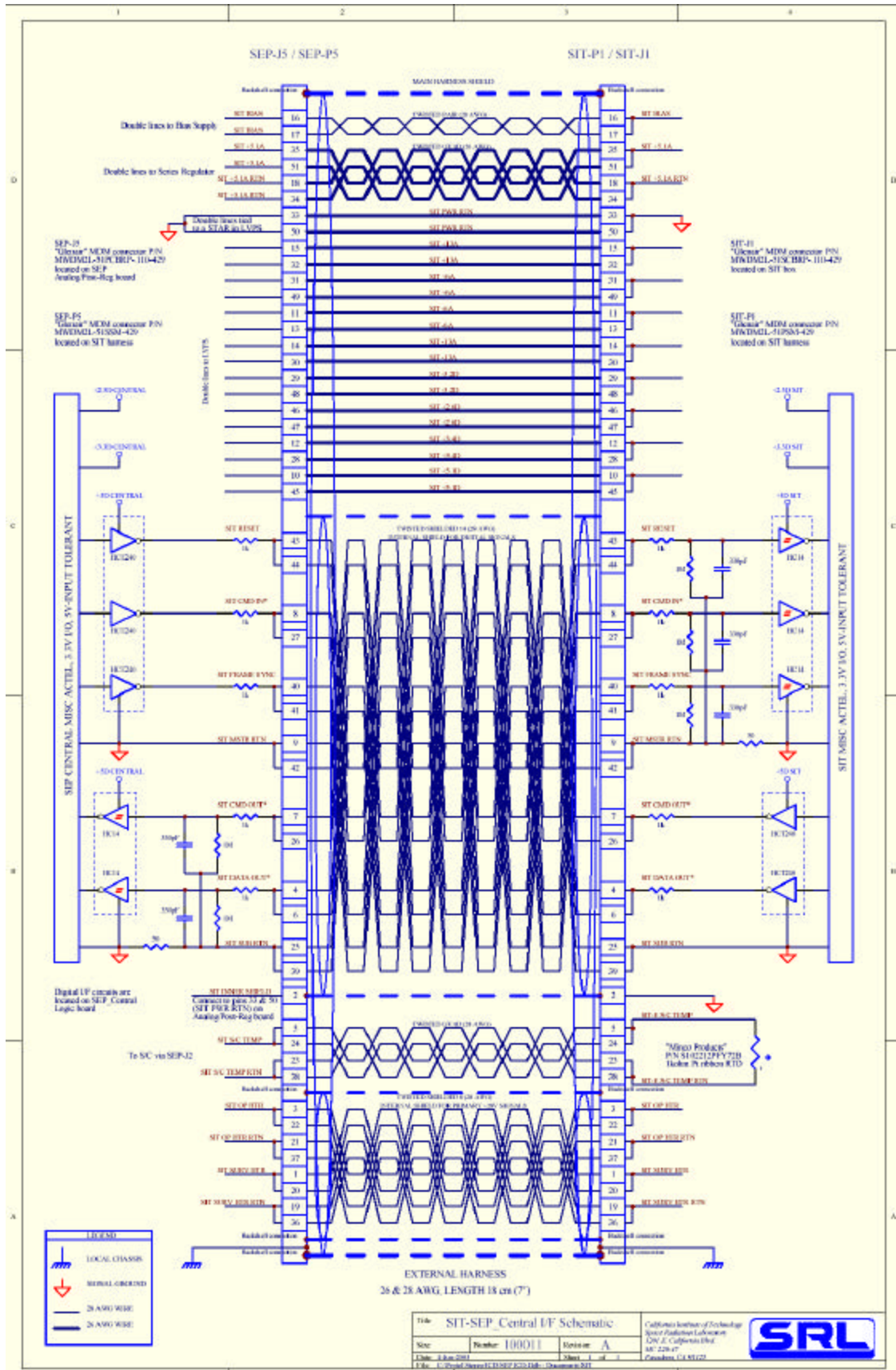

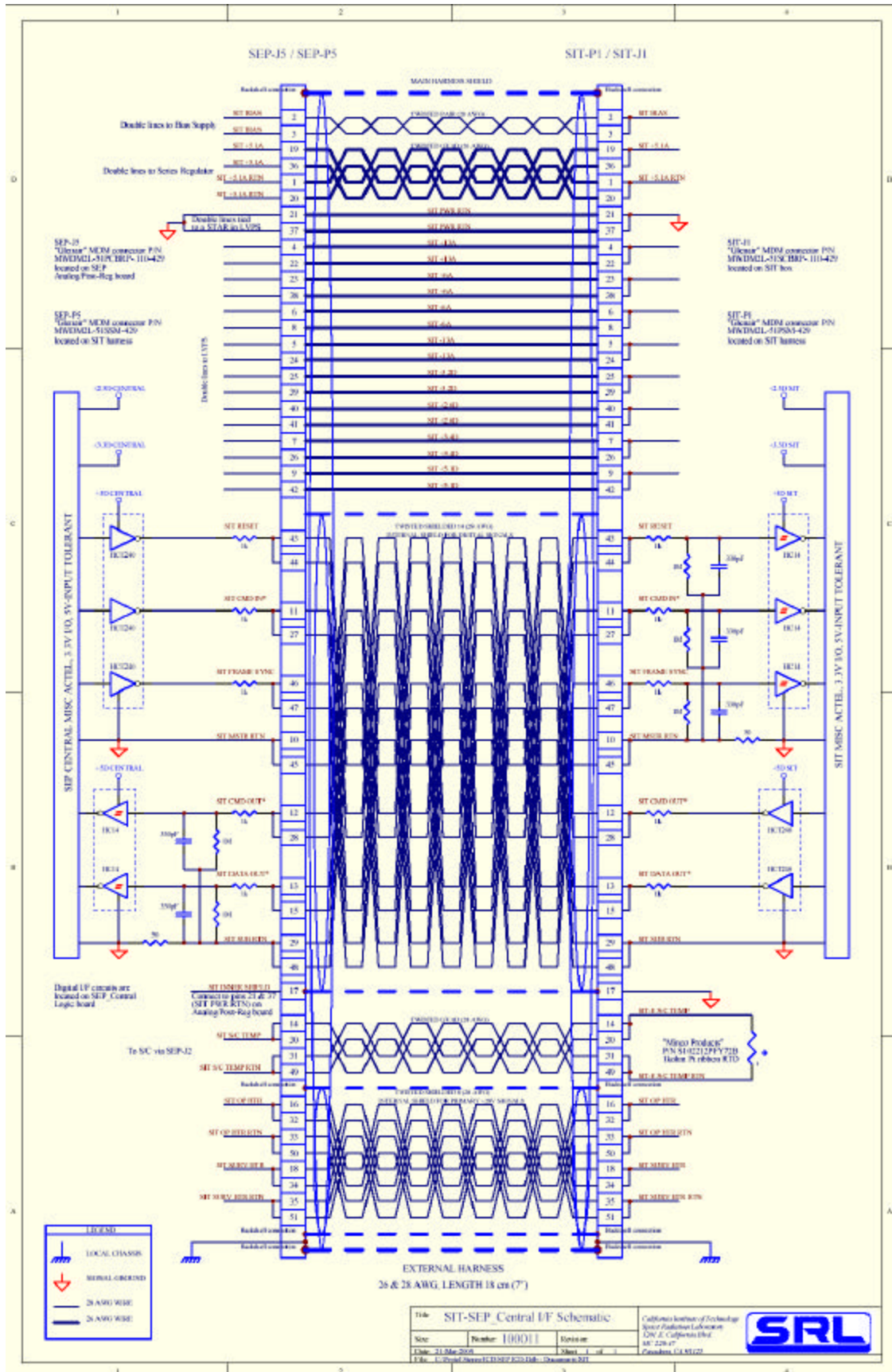

6. Harness Responsibilities

APL is responsible for the harness between the spacecraft systems and IMPACT, including the harnesses to:

- IDPU-P1
- IDPU-P2
- BOOM-P1
- BOOM-P2
- BOOM-P3
- SEP-P1
- SEP-P2
- SIT-P3
- SEPTE-P3
- SEPTNS-P3

UCB is responsible for the harness between PLASTIC and IDPU-P3

UCB is responsible for the following harnesses:

- IDPU-P4 to SEP-P4
- IDPU-P5 to BOOM-P4
- IDPU-P6 to BOOM-P5
- IDPU-P7 to BOOM-P6
-
- Boom Harness:
 - BOOM-J5 to MAG-J1,
 - BOOM-J1, J2, J4 to SWEA-P1
- SWEA-P3 enable plug(s)

GSFC/Acuna is responsible for the pig-tail on MAG to MAG-P1

Caltech & UCB (Caltech defines & provides connectors; UCB to build - TBR) are responsible for:

- SEPTNS-P1 and SEPTNS-P2 to SEP-P7
 - SEPTE-P1 and SEPTE-P2 to SEP-P9
 - SEP-P5 to SIT-P1

UMd is responsible for the SIT-P2 disable plug/test access harness