

# STEREO *IMPACT*

## Harness Specification

IMPACTHarnessSpec\_E.doc  
Version E – 2002-Nov-26

---

David Curtis, UCB IMPACT Project Manager

## Document Revision Record

Rev.	Date	Description of Change	Approved By
A	2001-Mar-16	Preliminary Draft	-
B	2001-Mar-20	<ul style="list-style-type: none"> <li>• Add harness responsibilities</li> <li>• Add details of spacecraft harness</li> <li>• Minor fixes</li> </ul>	-
C	2001-Aug-1	<ul style="list-style-type: none"> <li>• Change power from TP to TSQ</li> <li>• Add BOOM temp sensor to BOOM-P2</li> <li>• Split STE, SEPT-E, SIT</li> </ul>	-
D	2001-Sep-26	<ul style="list-style-type: none"> <li>• Move SEPT and SIT actuator connector from SEP Central</li> <li>• Change IDPU-J2 to two twinax</li> <li>• Split STE into STE-U, STE-D</li> <li>• Add SEP mating connector info in sections 3.5 to 3.10</li> <li>• Add SEP subsystem connector pinouts in sections 4.5.2 to 4.10.1</li> <li>• Change SEP S/C thermal con. type/size</li> </ul>	-
E	2002-Nov-26	<ul style="list-style-type: none"> <li>• Change to GSFC connector specifications for D connectors</li> <li>• Replace SWEA-J1 &amp; -J3 with MDM connectors</li> <li>• Remove SWEA-J2 (internal)</li> <li>• Update SWEA connector pin-outs</li> <li>• Some connectors become internal (HET, LET, STE)</li> <li>• SEPT connectors combined at SEP end</li> <li>• Update SEPT connector pinouts.</li> <li>• Modify MAG connector pinouts</li> </ul>	

## **Distribution List**

Dave Curtis, UCB

Peter Berg, UCB

Robert Ulrich, UCB

Steve McBride, UCB

Andy Driesman, APL

Mario Acuna, GSFC (MAG)

Tycho von Roseninge, GSFC (SEP)

Alan Cummings, Caltech (SEP)

Reinhold Mueller-Mellin, Kiel (SEPT)

Peter Walpole, UMd (SIT)

Steven Turco, UNH (PLASTIC)

## Table of Contents

<b>Document Revision Record</b> .....	<b>i</b>
<b>Distribution List</b> .....	<b>ii</b>
<b>1. Introduction</b> .....	<b>1</b>
1.1. <i>Document Conventions</i> .....	<i>1</i>
1.2. <i>Applicable Documents</i> .....	<i>1</i>
<b>2. Harness Figures</b> .....	<b>1</b>
<b>3. Connector Types</b> .....	<b>4</b>
3.1. <i>IDPU Connectors</i> .....	<i>4</i>
3.2. <i>Boom Connectors</i> .....	<i>4</i>
3.3. <i>SWEA Connectors</i> .....	<i>5</i>
3.4. <i>MAG Connector</i> .....	<i>5</i>
3.5. <i>SEP Connectors</i> .....	<i>5</i>
3.6. <i>SEPT-E Connectors</i> .....	<i>6</i>
3.7. <i>SEPT-NS Connectors</i> .....	<i>6</i>
3.8. <i>SIT Connectors</i> .....	<i>6</i>
<b>4. Connector Pinouts</b> .....	<b>7</b>
4.1. <i>IDPU Connectors</i> .....	<i>7</i>
4.1.1. IDPU-P1 (IDPU Power).....	7
4.1.2. IDPU-J2 (1553 Interface to Spacecraft).....	8
4.1.3. IDPU-P3 (IDPU to PLASTIC).....	8
4.1.4. IDPU-P4 (IDPU to SEP).....	9
4.1.5. IDPU-P5 (IDPU to SWEA/STE).....	9
4.1.6. IDPU-P6 (IDPU to MAG).....	10
4.1.7. IDPU-P7 (IDPU to STE-U).....	11
4.2. <i>Boom Connectors</i> .....	<i>12</i>
4.2.1. BOOM-P1 (SWEA/STE Power).....	12
4.2.2. BOOM-P2 (SWEA S/C Temp Sensor).....	12
4.2.3. BOOM-P3 (Boom Actuator Power).....	13
4.2.4. BOOM-P4 (SWEA/STE to IDPU).....	13
4.2.5. BOOM-P5 (IDPU to MAG).....	14
4.2.6. BOOM-P6 (IDPU to STE-U).....	15
4.3. <i>Internal Boom Harness</i> .....	<i>16</i>
4.3.1. BOOM-J1 (SWEA/STE Power).....	16
4.3.2. BOOM-J2 (SWEA S/C Temp Sensor).....	16
4.3.3. BOOM-J4 (SWEA/STE to IDPU).....	17
4.3.4. BOOM-J5 (IDPU to MAG).....	17
4.3.5. BOOM-J6 (IDPU to STE-U).....	18
4.3.6. SWEA-P1 (IDPU to SWEA).....	19
4.3.7. MAG-J1 (IDPU to MAG).....	20
4.4. <i>SWEA Connectors</i> .....	<i>21</i>
4.4.1. SWEA-P1 (IDPU to SWEA).....	21
4.4.2. SWEA-P3 (HV/Actuator Enable).....	21
4.5. <i>SEP Connectors</i> .....	<i>22</i>
4.5.1. SEP-P1 (SEP Power).....	22
4.5.2. SEP-P2 (SEP S/C Temp. Sensors).....	22

4.5.3.	SEP-P3 (SIT & SEPT Cover Actuators).....	23
4.5.4.	SEP-P4 (SEP to IDPU) .....	23
4.5.5.	SEP-P5 (SEP to SIT) .....	24
4.5.6.	SEP-P6 (SEP to SEPT-NS).....	26
4.5.7.	SEP-P7 (SEP to SEPT-NS).....	26
4.5.8.	SEP-P8 (SEP to SEPT-E) .....	27
4.5.9.	SEP-P9 (SEP to SEPT-E) .....	27
4.6.	<b><i>SEPT-E Connectors</i></b> .....	<b>28</b>
4.6.1.	SEPTE-P1 (SEP to SEPT-E) .....	28
4.6.2.	SEPTE-P2 (SEP to SEPT-E) .....	28
4.6.3.	SEPTE-P3 (S/C to SEPT-E) .....	30
4.7.	<b><i>SEPT-NS Connectors</i></b> .....	<b>31</b>
4.7.1.	SEPTNS-P1 (SEP to SEPT-NS).....	31
4.7.2.	SEPTNS-P2 (SEP to SEPT-NS).....	31
4.7.3.	SEPTNS-P3 (S/C to SEPT-NS).....	32
4.8.	<b><i>SIT Connectors</i></b> .....	<b>33</b>
4.8.1.	SIT-P1 (SEP to SIT) .....	33
4.8.2.	SIT-P2 (SIT HV Disable/Test) .....	34
4.8.3.	SIT-P3 (S/C to SIT) .....	34
5.	<b>Harness Responsibilities</b> .....	<b>35</b>

## 1. Introduction

This specification describes the harnesses between the various parts of the IMPACT instrument suite, as well as the interface connectors to the spacecraft. The spec covers the connector types and pinouts as well as the harness wiring details.

### 1.1. *Document Conventions*

In this document, **TBD** (To Be Determined) means that no data currently exists. A value followed by **TBR** (To Be Resolved) means that this value is preliminary. In either case, the value is typically followed by a code such as UCB indicating who is responsible for providing the data, and a unique reference number.

### 1.2. *Applicable Documents*

The following documents include drawings and STEREO Project policies. All documents and drawings can be found on the Berkeley STEREO/IMPACT FTP site:

<http://sprg.ssl.berkeley.edu/impact/dwc/>

1. IMPACT/Spacecraft ICD (on APL web site)
2. ICD/Impact Serial Interface

## 2. Harness Figures

Figure 2-1 is a schematic of the STEREO IMPACT harness indicating the connector designations, where they are, and what they connect to. [Figure 2-2 shows the SEP harnessing, showing some internal details.](#)

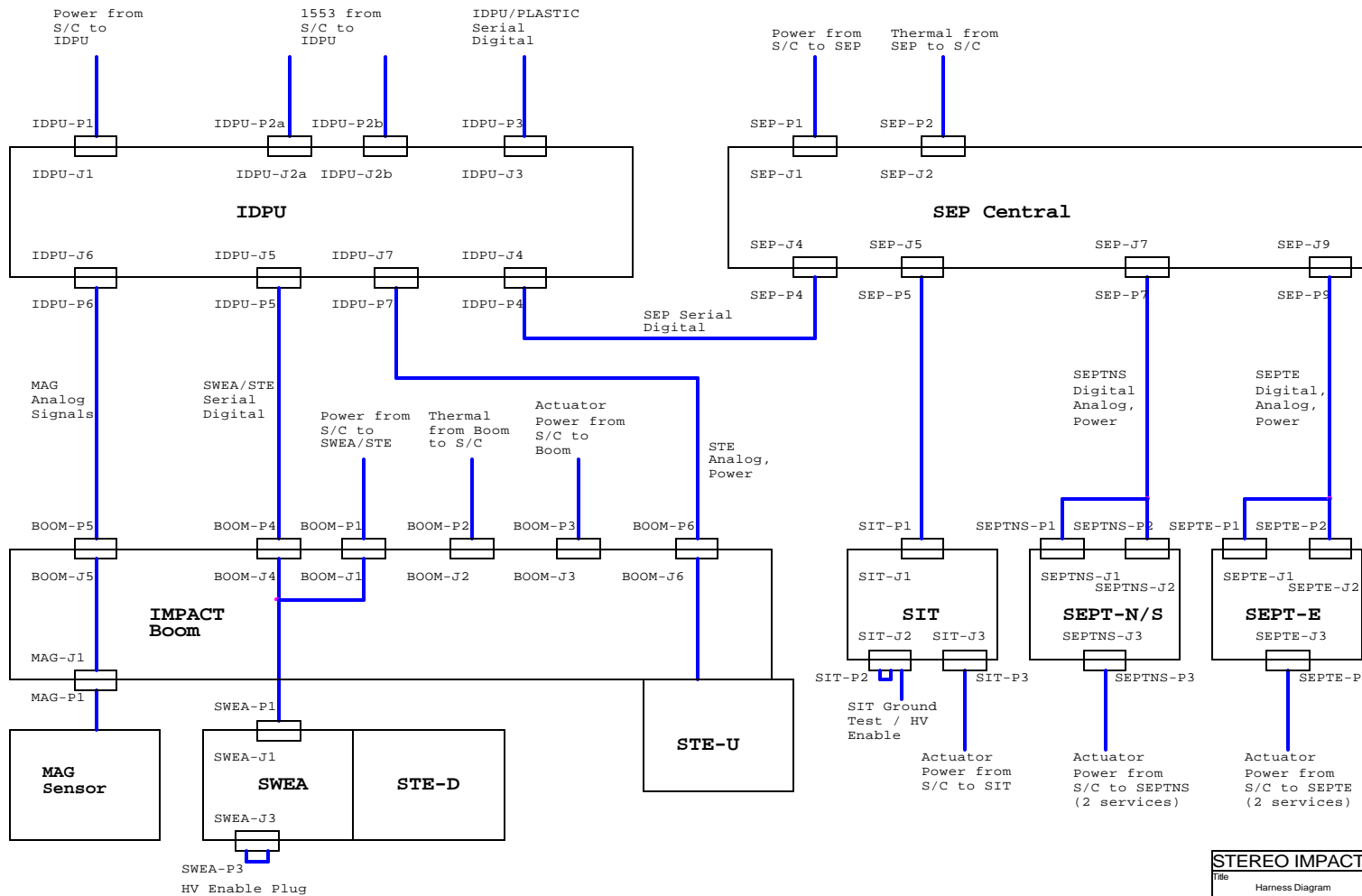

<b>STEREO IMPACT</b>		University of California, Space Science Lab
Title	Harness Diagram	
Size	Document Number	Rev
B	IMPACT_HARNESS	E
Date:	Thursday, October 31, 2002	Sheet 1 of 1

Figure 2-1 - IMPACT Harness Schematic

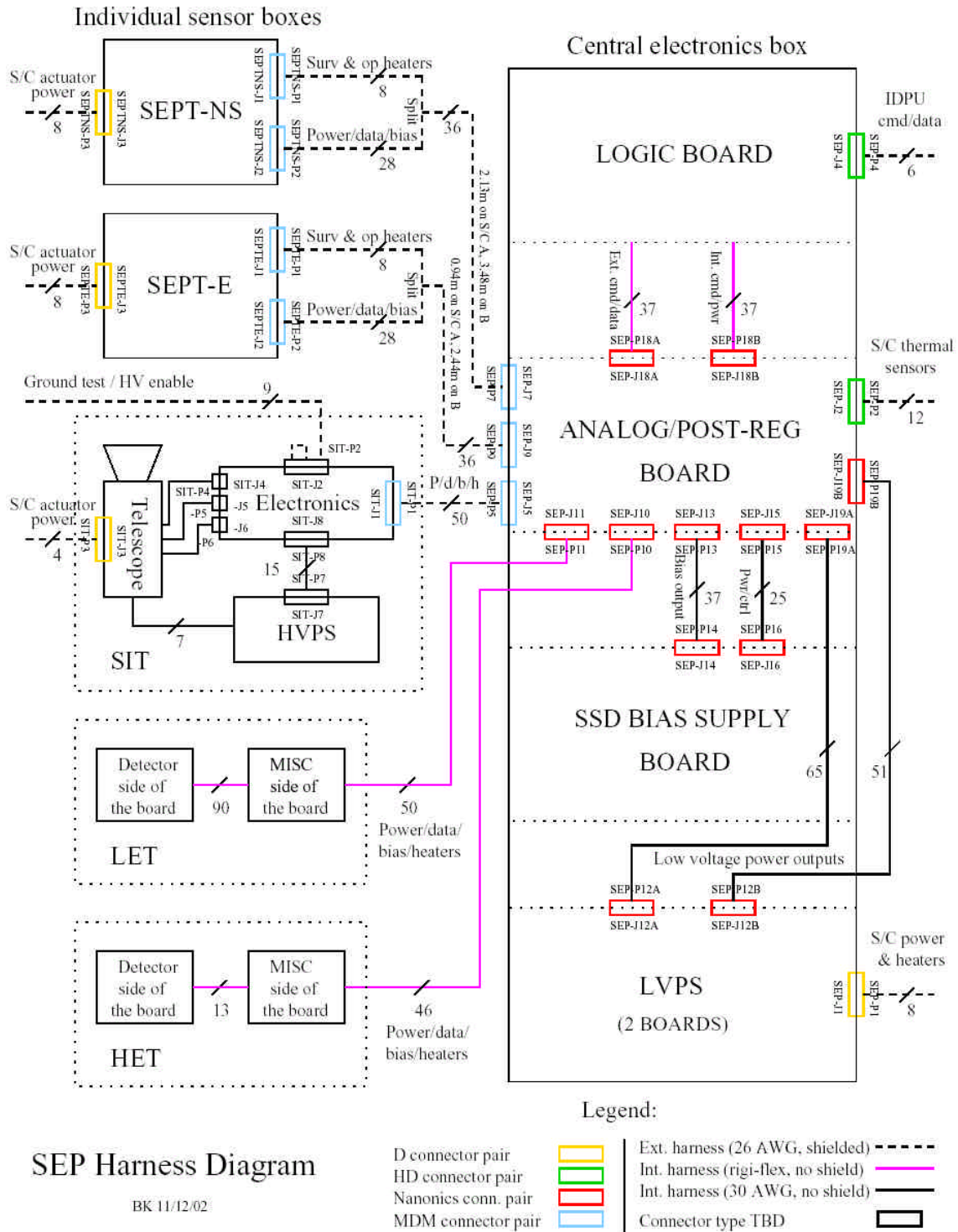

Figure 2-2 SEP Harness



### 3. Connector Types

The instrument harness connectors are described below. "D" connectors are standard density, "HD" are High Density D-type Connectors. "MDM" are MDM D connectors. Note that these are the HARNESS connectors, not the box connectors. Harness connectors are designated by the box they attach to (such as IPC), followed by -Pn (where n is the connector number on that box), while box connectors designators are identical except they are followed by -Jn.

#### 3.1. IDPU Connectors

Name	Use	Type	Part Number	Mating Connector
IDPU-P1	IDPU Power from Spacecraft	D15S	TBD-APL001	GSFC 311P409-2P-B-12
IDPU-P2a	1553 A Interface from Spacecraft	Twinax	Sabritec 015028-2000	Sabritec 015100-5001
IDPU-P2b	1553 B Interface from Spacecraft	Twinax	Sabritec 015028-2000	Sabritec 015100-5001
IDPU-P3	IDPU to PLASTIC Interface	HD15S	GSFC 311P407-1S-B-12	GSFC 311P407-1P-B-12
IDPU-P4	IDPU to SEP Interface	HD15S	GSFC 311P407-1S-B-12	GSFC 311P407-1P-B-12
IDPU-P5	IDPU to SWEA/STE Interface	HD15S	GSFC 311P407-1S-B-12	GSFC 311P407-1P-B-12
IDPU-P6	IDPU to MAG Interface	HD15P	GSFC 311P407-1P-B-12	TBD-MAG-001
IDPU-P7	IDPU to STE-U Interface	HD26P	GSFC 311P407-2P-B-12	GSFC 311P407-2S-B-12

#### 3.2. Boom Connectors

Name	Use	Type	Part Number	Mating Connector
BOOM-P1	SWEA/STE Power from Spacecraft	D15S	TBD-APL001	GSFC 311P409-2P-B-12
BOOM-P2	Temp Sensor Interface to Spacecraft	D9P	TBD-APL001	GSFC 311P409-1S-B-12
BOOM-P3	Boom Actuator Power from Spacecraft	D9S	TBD-APL001	GSFC 311P409-1P-B-12
BOOM-P4	IDPU to SWEA/STE Interface	HD15P	GSFC 311P407-1P-B-12	GSFC 311P407-1S-B-12
BOOM-P5	IDPU to MAG Interface	HD15S	GSFC 311P407-1S-B-12	GSFC 311P407-1P-B-12
BOOM-P6	IDPU to STE-U Interface	HD26S	GSFC 311P407-2S-B-12	GSFC 311P407-2P-B-12

**3.3. SWEA Connectors**

Name	Use	Type	Part Number	Mating Connector
SWEA-P1	SWEA/STE Interface (Signal+Power+Temp)	MDM15R	M83513/04-B11N	Airborn MK-232-015-125-2200
SWEA-P3	Enable Plug	MDM15R	M83513/04-B11N	M83513/04-B11NP

**3.4. MAG Connector**

Name	Use	Type	Part Number	Mating Connector
MAG-P1	MAG Sensor Pigtail Connector	HD15P	TBD-MAG001	GSFC 311P407-1S-B-12

**3.5. SEP Connectors**

Name	Use	Type	Part Number	Mating Connector
SEP-P1	SEP Power from Spacecraft	D15S	TBD-APL001	GSFC 311P409-2P-B-12
SEP-P2	SEP Temp Sensor Interface to Spacecraft	HD15S	TBD-APL001	GSFC 311P407-1P-B-12
SEP-P4	IDPU to SEP Interface	HD15P	M24308/7-373	GSFC 311P407-1S-B-12
SEP-P5	SEP to SIT Interface	MDM51S	MWDM2L-51S-6J5-7M-429A	MWDM2L-51PCBRP-.110-429A
SEP-P7	SEP to SEPT-NS Dig/Ana/Pwr Interface	MDM37S	MWDM2L-37S-6J5-xxM-429A	MWDM2L-37PCBRP-.110-429A
SEP-P9	SEP to SEPT-E Dig/Ana/Pwr Interface	MDM37S	MWDM2L-37S-6J5-xxM-429A	MWDM2L-37PCBRP-.110-429A

**3.6. SEPT-E Connectors**

Name	Use	Type	Part Number	Mating Connector
SEPT-E-P1	SEP to SEPT-E Heater Interface	MDM9P	MWDM2L-9P-6J5-12M-429A	MWDM2L-9S-6J5-12M-429A
SEPT-E-P2	SEP to SEPT-E Dig/Ana/Pwr Interface	MDM31P	MWDM2L-31P-6J5-12M-429A	MWDM2L-31SCBRP-.110-429A
SEPT-E-P3	Spacecraft to SEPT-E Actuator Power	D9S	TBD-APL-001	GSFC 311P409-1P-B-12

**3.7. SEPT-NS Connectors**

Name	Use	Type	Part Number	Mating Connector
SEPT-NS-P1	SEP to SEPT-NS Heater Interface	MDM9P	MWDM2L-9P-6J5-12M-429A	MWDM2L-9S-6J5-12M-429A
SEPT-NS-P2	SEP to SEPT-NS Dig/Ana/Pwr Interface	MDM31P	MWDM2L-31P-6J5-12M-429A	MWDM2L-31SCBRP-.110-429A
SEPT-NS-P3	Spacecraft to SEPT-NS Actuator Power	D9S	TBD-APL-001	GSFC 311P409-1P-B-12

**3.8. SIT Connectors**

Name	Use	Type	Part Number	Mating Connector
SIT-P1	SEP to SIT Interface	MDM51P	MWDM2L-51P-6J5-12M-429A	MWDM2L-51SCBRP-.110-429A
SIT-P2	SIT HV Disable Plug / Test Interface	TBD-SIT-002	TBD-SEP-001	TBD-SEP-001
SIT-P3	Spacecraft to SIT Actuator Power	D9S	TBD-APL-001	GSFC 311P409-1P-B-12

## 4. Connector Pinouts

In the following tables:

- TSPN is a twisted-shielded pair with shield not connected (at this end).
- TSPS is a twisted shielded pair with shield terminated on the connector backshell.
- TSP is a twisted shielded pair with the shield connected to a pin.
- TP is a twisted pair, no shield or jacket (just two wires twisted together).
- TT is a twisted triple
- T5 is a twisted 5-wire group
- TSQ is a twisted shielded quad (shield terminated at backshell)
- Coax is an RG178 (**TBR-UCB-002**) coax
- TA is 77 ohm twinax used for the 1553 harness, type M17/176-00002

All harnesses will have a common over-shield connected to chassis ground at both ends **via the connector shell and mounting hardware** except where otherwise noted. **Chassis ground pin on connectors is normally not connected in the harness.**

### 4.1. IDPU Connectors

#### 4.1.1. IDPU-P1 (IDPU Power)

Pin	Signal	Destination	Harness
1	Spare		
2	+28V Primary	Spacecraft	#22 TSQ w/3,10,11
3	+28V Redundant	Spacecraft	#22 TSQ w/2,10,11
4	Spare		
5	+28V Heater Primary	Spacecraft	#22 TSQ w/6,13,14
6	+28V Heater Redundant	Spacecraft	#22 TSQ w/5,13,14
7	Spare		
8	Chassis (connected in IDPU to IDPU chassis)		
9	Spare		
10	+28V Return Primary	Spacecraft	#22 TSQ w/2,3,11
11	+28V Return Redundant	Spacecraft	#22 TSQ w/2,3,10
12	Spare		
13	+28V Heater Return Primary	Spacecraft	#22 TSQ w/5,6,14
14	+28V Heater Return Redundant	Spacecraft	#22 TSQ w/5,6,13
15	Spare		

## 4.1.2. IDPU-J2 (1553 Interface to Spacecraft)

IDPU-J2a

Pin	Signal	Destination	Harness
1	1553_A_P	Spacecraft	TA-blue
2	1553_A_N (Inner shield)	Spacecraft	TA-white
3	Outer Shield	Spacecraft	TA-Shield

IDPU-J2b

Pin	Signal	Destination	Harness
1	1553_B_P	Spacecraft	TA-blue
2	1553_B_N (Inner shield)	Spacecraft	TA-white
3	Outer Shield	Spacecraft	TA-Shield

## 4.1.3. IDPU-P3 (IDPU to PLASTIC)

Pin	Signal	Destination	Harness
1	CLK	TBD-UNH-002	Coax w/2
2	CLK-RET	TBD-UNH-002	Coax Shield w/1
3	Spare		
4	Spare		
5	Spare		
6	CMD	TBD-UNH-002	Coax w/7
7	CMD-RET	TBD-UNH-002	Coax Shield w/6
8	Spare		
9	Spare		
10	Spare		
11	TLM	TBD-UNH-002	Coax w/12
12	TLM-RET	TBD-UNH-002	Coax Shield w/11
13	Spare		
14	Spare		
15	Chassis (connected in IDPU to IDPU chassis)		

## 4.1.4. IDPU-P4 (IDPU to SEP)

Pin	Signal	Destination	Harness
1	CLK	SEP-P4 pin 1	Coax w/2
2	CLK-RET	SEP-P4 pin 2	Coax Shield w/1
3	Spare		
4	Spare		
5	Spare		
6	CMD	SEP-P4 pin 6	Coax w/7
7	CMD-RET	SEP-P4 pin 7	Coax Shield w/6
8	Spare		
9	Spare		
10	Spare		
11	TLM	SEP-P4 pin 11	Coax w/12
12	TLM-RET	SEP-P4 pin 12	Coax Shield w/11
13	Spare		
14	Spare		
15	Chassis (connected in IDPU to IDPU chassis)		

(Note: This is a 1:1 harness)

## 4.1.5. IDPU-P5 (IDPU to SWEA/STE)

Pin	Signal	Destination	Harness
1	CLK	BOOM-P4 pin 1	Coax w/2
2	CLK-RET	BOOM-P4 pin 2	Coax Shield w/1
3	Spare		
4	Spare		
5	Spare		
6	CMD	BOOM-P4 pin 6	Coax w/7
7	CMD-RET	BOOM-P4 pin 7	Coax Shield w/6
8	Spare		
9	Spare		
10	Spare		
11	TLM	BOOM-P4 pin 11	Coax w/12
12	TLM-RET	BOOM-P4 pin 12	Coax Shield w/11
13	Spare		
14	Spare		
15	Chassis (connected in IDPU to IDPU chassis)		

(Note: This is a 1:1 harness)

## 4.1.6. IDPU-P6 (IDPU to MAG)

Pin	Signal	Destination	Harness
1	XYZ Drive	BOOM-P5 pin 1	Coax w/9
2	X Sensor Sig	BOOM-P5 pin 2	Coax w/10
3	Y Sensor Sig	BOOM-P5 pin 3	Coax w/11
4	Z Sensor Sig	BOOM-P5 pin 4	Coax w/12
5	MAG Temp Sensor	BOOM-P5 pin 5	#26 TSP w/13,14
6	MAG Heater	BOOM-P5 pin 6	#26 TSP w/7,8
7	MAG Heater RET	BOOM-P5 pin 7	#26 TSP w/6,8
8	MAG Heater Shield	BOOM-P5 pin 8	#26 TSP Shield
9	XYZ Drive RET, T2 Ret	BOOM-P5 pin 9	Coax Shield w/1
10	X Sensor Sig RET	BOOM-P5 pin 10	Coax Shield w/2
11	Y Sensor Sig RET	BOOM-P5 pin 11	Coax Shield w/3
12	Z Sensor Sig RET	BOOM-P5 pin 12	Coax Shield w/4
13	MAG Temp Sensor RET	BOOM-P5 pin 13	#26 TSP w/5,14
14	MAG Temp Sensor Shield, T2	BOOM-P5 pin 14	#26 TSP Shield
15	Chassis (connected in IDPU to IDPU chassis)		

(Note: This is a 1:1 harness)

## 4.1.7. IDPU-P7 (IDPU to STE-U)

Pin	Signal	Destination	Harness
1	OUTPUT1	BOOM-P6 pin 1	Coax w/2
2	OUTPUT RET	BOOM-P6 pin 2	Coax Shield w/1
3	OUTPUT2	BOOM-P6 pin 3	Coax w/4
4	OUTPUT RET	BOOM-P6 pin 4	Coax Shield w/3
5	OUTPUT3	BOOM-P6 pin 5	Coax w/6
6	OUTPUT RET	BOOM-P6 pin 6	Coax Shield w/5
7	OUTPUT4	BOOM-P6 pin 7	Coax w/8
8	OUTPUT RET	BOOM-P6 pin 8	Coax Shield w/7
9	Spare		
10	Test RET	BOOM-P6 pin 10	Coax Shield w/11
11	Test	BOOM-P6 pin 11	Coax w/10
12	Ground	BOOM-P6 pin 12	#26 TT w/13,14
13	+5V	BOOM-P6 pin 13	#26 TT w/12,14
14	-5V	BOOM-P6 pin 14	#26 TT w/12,13
15	Bias	BOOM-P6 pin 15	#26
16	-12V (TBR-UCB-004)	BOOM-P6 pin 16	#26
17	Spare		
18	Spare		
19	Door Close Act.	BOOM-P6 pin 19	#26 TT w/20,21
20	Door Open Act.	BOOM-P6 pin 20	#26 TT w/19,21
21	Door Act. RET	BOOM-P6 pin 21	#26 TT w/19,20
22	Spare		
23	Spare		
24	STE Temp	BOOM-P6 pin 24	#26 TP w/25
25	STE Temp RET	BOOM-P6 pin 25	#26 TP w/24
26	Chassis (connected in IDPU to IDPU chassis)		

(Note: This is a 1:1 harness)



## 4.2. Boom Connectors

### 4.2.1. BOOM-P1 (SWEA/STE Power)

Pin	Signal	Destination	Harness
1	Spare		
2	+28V Primary	Spacecraft	#22 TSQ w/3,10,11
3	+28V Redundant	Spacecraft	#22 TSQ w/2,10,11
4	+28V Boom Deployment Heater Primary	Spacecraft	#22 TSQ w/7,12,15
5	+28V Heater Primary	Spacecraft	#22 TSQ w/6,13,14
6	+28V Heater Redundant	Spacecraft	#22 TSQ w/5,13,14
7	+28V Boom Deployment Heater Redundant	Spacecraft	#22 TSQ w/4,12,15
8	Chassis (connected in BOOM to BOOM chassis)		
9	Spare		
10	+28V Return Primary	Spacecraft	#22 TSQ w/2,3,11
11	+28V Return Redundant	Spacecraft	#22 TSQ w/2,3,10
12	+28V Boom Deployment Heater Return Primary	Spacecraft	#22 TSQ w/4,7,15
13	+28V Heater Return Primary	Spacecraft	#22 TSQ w/5,6,14
14	+28V Heater Return Redundant	Spacecraft	#22 TSQ w/5,6,13
15	+28V Boom Deployment Heater Return Redundant	Spacecraft	#22 TSQ w/4,7,12

### 4.2.2. BOOM-P2 (SWEA S/C Temp Sensor)

Pin	Signal	Destination	Harness
1	SWEA Temp Sensor	Spacecraft	
2	BOOM Temp Sensor	Spacecraft	
3	STE-U Temp Sensor	Spacecraft	
4	Spare		
5	Spare		
6	SWEA Temp Sensor RET	Spacecraft	
7	BOOM Temp Sensor RET	Spacecraft	
8	STE-U Temp Sensor RET	Spacecraft	
9	Chassis (connected in BOOM to BOOM chassis)		

## 4.2.3. BOOM-P3 (Boom Actuator Power)

Pin	Signal	Destination	Harness
1	BOOM Release	Spacecraft	#22 TSQ
2	BOOM Release	Spacecraft	#22 TSQ
3	Spare		
4	Spare		
5	Spare		
6	BOOM Release RET	Spacecraft	#22 TSQ
7	BOOM Release RET	Spacecraft	#22 TSQ
8	Spare		
9	Shield Ground (Connected in BOOM to BOOM chassis)		

## 4.2.4. BOOM-P4 (SWEA/STE to IDPU)

Pin	Signal	Destination	Harness
1	CLK	IDPU-P5 pin 1	Coax w/2
2	CLK-RET	IDPU-P5 pin 2	Coax Shield w/1
3	Spare		
4	Spare		
5	Spare		
6	CMD	IDPU-P5 pin 6	Coax w/7
7	CMD-RET	IDPU-P5 pin 7	Coax Shield w/6
8	Spare		
9	Spare		
10	Spare		
11	TLM	IDPU-P5 pin 11	Coax w/12
12	TLM-RET	IDPU-P5 pin 12	Coax Shield w/11
13	Spare		
14	Spare		
15	Chassis (connected in BOOM to BOOM chassis)		

(Note: This is a 1:1 harness)

## 4.2.5. BOOM-P5 (IDPU to MAG)

Pin	Signal	Destination	Harness
1	XYZ Drive	IDPU-P6 pin 1	Coax w/9
2	X Sensor Sig	IDPU-P6 pin 2	Coax w/10
3	Y Sensor Sig	IDPU-P6 pin 3	Coax w/11
4	Z Sensor Sig	IDPU-P6 pin 4	Coax w/12
5	MAG Temp Sensor	IDPU-P6 pin 5	#26 TSP w/13,14
6	MAG Heater	IDPU-P6 pin 6	#26 TSP w/7,8
7	MAG Heater RET	IDPU-P6 pin 7	#26 TSP w/6,8
8	MAG Heater Shield	IDPU-P6 pin 8	#26 TSP Shield
9	XYZ Drive RET, T2 Ret	IDPU-P6 pin 9	Coax Shield w/1
10	X Sensor Sig RET	IDPU-P6 pin 10	Coax Shield w/2
11	Y Sensor Sig RET	IDPU-P6 pin 11	Coax Shield w/3
12	Z Sensor Sig RET	IDPU-P6 pin 12	Coax Shield w/4
13	MAG Temp Sensor RET	IDPU-P6 pin 13	#26 TSP w/5,14
14	MAG Temp Sensor Shield, T2	IDPU-P6 pin 14	#26 TSP Shield
15	Chassis (connected in BOOM to BOOM chassis)		

(Note: This is a 1:1 harness)

## 4.2.6. BOOM-P6 (IDPU to STE-U)

Pin	Signal	Destination	Harness
1	OUTPUT1	IDPU-P7 pin 1	Coax w/2
2	OUTPUT RET	IDPU-P7 pin 2	Coax Shield w/1
3	OUTPUT2	IDPU-P7 pin 3	Coax w/4
4	OUTPUT RET	IDPU-P7 pin 4	Coax Shield w/3
5	OUTPUT3	IDPU-P7 pin 5	Coax w/6
6	OUTPUT RET	IDPU-P7 pin 6	Coax Shield w/5
7	OUTPUT4	IDPU-P7 pin 7	Coax w/8
8	OUTPUT RET	IDPU-P7 pin 8	Coax Shield w/7
9	Spare		
10	Test RET	IDPU-P7 pin 10	Coax Shield w/11
11	Test	IDPU-P7 pin 11	Coax w/10
12	Ground	IDPU-P7 pin 12	#26 TT w/13,14
13	+5V	IDPU-P7 pin 13	#26 TT w/12,14
14	-5V	IDPU-P7 pin 14	#26 TT w/12,13
15	Bias	IDPU-P7 pin 15	#26
16	-12V (TBR-UCB-004)	IDPU-P7 pin 16	#26
17	Spare		
18	Spare		
19	Door Close Act.	IDPU-P7 pin 19	#26 TT w/20,21
20	Door Open Act.	IDPU-P7 pin 20	#26 TT w/19,21
21	Door Act. RET	IDPU-P7 pin 21	#26 TT w/19,20
22	Spare		
23	Spare		
24	STE Temp	IDPU-P7 pin 24	#26 TP w/25
25	STE Temp RET	IDPU-P7 pin 25	#26 TP w/24
26	Chassis (connected in IDPU to IDPU chassis)		

(Note: This is a 1:1 harness)

### 4.3. Internal Boom Harness

#### 4.3.1. BOOM-J1 (SWEA/STE Power)

Pin	Signal	Destination	Harness
1	Spare		
2	+28V Primary	SWEA-P1 pin 8	#26 TSP w/5
3	+28V Redundant	SWEA-P1 pin 8	#26 TSP w/5
4	+28V Boom Deployment Heater Primary	Deployment heater	
5	+28V Heater Primary	SWEA-P1 pin 7	#26 TSP w/2
6	+28V Heater Redundant	SWEA-P1 pin 7	#26 TSP w/2
7	+28V Boom Deployment Heater Redundant	Deployment heater	
8	Chassis (connected in BOOM to BOOM chassis)		
9	Spare		
10	+28V Return Primary	SWEA-P1 pin 14	#26 TSP w/13
11	+28V Return Redundant	SWEA-P1 pin 14	#26 TSP w/13
12	+28V Boom Deployment Heater Return Primary	Deployment heater	
13	+28V Heater Return Primary	SWEA-P1 pin 15	#26 TSP w/10
14	+28V Heater Return Redundant	SWEA-P1 pin 15	#26 TSP w/10
15	+28V Boom Deployment Heater Return Redundant	Deployment heater	

Note primary and redundant power connected at BOOM-J1, with a single TP up the boom. Terminate internal shields on TSP to chassis/backshell.

#### 4.3.2. BOOM-J2 (SWEA S/C Temp Sensor)

Pin	Signal	Destination	Harness
1	SWEA Temp Sensor	SWEA-P1 pin 4	#26 TSP w/6
2	BOOM Temp Sensor	Boom	#26 TP w/7
3	STE-U Temp Sensor	STE-U	#26 TP w/8
4	Spare		
5	Spare		
6	SWEA Temp Sensor RET	SWEA-P1 pin 5	#26 TSP w/1
7	BOOM Temp Sensor RET	Boom	#26 TP w/2
8	STE-U Temp Sensor	STE-U	#26 TP w/3
9	Chassis (connected in BOOM to BOOM chassis)	Boom Chassis	

Terminate internal shield on TSP to chassis/backshell

## 4.3.3. BOOM-J4 (SWEA/STE to IDPU)

Pin	Signal	Destination	Harness
1	CLK	SWEA-P1 pin 1	Coax w/2
2	CLK-RET	SWEA-P1 pin 2	Coax Shield w/1
3	Spare		
4	Spare		
5	Spare		
6	CMD	SWEA-P1 pin 6	Coax w/7
7	CMD-RET	SWEA-P1 pin 7	Coax Shield w/6
8	Spare		
9	Spare		
10	Spare		
11	TLM	SWEA-P1 pin 11	Coax w/12
12	TLM-RET	SWEA-P1 pin 12	Coax Shield w/11
13	Spare		
14	Spare		
15	Chassis (connected in BOOM to BOOM chassis)		

(Note: This is a 1:1 harness)

## 4.3.4. BOOM-J5 (IDPU to MAG)

Pin	Signal	Destination	Harness
1	XYZ Drive	MAG-J1 pin 1	Coax w/9
2	X Sensor Sig	MAG-J1 pin 2	Coax w/10
3	Y Sensor Sig	MAG-J1 pin 3	Coax w/11
4	Z Sensor Sig	MAG-J1 pin 4	Coax w/12
5	MAG Temp Sensor	MAG-J1 pin 5	#26 TSP w/13,14
6	MAG Heater	MAG-J1 pin 6	#26 TSP w/7,8
7	MAG Heater RET	MAG-J1 pin 7	#26 TSP w/6,8
8	MAG Heater Shield	MAG-J1 pin 8	#26 TSP Shield
9	XYZ Drive RET, T2 Ret	MAG-J1 pin 9	Coax Shield w/1
10	X Sensor Sig RET	MAG-J1 pin 10	Coax Shield w/2
11	Y Sensor Sig RET	MAG-J1 pin 11	Coax Shield w/3
12	Z Sensor Sig RET	MAG-J1 pin 12	Coax Shield w/4
13	MAG Temp Sensor RET	MAG-J1 pin 13	#26 TSP w/5,14
14	MAG Temp Sensor Shield, T2	MAG-J1 pin 14	#26 TSP Shield
15	Chassis (connected in BOOM to BOOM chassis)		

(Note: This is a 1:1 harness)

## 4.3.5. BOOM-J6 (IDPU to STE-U)

Pin	Signal	Destination	Harness
1	OUTPUT1	STE-U	Coax w/2
2	OUTPUT RET	STE-U	Coax Shield w/1
3	OUTPUT2	STE-U	Coax w/4
4	OUTPUT RET	STE-U	Coax Shield w/3
5	OUTPUT3		Coax w/6
6	OUTPUT RET		Coax Shield w/5
7	OUTPUT4		Coax w/8
8	OUTPUT RET		Coax Shield w/7
9	Spare	STE-U	
10	Test RET	STE-U	Coax Shield w/11
11	Test		Coax w/10
12	Ground	STE-U	#26 TT w/13,14
13	+5V	STE-U	#26 TT w/12,14
14	-5V	STE-U	#26 TT w/12,13
15	Bias	STE-U	#26
16	-12V (TBR-UCB-004)	STE-U	#26
17	Spare	STE-U	
18	Spare	STE-U	
19	Door Close Act.	STE-U	#26 TT w/20,21
20	Door Open Act.	STE-U	#26 TT w/19,21
21	Door Act. RET	STE-U	#26 TT w/19,20
22	Spare		
23	Spare		
24	STE Temp	STE-U	#26 TP w/25
25	STE Temp RET	STE-U	#26 TP w/24
26	Chassis (connected to chassis)		

Note: BOOM-J6 is connected to the STE-U pig-tail.

## 4.3.6. SWEA-P1 (IDPU to SWEA)

Pin	Signal	Destination	Harness
1	Chassis (connected in SWEA to SWEA chassis)		TSP shields
2	TLM-RET	BOOM-J4 pin 12	Coax Shield w/9
3	SWEA Temp.	BOOM-J2 pin 1	#26 TSP w/5
4	CMD-RET	BOOM-J4 pin 7	Coax Shield w/10
5	SWEA Temp. RET	BOOM-J2 pin 6	#26 TSP w/3
6	CLK-RET	BOOM-J4 pin 2	Coax Shield w/11
7	+28V Heater	BOOM-J1 pin 5	#26 TSP w/15
8	+28V	BOOM-J1 pin 2	#26 TSP w/14
9	TLM	BOOM-J4 pin 11	Coax w/2
10	CMD	BOOM-J4 pin 6	Coax w/4
11	CLK	BOOM-J4 pin 1	Coax w/6
12	Spare		
13	Spare		
14	+28V RET	BOOM-J1 pin 10	#26 TSP w/8
15	+28V Heater RET	BOOM-J1 pin 13	#26 TSP w/7



## 4.3.7. MAG-J1 (IDPU to MAG)

Pin	Signal	Destination	Harness
1	XYZ Drive	BOOM-J5 pin 1	Coax w/9
2	X Sensor Sig	BOOM-J5 pin 2	Coax w/10
3	Y Sensor Sig	BOOM-J5 pin 3	Coax w/11
4	Z Sensor Sig	BOOM-J5 pin 4	Coax w/12
5	MAG Temp Sensor	BOOM-J5 pin 5	#26 TSP w/13,14
6	MAG Heater	BOOM-J5 pin 6	#26 TSP w/7,8
7	MAG Heater RET	BOOM-J5 pin 7	#26 TSP w/6,8
8	MAG Heater Shield	BOOM-J5 pin 8	#26 TSP Shield
9	XYZ Drive RET, T2 Ret	BOOM-J5 pin 9	Coax Shield w/1
10	X Sensor Sig RET	BOOM-J5 pin 10	Coax Shield w/2
11	Y Sensor Sig RET	BOOM-J5 pin 11	Coax Shield w/3
12	Z Sensor Sig RET	BOOM-J5 pin 12	Coax Shield w/4
13	MAG Temp Sensor RET	BOOM-J5 pin 13	#26 TSP w/5,14
14	MAG Temp Sensor Shield, T2	BOOM-J5 pin 14	#26 TSP Shield
15	Chassis (Connect to thermal blanket ground at MAG)	Boom chassis ground	Overshield & Backshell

The wire bundle up the boom consists of the wires to MAG-J1 and SWEA-P1. This includes 7 coaxes and 5 twisted shielded pairs. A common over-shield shall be tied to chassis ground at both ends (the bottom of the boom and SWEA; MAG thermal blankets should also be connected to over-shield ground). For most of the length of the harness, the stacer shall be the outer shield; for the extension from SWEA to the MAG a shield will be added.

#### 4.4. SWEA Connectors

##### 4.4.1. SWEA-P1 (IDPU to SWEA)

See section 4.3.6

##### 4.4.2. SWEA-P3 (HV/Actuator Enable)

Pin	Signal	Destination	Harness
13	28V Supply	SWEA-P3 pin 11	
12	28V Supply	SWEA-P3 pin 2	
15	SWEA Cover Act. Supply	SWEA-P3 pin 8	
10	STE Cover Open Act. Supply	SWEA-P3 pin 4	
9	STE Cover Close Act. Supply	SWEA-P3 pin 7	
11	28V MCP HV	SWEA-P3 pin 13	
2	28V NC HV	SWEA-P3 pin 12	
8	SWEA Cover Act.	SWEA P3-pin 15	
4	STE Cover Open Act.	SWEA-P3 pin 10	
7	STE Cover Close Act.	SWEA-P3 pin 9	
	28V Supply RET		
	28V Supply RET		
	Actuator RET		
	Actuator RET		
	Actuator RET		

Note: The RET signals are for test purposes (a dummy load/indicator can be installed between the supply and RET signals to verify operation)

#### 4.5. SEP Connectors

##### 4.5.1. SEP-P1 (SEP Power)

Pin	Signal	Destination	Harness
1	Spare		
2	+28V Primary	Spacecraft	#22 TP w/10
3	+28V Redundant	Spacecraft	#22 TP w/11
4	Spare		
5	+28V Heater Primary	Spacecraft	#22 TP w/13
6	+28V Heater Redundant	Spacecraft	#22 TP w/14
7	Spare		
8	Chassis (connected in SEP to SEP chassis)		
9	Spare		
10	+28V Return Primary	Spacecraft	#22 TP w/2
11	+28V Return Redundant	Spacecraft	#22 TP w/3
12	Spare		
13	+28V Heater Return Primary	Spacecraft	#22 TP w/5
14	+28V Heater Return Redundant	Spacecraft	#22 TP w/6
15	Spare		

##### 4.5.2. SEP-P2 (SEP S/C Temp. Sensors)

Pin	Signal	Destination	Harness
1	SEP Temp Sensor	Spacecraft	
2	SEPT-NS Temp Sensor	Spacecraft	
3	SIT S/C TEMP	Spacecraft	
4	SEPT-E S/C TEMP	Spacecraft	
5	HET S/C TEMP	Spacecraft	
6	LET S/C TEMP	Spacecraft	
7	Spare		
8	Spare		
9	SEP Temp Sensor RTN	Spacecraft	
10	SEPT-NS S/C TEMP RTN	Spacecraft	
11	SIT S/C TEMP RTN	Spacecraft	
12	SEPT-E S/C TEMP RTN	Spacecraft	
13	HET S/C TEMP RTN	Spacecraft	
14	LET S/C TEMP RTN	Spacecraft	
15	Chassis (connected in SEP to SEP chassis)		

## 4.5.3. SEP-P3 (SIT &amp; SEPT Cover Actuators)

(Reconfigured, see 4.6.3; 4.7.3 and 4.8.3)

## 4.5.4. SEP-P4 (SEP to IDPU)

Pin	Signal	Destination	Harness
1	CLK	IDPU-P4 pin 1	Coax w/2
2	CLK-RET	IDPU-P4 pin 2	Coax Shield w/1
3	Spare		
4	Spare		
5	Spare		
6	CMD	IDPU-P4 pin 6	Coax w/7
7	CMD-RET	IDPU-P4 pin 7	Coax Shield w/6
8	Spare		
9	Spare		
10	Spare		
11	TLM	IDPU-P4 pin 11	Coax w/12
12	TLM-RET	IDPU-P4 pin 12	Coax Shield w/11
13	Spare		
14	Spare		
15	Chassis (connected in SEP to SEP chassis)		

(Note: This is a 1:1 harness)

## 4.5.5. SEP-P5 (SEP to SIT)

Pin	Signal	Destination	Harness
1	PWR RTN	SIT-P1 pin 1 SIT-P1 pin 2	#26 #26 T5 w/10,12,34,36
2	PWR RTN	SIT-P1 pin 3	#26 T5 w/11,13,35,37
3	PWR RTN	SIT-P1 pin 4	#26 T5 w/6,42,44,46
4	+5V ANA	SIT-P1 pin 5	#26 T5 w/7,43,45,47
5	+5V ANA	SIT-P1 pin 6	#26 T5 w/4,42,44,46
6	-5V REF	SIT-P1 pin 7	#26 T5 w/5.43.45.47
7	-5V REF		
8	Spare		
9	Spare		
10	+2.5V DIG	SIT-P1 pin 10	#26 T5 w/2,12,34,36
11	+2.5V DIG	SIT-P1 pin 11 SIT-P1 pin 12	#26 T5 w/3,13,35,37 #26 T5 w/2, 10, 34, 36
12	+3.3V DIG	SIT-P1 pin 13	#26 T5 w/3,11,35,37
13	+3.3V DIG	SIT-P1 pin 14	#26 TSP w/16, 18
14	SIT RESET	SIT-P1 pin 15	#26 TSP w/17, 19
15	SIT RESET	SIT-P1 pin 16	#26 TSP w/14, 18
16	SIT CMD IN	SIT-P1 pin 17	#26 TSP w/15, 19
17	SIT CMD IN	SIT-P1 pin 18	TSP Shld w/14,16
18	SIT MSTR SGNL RTN	SIT-P1 pin 19	TSP Shld w/15,17
19	SIT MSTR SGNL RTN	SIT-P1 pin 20	#26 TSP w/22, 24
20	SIT CMD OUT	SIT-P1 pin 21	#26 TSP w/23,25
21	SIT CMD OUT	SIT-P1 pin 22	#26 TSP w/20, 24
22	SIT DATA OUT	SIT-P1 pin 23	#26 TSP w/21, 25
23	SIT DATA OUT	SIT-P1 pin 24	TSP Shld w/20,22
24	SIT SUB SGNL RTN	SIT-P1 pin 25	TSP Shld w/21,23
25	SIT SUB SGNL RTN	SIT-P1 pin 26	#26 TT w/27,28
26	SIT INT TEMP1	SIT-P1 pin 27	#26 TT w/26,28
27	SIT INT TEMP2	SIT-P1 pin 28	#26 TT w/26,27
28	SIT INT TEMP RTN		
29	Spare		
30	SIT BIAS (150-200V)	SIT-P1 pin 30	#26
31	SIT BIAS (150-200V)	SIT-P1 pin 31	#26
32	Spare		
33	Spare		
34	-5.2V DIG	SIT-P1 pin 34	#26 T5 w/2,10,12,36
35	-5.2V DIG	SIT-P1 pin 35	#26 T5 w/3,11,13,37
36	+5V DIG	SIT-P1 pin 36	#26 T5 w/2,10,12,34
37	+5V DIG	SIT-P1 pin 37	#26 T5 w/3,11,13,35
38	SIT HV MON	SIT-P1 pin 38	#26 TP w/39

39	SIT HV MON RTN	SIT-P1 pin 39	#26 TP w/38
40	Spare		
41	Spare		
42	+13V ANA	SIT-P1 pin 42	#26 T5 w/4,6,44,46
43	+13V ANA	SIT-P1 pin 43	#26 T5 w/5,7,45,47
44	PWR RTN	SIT-P1 pin 44	#26 T5 w/4,6,42,46
45	PWR RTN	SIT-P1 pin 45	#26 T5 w/5,7,43,47
46	-13V ANA	SIT-P1 pin 46	#26 T5 w/4,6,42,44
47	-13V ANA	SIT-P1 pin 47	#26 T5 w/5,7,43,45
48	SIT S/C TEMP	SIT-P1 pin 48	#26 TP w/49
49	SIT S/C TEMP RTN	SIT-P1 pin 49	#26 TP w/48
50	Spare		
51	Chassis (connected in SIT to SIT chassis)		

(Note: This is a 1:1 harness)

## 4.5.6. SEP-P6 (SEP to SEPT-NS)

Removed

## 4.5.7. SEP-P7 (SEP to SEPT-NS)

Pin	Signal	Destination	Harness
1	SEPT-NS Bias	SEPTNS-P2 pin 1	#28 TQ w/2,20,21
2	SEPT-NS Bias RTN	SEPTNS-P2 pin 2	#28 TQ w/1,20,21
3	SEPT-NS Ana RTN	SEPTNS-P2 pin 3	#28 TQ w/4,22,23
4	SEPT-NS +5.6VA	SEPTNS-P2 pin 4	#28 TQ w/4,22,23
5	SEPT-NS Dig RTN	SEPTNS-P2 pin 5	#28 T6 w/6,7,24,25,26
6	SEPT-NS +2.6VD	SEPTNS-P2 pin 6	#28 T6 w/5,7,24,25,26
7	SEPT-NS +5.6VD	SEPTNS-P2 pin 7	#28 T6 w/5,6,24,25,26
8	SEPT-NS Star Ground	SEPTNS-P2 pin 8	#28
9	SEPT-NS Cmd In	SEPTNS-P2 pin 9	#28 TS8 w/10,11,12,28,29,30,31
10	SEPT-NS Mstr RTN	SEPTNS-P2 pin 10	#28 TS8 w/9,11,12,28,29,30,31
11	SEPT-NS Data Out	SEPTNS-P2 pin 11	#28 TS8 w/9,10,12,28,29,30,31
12	SEPT-NS Sub RTN	SEPTNS-P2 pin 12	#28 TS8 w/9,10,11,28,29,30,31
13	SEPT-NS S/C Temp	SEPTNS-P2 pin 13	#28 TQ w/14,32,33
14	SEPT-NS S/C Temp RTN	SEPTNS-P2 pin 14	#28 TP w/13,32,33
15	SEPT-NS Op Htr	SEPTNS-P1 pin 1	#28 TS8 w/16,17,18,34,35,36,37
16	SEPT-NS Op Htr RTN	SEPTNS-P1 pin 2	#28 TS8 w/15,16,17,34,35,36,37
17	SEPT-NS Survival Htr	SEPTNS-P1 pin 3	#28 TS8 w/15,16,18,34,35,36,37
18	SEPT-NS Survival Htr RTN	SEPTNS-P1 pin 4	#28 TS8 w/15,16,17,34,35,36,37
19	SEPT-NS Internal Shield	SEPTNS-P2 pin 16	TS8 shield (10,11,etc.)
20	SEPT-NS Bias Red.	SEPTNS-P2 pin 17	#28 TQ w/1,2,21
21	SEPT-NS Bias RTN Red.	SEPTNS-P2 pin 18	#28 TQ w/1,2,20
22	SEPT-NS Ana RTN Red.	SEPTNS-P2 pin 19	#28 TQ w/3,4,23
23	SEPT-NS +5.6VA Red.	SEPTNS-P2 pin 20	#28 TQ w/3,4,22
24	SEPT-NS Dig RTN Red.	SEPTNS-P2 pin 21	#28 T6 w/5,6,7,25,26
25	SEPT-NS +2.6VD Red.	SEPTNS-P2 pin 22	#28 T6 w/5,6,7,24,26
26	SEPT-NS +5.6VD Red.	SEPTNS-P2 pin 23	#28 T6 w/5,6,7,24,25
27	SEPT-NS Star Ground Red.	SEPTNS-P2 pin 24	#28
28	SEPT-NS Cmd In Red.	SEPTNS-P2 pin 25	#28 TS8 w/9,10,11,12,29,30,31
29	SEPT-NS Mstr RTN Red.	SEPTNS-P2 pin 26	#28 TS8 w/9,10,11,12,28,30,31
30	SEPT-NS Data Out Red.	SEPTNS-P2 pin 27	#28 TS8 w/9,10,11,12,28,29,31
31	SEPT-NS Sub RTN Red.	SEPTNS-P2 pin 28	#28 TS8 w/9,10,11,12,28,29,30
32	SEPT-NS S/C Temp Red	SEPTNS-P2 pin 29	#28 TQ w/13,14,33
	SEPT-NS S/C Temp RTN	SEPTNS-P2 pin 30	#28 TQ w/13,14,32
33	Red.		
34	SEPT-NS Op Htr Red.	SEPTNS-P1 pin 6	#28 TS8 w/15,16,17,18,35,36,37
35	SEPT-NS Op Htr RTN Red.	SEPTNS-P1 pin 7	#28 TS8 w/15,16,17,18,34,36,37
36	SEPT-NS Survival Htr Red.	SEPTNS-P1 pin 3	#28 TS8 w/15,16,17,18,34,35,37
	SEPT-NS Survival Htr RTN	SEPTNS-P1 pin 4	#28 TS8 w/15,16,17,18,34,35,36
37	Red.		(TS8 shield to backshell)

## 4.5.8. SEP-P8 (SEP to SEPT-E)

Removed

## 4.5.9. SEP-P9 (SEP to SEPT-E)

Pin	Signal	Destination	Harness
1	SEPT-E Bias	SEPTE-P2 pin 1	#28 TQ w/2,20,21
2	SEPT-E Bias RTN	SEPTE-P2 pin 2	#28 TQ w/1,20,21
3	SEPT-E Ana RTN	SEPTE-P2 pin 3	#28 TQ w/4,22,23
4	SEPT-E +5.6VA	SEPTE-P2 pin 4	#28 TQ w/4,22,23
5	SEPT-E Dig RTN	SEPTE-P2 pin 5	#28 T6 w/6,7,24,25,26
6	SEPT-E +2.6VD	SEPTE-P2 pin 6	#28 T6 w/5,7,24,25,26
7	SEPT-E +5.6VD	SEPTE-P2 pin 7	#28 T6 w/5,6,24,25,26
8	SEPT-E Star Ground	SEPTE-P2 pin 8	#28
9	SEPT-E Cmd In	SEPTE-P2 pin 9	#28 TS8 w/10,11,12,28,29,30,31
10	SEPT-E Mstr RTN	SEPTE-P2 pin 10	#28 TS8 w/9,11,12,28,29,30,31
11	SEPT-E Data Out	SEPTE-P2 pin 11	#28 TS8 w/9,10,12,28,29,30,31
12	SEPT-E Sub RTN	SEPTE-P2 pin 12	#28 TS8 w/9,10,11,28,29,30,31
13	SEPT-E S/C Temp	SEPTE-P2 pin 13	#28 TQ w/14,32,33
14	SEPT-E S/C Temp RTN	SEPTE-P2 pin 14	#28 TP w/13,32,33
15	SEPT-E Op Htr	SEPTE-P1 pin 1	#28 TS8 w/16,17,18,34,35,36,37
16	SEPT-E Op Htr RTN	SEPTE-P1 pin 2	#28 TS8 w/15,16,17,34,35,36,37
17	SEPT-E Survival Htr	SEPTE-P1 pin 3	#28 TS8 w/15,16,18,34,35,36,37
18	SEPT-E Survival Htr RTN	SEPTE-P1 pin 4	#28 TS8 w/15,16,17,34,35,36,37
19	SEPT-E Internal Shield	SEPTE-P2 pin 16	TS8 shield (10,11,etc.)
20	SEPT-E Bias Red.	SEPTE-P2 pin 17	#28 TQ w/1,2,21
21	SEPT-E Bias RTN Red.	SEPTE-P2 pin 18	#28 TQ w/1,2,20
22	SEPT-E Ana RTN Red.	SEPTE-P2 pin 19	#28 TQ w/3,4,23
23	SEPT-E +5.6VA Red.	SEPTE-P2 pin 20	#28 TQ w/3,4,22
24	SEPT-E Dig RTN Red.	SEPTE-P2 pin 21	#28 T6 w/5,6,7,25,26
25	SEPT-E +2.6VD Red.	SEPTE-P2 pin 22	#28 T6 w/5,6,7,24,26
26	SEPT-E +5.6VD Red.	SEPTE-P2 pin 23	#28 T6 w/5,6,7,24,25
27	SEPT-E Star Ground Red.	SEPTE-P2 pin 24	#28
28	SEPT-E Cmd In Red.	SEPTE-P2 pin 25	#28 TS8 w/9,10,11,12,29,30,31
29	SEPT-E Mstr RTN Red.	SEPTE-P2 pin 26	#28 TS8 w/9,10,11,12,28,30,31
30	SEPT-E Data Out Red.	SEPTE-P2 pin 27	#28 TS8 w/9,10,11,12,28,29,31
31	SEPT-E Sub RTN Red.	SEPTE-P2 pin 28	#28 TS8 w/9,10,11,12,28,29,30
32	SEPT-E S/C Temp Red	SEPTE-P2 pin 29	#28 TQ w/13,14,33
	SEPT-E S/C Temp RTN	SEPTE-P2 pin 30	#28 TQ w/13,14,32
33	Red.		
34	SEPT-E Op Htr Red.	SEPTE-P1 pin 6	#28 TS8 w/15,16,17,18,35,36,37
35	SEPT-E Op Htr RTN Red.	SEPTE-P1 pin 7	#28 TS8 w/15,16,17,18,34,36,37
36	SEPT-E Survival Htr Red.	SEPTE-P1 pin 3	#28 TS8 w/15,16,17,18,34,35,37
	SEPT-E Survival Htr RTN	SEPTE-P1 pin 4	#28 TS8 w/15,16,17,18,34,35,36
37	Red.		(TS8 shield to backshell)



#### 4.6. SEPT-E Connectors

##### 4.6.1. SEPT-E-P1 (SEP to SEPT-E)

Pin	Signal	Destination	Harness
1	SEPT-E Op Htr	SEP-P9 pin 15	#28 TS8 w/16,17,18,34,35,36,37
2	SEPT-E Op Htr RTN	SEP-P9 pin 16	#28 TS8 w/15,16,17,34,35,36,37
3	SEPT-E Survival Htr	SEP-P9 pin 17	#28 TS8 w/15,16,18,34,35,36,37
4	SEPT-E Survival Htr RTN	SEP-P9 pin 18	#28 TS8 w/15,16,17,34,35,36,37
5	SEPT-E Chassis Ground		
6	SEPT-E Op Htr Red.	SEP-P9 pin 34	#28 TS8 w/15,16,17,18,35,36,37
7	SEPT-E Op Htr RTN Red.	SEP-P9 pin 35	#28 TS8 w/15,16,17,18,34,36,37
8	SEPT-E Survival Htr Red.	SEP-P9 pin 36	#28 TS8 w/15,16,17,18,34,35,37
9	SEPT-E Survival Htr RTN Red.	SEP-P9 pin 37	#28 TS8 w/15,16,17,18,34,35,36 (TS8 shield to backshell)

##### 4.6.2. SEPT-E-P2 (SEP to SEPT-E)

Pin	Signal	Destination	Harness
1	SEPT-E Bias	SEP-P9 pin 1	#28 TQ w/2,17,18
2	SEPT-E Bias RTN	SEP-P9 pin 2	#28 TQ w/1,17,18
3	SEPT-E Ana RTN	SEP-P9 pin 3	#28 TQ w/4,19,20
4	SEPT-E +5.6VA	SEP-P9 pin 4	#28 TQ w/4,19,20
5	SEPT-E Dig RTN	SEP-P9 pin 5	#28 T6 w/6,7,21,22,23
6	SEPT-E +2.6VD	SEP-P9 pin 6	#28 T6 w/5,7,21,22,23
7	SEPT-E +5.6VD	SEP-P9 pin 7	#28 T6 w/5,6,21,22,23
8	SEPT-E Star Ground	SEP-P9 pin 8	#28
9	SEPT-E Cmd In	SEP-P9 pin 9	#28 TS8 w/10,11,12,25,26,27,28
10	SEPT-E Mstr RTN	SEP-P9 pin 10	#28 TS8 w/9,11,12, 25,26,27,28
11	SEPT-E Data Out	SEP-P9 pin 11	#28 TS8 w/9,10,12, 25,26,27,28
12	SEPT-E Sub RTN	SEP-P9 pin 12	#28 TS8 w/9,10,11, 25,26,27,28
13	SEPT-E S/C Temp	SEP-P9 pin 13	#28 TQ w/14,29,30
14	SEPT-E S/C Temp RTN	SEP-P9 pin 14	#28 TQ w/13,29,30
15	Spare		
16	SEPT-E Internal Shield	SEP-P9 pin 19	TS8 shield (10,11,etc.)
17	SEPT-E Bias Red.	SEP-P9 pin 20	#28 TQ w/1,2,18
18	SEPT-E Bias RTN Red.	SEP-P9 pin 21	#28 TQ w/1,2,17
19	SEPT-E Ana RTN Red.	SEP-P9 pin 22	#28 TQ w/3,4,23
20	SEPT-E +5.6VA Red.	SEP-P9 pin 23	#28 TQ w/3,4,22
21	SEPT-E Dig RTN Red.	SEP-P9 pin 24	#28 T6 w/5,6,7,25,26
22	SEPT-E +2.6VD Red.	SEP-P9 pin 25	#28 T6 w/5,6,7,24,26
23	SEPT-E +5.6VD Red.	SEP-P9 pin 26	#28 T6 w/5,6,7,24,25
24	SEPT-E Star Ground Red.	SEP-P9 pin 27	#28
25	SEPT-E Cmd In Red.	SEP-P9 pin 28	#28 TS8 w/9,10,11,12,26,27,28

26	SEPT-E Mstr RTN Red.	SEP-P9 pin 29	#28 TS8 w/9,10,11,12,25,27,28
27	SEPT-E Data Out Red.	SEP-P9 pin 30	#28 TS8 w/9,10,11,12,25,26,28
28	SEPT-E Sub RTN Red.	SEP-P9 pin 31	#28 TS8 w/9,10,11,12,25,26,27
29	SEPT-E S/C Temp Red	SEP-P9 pin 32	#28 TQ w/13,14,30
	SEPT-E S/C Temp RTN	SEP-P9 pin 33	#28 TQ w/13,14,29
30	Red.		
31	Spare		

## 4.6.3. SEPT-E-P3 (S/C to SEPT-E)

Pin	Signal	Destination	Harness
1	SEPT-E ACT1	Spacecraft	#22 TSQ w/2,3,4
2	SEPT-E ACT1	Spacecraft	#22 TSQ w/1,3,4
3	SEPT-E ACT1 RTN	Spacecraft	#22 TSQ w/1,2,4
4	SEPT-E ACT1 RTN	Spacecraft	#22 TSQ w/1,2,3
5	SEPT-E ACT2	Spacecraft	#22 TSQ w/6,7,8
6	SEPT-E ACT2	Spacecraft	#22 TSQ w/5,7,8
7	SEPT-E ACT2 RTN	Spacecraft	#22 TSQ w/5,6,8
8	SEPT-E ACT2 RTN	Spacecraft	#22 TSQ w/5,6,7
9	Chassis (con. in SEPT-NS to SEPT-NS chassis)		

#### 4.7. SEPT-NS Connectors

##### 4.7.1. SEPTNS-P1 (SEP to SEPT-NS)

Pin	Signal	Destination	Harness
1	SEPT-NS Op Htr	SEP-P7 pin 15	#28 TS8 w/16,17,18,34,35,36,37
2	SEPT-NS Op Htr RTN	SEP-P7 pin 16	#28 TS8 w/15,16,17,34,35,36,37
3	SEPT-NS Survival Htr	SEP-P7 pin 17	#28 TS8 w/15,16,18,34,35,36,37
4	SEPT-NS Survival Htr RTN	SEP-P7 pin 18	#28 TS8 w/15,16,17,34,35,36,37
5	SEPT-NS Chassis Ground		
6	SEPT-NS Op Htr Red.	SEP-P7 pin 34	#28 TS8 w/15,16,17,18,35,36,37
7	SEPT-NS Op Htr RTN Red.	SEP-P7 pin 35	#28 TS8 w/15,16,17,18,34,36,37
8	SEPT-NS Survival Htr Red.	SEP-P7 pin 36	#28 TS8 w/15,16,17,18,34,35,37
9	SEPT-NS Survival Htr RTN Red.	SEP-P7 pin 37	#28 TS8 w/15,16,17,18,34,35,36 (TS8 shield to backshell)

##### 4.7.2. SEPTNS-P2 (SEP to SEPT-NS)

Pin	Signal	Destination	Harness
1	SEPT-NS Bias	SEP-P7 pin 1	#28 TQ w/2,17,18
2	SEPT-NS Bias RTN	SEP-P7 pin 2	#28 TQ w/1,17,18
3	SEPT-NS Ana RTN	SEP-P7 pin 3	#28 TQ w/4,19,20
4	SEPT-NS +5.6VA	SEP-P7 pin 4	#28 TQ w/4,19,20
5	SEPT-NS Dig RTN	SEP-P7 pin 5	#28 T6 w/6,7,21,22,23
6	SEPT-NS +2.6VD	SEP-P7 pin 6	#28 T6 w/5,7,21,22,23
7	SEPT-NS +5.6VD	SEP-P7 pin 7	#28 T6 w/5,6,21,22,23
8	SEPT-NS Star Ground	SEP-P7 pin 8	#28
9	SEPT-NS Cmd In	SEP-P7 pin 9	#28 TS8 w/10,11,12,25,26,27,28
10	SEPT-NS Mstr RTN	SEP-P7 pin 10	#28 TS8 w/9,11,12, 25,26,27,28
11	SEPT-NS Data Out	SEP-P7 pin 11	#28 TS8 w/9,10,12, 25,26,27,28
12	SEPT-NS Sub RTN	SEP-P7 pin 12	#28 TS8 w/9,10,11, 25,26,27,28
13	SEPT-NS S/C Temp	SEP-P7 pin 13	#28 TQ w/14,29,30
14	SEPT-NS S/C Temp RTN	SEP-P7 pin 14	#28 TQ w/13,29,30
15	Spare		
16	SEPT-NS Internal Shield	SEP-P7 pin 19	TS8 shield (10,11,etc.)
17	SEPT-NS Bias Red.	SEP-P7 pin 20	#28 TQ w/1,2,18
18	SEPT-NS Bias RTN Red.	SEP-P7 pin 21	#28 TQ w/1,2,17
19	SEPT-NS Ana RTN Red.	SEP-P7 pin 22	#28 TQ w/3,4,23
20	SEPT-NS +5.6VA Red.	SEP-P7 pin 23	#28 TQ w/3,4,22
21	SEPT-NS Dig RTN Red.	SEP-P7 pin 24	#28 T6 w/5,6,7,25,26
22	SEPT-NS +2.6VD Red.	SEP-P7 pin 25	#28 T6 w/5,6,7,24,26
23	SEPT-NS +5.6VD Red.	SEP-P7 pin 26	#28 T6 w/5,6,7,24,25
24	SEPT-NS Star Ground Red.	SEP-P7 pin 27	#28
25	SEPT-NS Cmd In Red.	SEP-P7 pin 28	#28 TS8 w/9,10,11,12,26,27,28
26	SEPT-NS Mstr RTN Red.	SEP-P79 pin 29	#28 TS8 w/9,10,11,12,25,27,28

27	SEPT-NS Data Out Red.	SEP-P7 pin 30	#28 TS8 w/9,10,11,12,25,26,28
28	SEPT-NS Sub RTN Red.	SEP-P7 pin 31	#28 TS8 w/9,10,11,12,25,26,27
29	SEPT-NS S/C Temp Red	SEP-P7 pin 32	#28 TQ w/13,14,30
	SEPT-NS S/C Temp RTN	SEP-P7 pin 33	#28 TQ w/13,14,29
30	Red.		
31	Spare		

## 4.7.3. SEPTNS-P3 (S/C to SEPT-NS)

Pin	Signal	Destination	Harness
1	SEPT-NS ACT1	Spacecraft	#22 TSQ w/2,3,4
2	SEPT-NS ACT1	Spacecraft	#22 TSQ w/1,3,4
3	SEPT-NS ACT1 RTN	Spacecraft	#22 TSQ w/1,2,4
4	SEPT-NS ACT1 RTN	Spacecraft	#22 TSQ w/1,2,3
5	SEPT-NS ACT2	Spacecraft	#22 TSQ w/6,7,8
6	SEPT-NS ACT2	Spacecraft	#22 TSQ w/5,7,8
7	SEPT-NS ACT2 RTN	Spacecraft	#22 TSQ w/5,6,8
8	SEPT-NS ACT2 RTN	Spacecraft	#22 TSQ w/5,6,7
9	Chassis (con. in SEPT-NS to SEPT-NS chassis)		

#### 4.8. SIT Connectors

##### 4.8.1. SIT-P1 (SEP to SIT)

Pin	Signal	Destination	Harness
1	PWR RTN	SEP-P5 pin 1	#26
2	PWR RTN	SEP-P5 pin 2	#26 T5 w/10,12,34,36
3	PWR RTN	SEP-P5 pin 3	#26 T5 w/11,13,35,37
4	+5V ANA	SEP-P5 pin 4	#26 T5 w/6,42,44,46
5	+5V ANA	SEP-P5 pin 5	#26 T5 w/7,43,45,47
6	-5V REF	SEP-P5 pin 6	#26 T5 w/4,42,44,46
7	-5V REF	SEP-P5 pin 7	#26 T5 w/5,43,45,47
8	Spare		
9	Spare		
10	+2.5V DIG	SEP-P5 pin 10	#26 T5 w/2,12,34,36
11	+2.5V DIG	SEP-P5 pin 11	#26 T5 w/3,13,35,37
12	+3.3V DIG	SEP-P5 pin 12	#26 T5 w/2, 10, 34, 36
13	+3.3V DIG	SEP-P5 pin 13	#26 T5 w/3,11,35,37
14	SIT RESET	SEP-P5 pin 14	#26 TSP w/16, 18
15	SIT RESET	SEP-P5 pin 15	#26 TSP w/17, 19
16	SIT CMD IN	SEP-P5 pin 16	#26 TSP w/14, 18
17	SIT CMD IN	SEP-P5 pin 17	#26 TSP w/15, 19
18	SIT MSTR SGNL RTN	SEP-P5 pin 18	TSP Shld w/14,16
19	SIT MSTR SGNL RTN	SEP-P5 pin 19	TSP Shld w/15,17
20	SIT CMD OUT	SEP-P5 pin 20	#26 TSP w/22, 24
21	SIT CMD OUT	SEP-P5 pin 21	#26 TSP w/23,25
22	SIT DATA OUT	SEP-P5 pin 22	#26 TSP w/20, 24
23	SIT DATA OUT	SEP-P5 pin 23	#26 TSP w/21, 25
24	SIT SUB SGNL RTN	SEP-P5 pin 24	TSP Shld w/20,22
25	SIT SUB SGNL RTN	SEP-P5 pin 25	TSP Shld w/21,23
26	SIT INT TEMP1	SEP-P5 pin 26	#26 TT w/27,28
27	SIT INT TEMP2	SEP-P5 pin 27	#26 TT w/26,28
28	SIT INT TEMP RTN	SEP-P5 pin 28	#26 TT w/26,27
29	Spare		
30	SIT BIAS (150-200V)	SEP-P5 pin 30	#26
31	SIT BIAS (150-200V)	SEP-P5 pin 31	#26
32	Spare		
33	Spare		
34	-5.2V DIG	SEP-P5 pin 34	#26 T5 w/2,10,12,36
35	-5.2V DIG	SEP-P5 pin 35	#26 T5 w/3,11,13,37
36	+5V DIG	SEP-P5 pin 36	#26 T5 w/2,10,12,34
37	+5V DIG	SEP-P5 pin 37	#26 T5 w/3,11,13,35
38	SIT HV MON	SEP-P5 pin 38	#26 TP w/39
39	SIT HV MON RTN	SEP-P5 pin 39	#26 TP w/38

40	Spare		
41	Spare		
42	+13V ANA	SEP-P5 pin 42	#26 T5 w/4,6,44,46
43	+13V ANA	SEP-P5 pin 43	#26 T5 w/5,7,45,47
44	PWR RTN	SEP-P5 pin 44	#26 T5 w/4,6,42,46
45	PWR RTN	SEP-P5 pin 45	#26 T5 w/5,7,43,47
46	-13V ANA	SEP-P5 pin 46	#26 T5 w/4,6,42,44
47	-13V ANA	SEP-P5 pin 47	#26 T5 w/5,7,43,45
48	SIT S/C TEMP	SEP-P5 pin 48	#26 TP w/49
49	SIT S/C TEMP RTN	SEP-P5 pin 49	#26 TP w/48
50	Spare		
51	Chassis (connected in SIT to SIT chassis)		

(Note: This is a 1:1 harness)

4.8.2. SIT-P2 (SIT HV Disable/Test)

TBD-SIT-004

4.8.3. SIT-P3 (S/C to SIT)

Pin	Signal	Destination	Harness
1	SIT ACT	Spacecraft	#22 TSQ
2	SIT ACT	Spacecraft	#22 TSQ
3	Spare		
4	Spare		
5	Spare		
6	SIT ACT RTN	Spacecraft	#22 TSQ
7	SIT ACT RTN	Spacecraft	#22 TSQ
8	Spare		
9	Spare		

## 5. Harness Responsibilities

APL is responsible for the harness between the spacecraft systems and IMPACT, including the harnesses to:

- IDPU-P1
- IDPU-P2
- BOOM-P1
- BOOM-P2
- BOOM-P3
- SEP-P1
- SEP-P2
- SIT-P3
- SEPTE-P3
- SEPTNS-P3

UCB is responsible for the harness between PLASTIC and IDPU-P3 |

UCB is responsible for the following harnesses:

- IDPU-P4 to SEP-P4
- IDPU-P5 to BOOM-P4
- IDPU-P6 to BOOM-P5
- IDPU-P7 to BOOM-P6
- 
- Boom Harness:
  - BOOM-J5 to MAG-J1,
  - BOOM-J1, J2, J4 to SWEA-P1
- SWEA-P3 enable plug(s) |

GSFC/Acuna is responsible for the pig-tail on MAG to MAG-P1

Caltech & UCB (Caltech defines & provides connectors; UCB to build) are responsible for: |

SEPTNS-P1 and SEPTNS-P2 to SEP-P7  
SEPTE-P1 and SEPTE-P2 to SEP-P9  
SEP-P5 to SIT-P1 |

UMd is responsible for the SIT-P2 disable plug/test access harness