

STEREO *IMPACT*

Harness Specification

IMPACTHarnessSpec_C.doc
Version C – 2001-Aug-01

David Curtis, UCB IMPACT Project Manager

Document Revision Record

Rev.	Date	Description of Change	Approved By
A	2001-Mar-16	Preliminary Draft	-
B	2001-Mar-20	?? Add harness responsibilities ?? Add details of spacecraft harness ?? Minor fixes	-
C	2001-Aug-1	?? Change power from TP to TSQ ?? Add BOOM temp sensor to BOOM-P2 ?? Split STE, SEPT-E, SIT	

Distribution List

Dave Curtis, UCB
 Peter Berg, UCB
 Robert Ulrich, UCB
 Steve McBride, UCB
 Andy Driesman, APL
 Mario Acuna, GSFC (MAG)
 Tycho von Rosenvinge, GSFC (SEP)
 Alan Cummings, CalTech (SEP)
 Reinhold Mueller-Mellin, Keil (SEPT)
 Peter Walpole, Umd (SIT)
 Steven Turco, UNH (PLASTIC)

Table of Contents

Document Revision Record.....	i
Distribution List	i
1. Introduction.....	1
1.1. <i>Document Conventions</i>	1
1.2. <i>Applicable Documents</i>	1
2. Harness Figure	1
3. Connector Types.....	3
3.1. <i>IDPU Connectors</i>	3
3.2. <i>Boom Connectors</i>	3
3.3. <i>SWEA Connectors</i>	4
3.4. <i>MAG Connector</i>	4
3.5. <i>SEP Connectors</i>	4
3.6. <i>SEPT-E Connectors</i>	5
3.7. <i>SEPT-NS Connectors</i>	5
3.8. <i>SIT Connectors</i>	5
3.9. <i>HET Connector</i>	5
3.10. <i>LET Connector</i>	5
4. Connector Pinouts	6
4.1. <i>IDPU Connectors</i>	6
4.1.1. IDPU-P1 (IDPU Power).....	6
4.1.2. IDPU-J2 (1553 Interface to Spacecraft).....	7
4.1.3. IDPU-P3 (IDPU to PLASTIC)	7
4.1.4. IDPU-P4 (IDPU to SEP)	8
4.1.5. IDPU-P5 (IDPU to SWEA/STE).....	8
4.1.6. IDPU-P6 (IDPU to MAG).....	9
4.2. <i>Boom Connectors</i>	10
4.2.1. BOOM-P1 (SWEA/STE Power)	10
4.2.2. BOOM-P2 (SWEA S/C Temp Sensor)	10
4.2.3. BOOM-P3 (Boom Actuator Power)	11
4.2.4. BOOM-P4 (SWEA/STE to IDPU)	11
4.2.5. BOOM-P5 (IDPU to MAG)	12
4.3. <i>Internal Boom Harness</i>	12
4.3.1. BOOM-J1 (SWEA/STE Power).....	12
4.3.2. BOOM-J2 (SWEA S/C Temp Sensor).....	13
4.3.3. BOOM-J4 (SWEA/STE to IDPU)	13
4.3.4. BOOM-J5 (IDPU to MAG).....	14
4.3.5. SWEA-P1 (IDPU to SWEA).....	14
4.3.6. MAG-J1 (IDPU to MAG)	15
4.4. <i>SWEA Connectors</i>	16
4.4.1. SWEA-P1 (IDPU to SWEA).....	16
4.4.2. SWEA-P2 (STE).....	16
4.4.3. SWEA-P3 (HV/Actuator Enable)	17
4.5. <i>SEP Connectors</i>	18
4.5.1. SEP-P1 (SEP Power)	18
4.5.2. SEP-P2 (SEP/SEPT S/C Temp. Sensors).....	18

4.5.3.	SEP-P3 (SIT & SEPT Cover Actuators).....	18
4.5.4.	SEP-P4 (IDPU to SEP).....	19
4.5.5.	SEP-P5 (SEP to SIT).....	19
4.5.6.	SEP-P6 (SEP to SEPT-NS).....	19
4.5.7.	SEP-P7 (SEP to SEPT-NS).....	19
4.5.8.	SEP-P8 (SEP to SEPT-E).....	19
4.5.9.	SEP-P9 (SEP to SEPT-E).....	19
4.5.10.	SEP-P10 (SEP to HET).....	19
4.5.11.	SEP-P11 (SEP to LET).....	19
4.6.	SEPT-E Connectors	20
4.6.1.	SEPTE-P1 (SEP to SEPT-E).....	20
4.6.2.	SEPTE-P2 (SEP to SEPT-E).....	20
4.7.	SEPT-NS Connectors	20
4.7.1.	SEPTNS-P1 (SEP to SEPT-NS).....	20
4.7.2.	SEPTNS-P2 (SEP to SEPT-NS).....	20
4.8.	SIT Connectors	20
4.8.1.	SIT-P1 (SEP to SIT).....	20
4.8.2.	SIT-P2 (SIT HV Disable/Test).....	20
4.9.	HET Connectors	20
4.9.1.	HET-P1 (SEP to HET).....	20
4.10.	LET Connectors	20
4.10.1.	LET-P1 (SEP to LET).....	20
5.	Harness Responsibilities	21

1. Introduction

This specification describes the harnesses between the various parts of the IMPACT instrument suite, as well as the interface connectors to the spacecraft. The spec covers the connector types and pinouts as well as the harness wiring details.

1.1. *Document Conventions*

In this document, **TBD** (To Be Determined) means that no data currently exists. A value followed by **TBR** (To Be Resolved) means that this value is preliminary. In either case, the value is typically followed by a code such as UCB indicating who is responsible for providing the data, and a unique reference number.

1.2. *Applicable Documents*

The following documents include drawings and STEREO Project policies. All documents and drawings can be found on the Berkeley STEREO/IMPACT FTP site:

<http://sprg.ssl.berkeley.edu/impact/dwc/>

1. ICD/**TBD-UCB-000** (IMPACT/Spacecraft ICD)
2. ICD/Impact Serial Interface

2. Harness Figure

Figure 2-1 is a schematic of the STEREO IMPACT harness indicating the connector designations, where they are, and what they connect to.

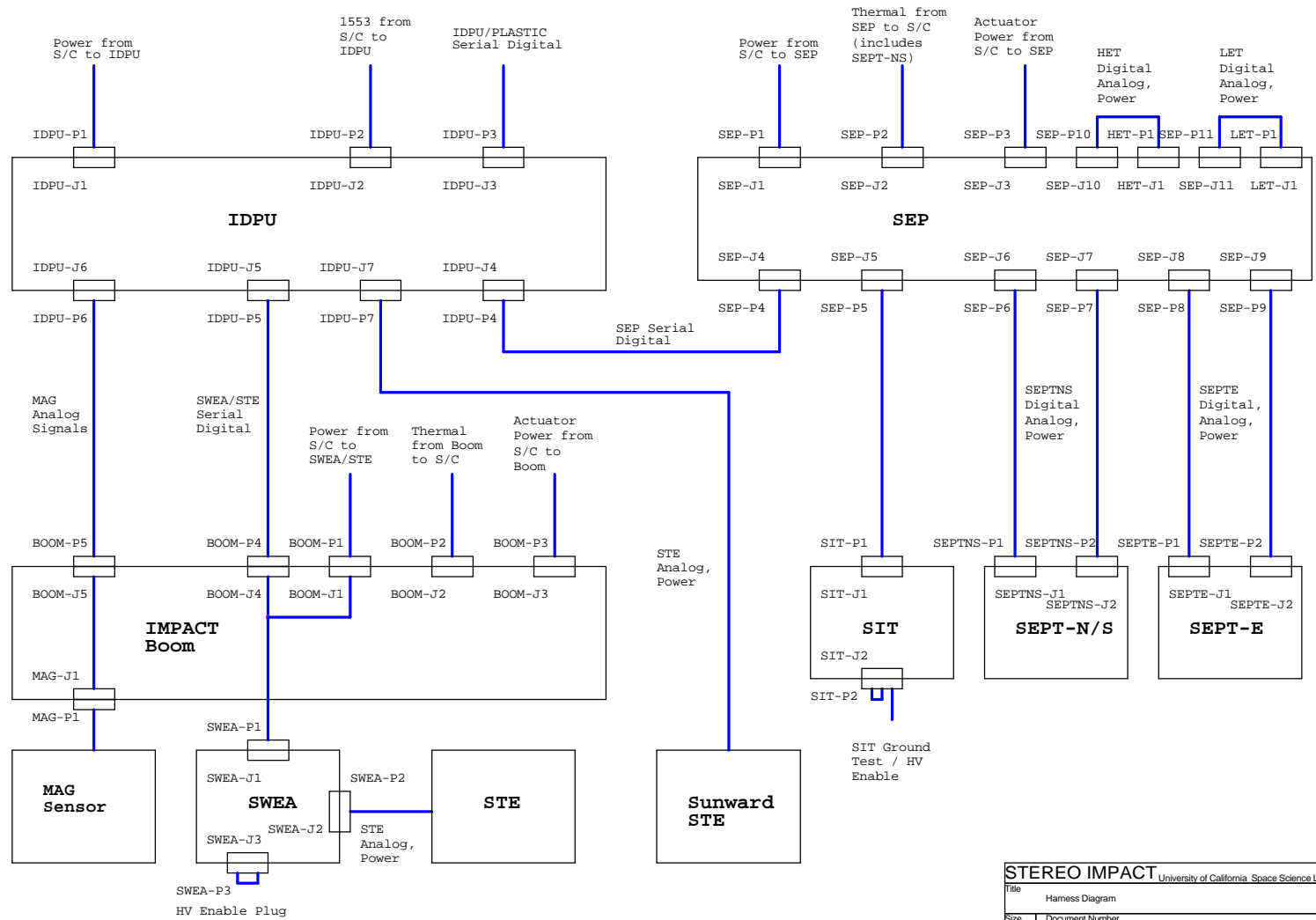

STEREO IMPACT <small>University of California Space Science Lab</small>		
Title: Harness Diagram		
Size: B	Document Number: IMPACT_HARNESS	Rev: C
Date: Monday, July 30, 2001	Sheet: 1	of 1

Figure 2-1 - IMPACT Harness Schematic

3. Connector Types

The instrument harness connectors are described below. "D" connectors are standard density, "HD" are High Density D-type Connectors. Note that these are the HARNESS connectors, not the box connectors. Harness connectors are designated by the box they attach to (such as IPC), followed by -Pn (where n is the connector number on that box), while box connectors designators are identical except they are followed by -Jn.

3.1. IDPU Connectors

Name	Use	Type	Part Number	Mating Connector
IDPU-P1	IDPU Power from Spacecraft	D15S	TBD-APL001	TBD-UCB001
IDPU-P2	1553 Interface from Spacecraft	D9S	TBD-APL001	TBD-UCB001
IDPU-P3	IDPU to PLASTIC Interface	HD15S	TBD-UNH001	TBD-UCB001
IDPU-P4	IDPU to SEP Interface	HD15S	TBD-UCB-001	TBD-UCB-001
IDPU-P5	IDPU to SWEA/STE Interface	HD15S	TBD-UCB-001	TBD-UCB-001
IDPU-P6	IDPU to MAG Interface	HD15P	TBD-UCB-001	TBD-MAG-001
IDPU-P7	IDPU to STE-U Interface	HD26P	TBD-UCB-001	TBD-UCB-001

3.2. Boom Connectors

Name	Use	Type	Part Number	Mating Connector
BOOM-P1	SWEA/STE Power from Spacecraft	D15S	TBD-APL001	TBD-UCB001
BOOM-P2	SWEA Temp Sensor Interface to Spacecraft	D9P	TBD-APL001	TBD-UCB001
BOOM-P3	Boom Actuator Power from Spacecraft	D9S	TBD-APL001	TBD-UCB001
BOOM-P4	IDPU to SWEA/STE Interface	HD15P	TBD-UCB-001	TBD-UCB-001
BOOM-P5	IDPU to MAG Interface	HD15S	TBD-UCB-001	TBD-UCB-001

3.3. SWEA Connectors

Name	Use	Type	Part Number	Mating Connector
SWEA-P1	SWEA/STE Interface (Signal+Power+Temp)	HD15S	TBD-UCB001	TBD-UCB001
SWEA-P2	SWEA to STE Interface (pigtail on STE)	HD26P	TBD-UCB001	TBD-UCB001
SWEA-P3	Enable Plug	HD15P	TBD-UCB001	TBD-UCB001

3.4. MAG Connector

Name	Use	Type	Part Number	Mating Connector
MAG-P1	MAG Sensor Pigtail Connector	HD15P	TBD-MAG001	TBD-UCB001

3.5. SEP Connectors

Name	Use	Type	Part Number	Mating Connector
SEP-P1	SEP Power from Spacecraft	D15S	TBD-APL001	TBD-SEP001
SEP-P2	SEP/SEPT Temp Sensor Interface to Spacecraft	D9P	TBD-APL001	TBD-SEP001
SEP-P3	SIT and SEPT Cover Actuator power from Spacecraft	TBD-SEP-002	TBD-UNH001	TBD-UCB001
SEP-P4	IDPU to SEP Interface	HD15P	TBD-UCB-001	TBD-SEP-001
SEP-P5	SEP to SIT Interface	TBD-SEP-002	TBD-SEP-001	TBD-SEP-001
SEP-P6	SEP to SEPT-NS Bias Interface	TBD-SEP-002	TBD-SEP-001	TBD-SEP-001
SEP-P7	SEP to SEPT-NS Dig/Ana/Pwr Interface	TBD-SEP-002	TBD-SEP-001	TBD-SEP-001
SEP-P8	SEP to SEPT-E Bias Interface	TBD-SEP-002	TBD-SEP-001	TBD-SEP-001
SEP-P9	SEP to SEPT-E Dig/Ana/Pwr Interface	TBD-SEP-002	TBD-SEP-001	TBD-SEP-001
SEP-P10	SEP to HET Interface	TBD-SEP-002	TBD-SEP-001	TBD-SEP-001
SEP-P11	SEP to LET Interface	TBD-SEP-002	TBD-SEP-001	TBD-SEP-001

3.6. SEPT-E Connectors

Name	Use	Type	Part Number	Mating Connector
SEPTE-P1	SEP to SEPT-E Bias Interface	TBD-SEP-002	TBD-SEP-001	TBD-SEPT-001
SEPTE-P2	SEP to SEPT-E Dig/Ana/Pwr Interface	TBD-SEP-002	TBD-SEP-001	TBD-SEPT-001

3.7. SEPT-NS Connectors

Name	Use	Type	Part Number	Mating Connector
SEPTNS-P1	SEP to SEPT-NS Bias Interface	TBD-SEP-002	TBD-SEP-001	TBD-SEPT-001
SEPTNS-P2	SEP to SEPT-NS Dig/Ana/Pwr Interface	TBD-SEP-002	TBD-SEP-001	TBD-SEPT-001

3.8. SIT Connectors

Name	Use	Type	Part Number	Mating Connector
SIT-P1	SEP to SIT Interface	TBD-SEP-002	TBD-SEP-001	TBD-SEP-001
SIT-P2	SIT HV Disable Plug / Test Interface	TBD-SIT-002	TBD-SEP-001	TBD-SEP-001

3.9. HET Connector

Name	Use	Type	Part Number	Mating Connector
HET-P1	SEP to HET Interface	TBD-SEP-002	TBD-SEP-001	TBD-SEP-001

3.10. LET Connector

Name	Use	Type	Part Number	Mating Connector
LET-P1	SEP to LET Interface	TBD-SEP-002	TBD-SEP-001	TBD-SEP-001

4. Connector Pinouts

In the following tables:

?? TSPN is a twisted-shielded pair with shield not connected (at this end).

?? TSPS is a twisted shielded pair with shield terminated on the connector backshell.

?? TP is a twisted pair, no shield or jacket (just two wires twisted together).

?? **TSQ is a twisted shielded quad (shield terminated at backshell)**

?? Coax is an RG178 (**TBR-UCB-002**) coax

?? TA is 77 ohm twinax used for the 1553 harness, type M17/176-00002

All harnesses will have a common over-shield connected to chassis ground at both ends except where otherwise noted.

4.1. IDPU Connectors

4.1.1. IDPU-P1 (IDPU Power)

Pin	Signal	Destination	Harness
1	Spare		
2	+28V Primary	Spacecraft	#22 TSQ w/3,10,11
3	+28V Redundant	Spacecraft	#22 TSQ w/2,10,11
4	Spare		
5	+28V Heater Primary	Spacecraft	#22 TSQ w/6,13,14
6	+28V Heater Redundant	Spacecraft	#22 TSQ w/5,13,14
7	Spare		
8	Chassis (connected in IDPU to IDPU chassis)	Spacecraft	
9	Spare		
10	+28V Return Primary	Spacecraft	#22 TSQ w/2,3,11
11	+28V Return Redundant	Spacecraft	#22 TSQ w/2,3,10
12	Spare		
13	+28V Heater Return Primary	Spacecraft	#22 TSQ w/5,6,14
14	+28V Heater Return Redundant	Spacecraft	#22 TSQ w/5,6,13
15	Spare		

4.1.2. IDPU-J2 (1553 Interface to Spacecraft)

Pin	Signal	Destination	Harness
1	1553_A_P	Spacecraft	TA-blue w/6
2	Spare		
3	Spare		
4	1553_B_P	Spacecraft	TA-blue w/5
5	1553_B_N	Spacecraft	TA-white w/4
6	1553_A_N	Spacecraft	TA-white w/1
7	Spare		
8	Spare		
9	Spare		

NOTE: This harness will not have an over-shield. Twinax shields will be connected to the connector backshell.

4.1.3. IDPU-P3 (IDPU to PLASTIC)

Pin	Signal	Destination	Harness
1	CLK	TBD-UNH-002	Coax w/2
2	CLK-RET	TBD-UNH-002	Coax Shield w/1
3	Spare		
4	Spare		
5	Spare		
6	CMD	TBD-UNH-002	Coax w/7
7	CMD-RET	TBD-UNH-002	Coax Shield w/6
8	Spare		
9	Spare		
10	Spare		
11	TLM	TBD-UNH-002	Coax w/12
12	TLM-RET	TBD-UNH-002	Coax Shield w/11
13	Spare		
14	Spare		
15	Chassis (connected in IDPU to IDPU chassis)	TBD-UNH-002	Overshield & Backshell

4.1.4. IDPU-P4 (IDPU to SEP)

Pin	Signal	Destination	Harness
1	CLK	SEP-P4 pin 1	Coax w/2
2	CLK-RET	SEP-P4 pin 2	Coax Shield w/1
3	Spare		
4	Spare		
5	Spare		
6	CMD	SEP-P4 pin 6	Coax w/7
7	CMD-RET	SEP-P4 pin 7	Coax Shield w/6
8	Spare		
9	Spare		
10	Spare		
11	TLM	SEP-P4 pin 11	Coax w/12
12	TLM-RET	SEP-P4 pin 12	Coax Shield w/11
13	Spare		
14	Spare		
15	Chassis (connected in IDPU to IDPU chassis)	SEP-P4 pin 15	Overshield & Backshell

4.1.5. IDPU-P5 (IDPU to SWEA/STE)

Pin	Signal	Destination	Harness
1	CLK	BOOM-P4 pin 1	Coax w/2
2	CLK-RET	BOOM-P4 pin 2	Coax Shield w/1
3	Spare		
4	BOOM Temp.	BOOM-P4 pin 4	Coax w/5
5	BOOM Temp. RET	BOOM-P4 pin 5	Coax Shield w/4
6	CMD	BOOM-P4 pin 6	Coax w/7
7	CMD-RET	BOOM-P4 pin 7	Coax Shield w/6
8	Spare		
9	Spare		
10	Spare		
11	TLM	BOOM-P4 pin 11	Coax w/12
12	TLM-RET	BOOM-P4 pin 12	Coax Shield w/11
13	Spare		
14	Spare		
15	Chassis (connected in IDPU to IDPU chassis)	BOOM-P4 pin 15	Overshield & Backshell

4.1.6. IDPU-P6 (IDPU to MAG)

Pin	Signal	Destination	Harness
1	XYZ Drive	BOOM-P5 pin 1	Coax w/6
2	X Sensor Sig	BOOM-P5 pin 2	Coax w/7
3	Y Sensor Sig	BOOM-P5 pin 3	Coax w/8
4	Z Sensor Sig	BOOM-P5 pin 4	Coax w/9
5	MAG Temp Sensor	BOOM-P5 pin 5	Coax w/10
6	XYZ Drive RET	BOOM-P5 pin 6	Coax Shield w/1
7	X Sensor Sig RET	BOOM-P5 pin 7	Coax Shield w/2
8	Y Sensor Sig RET	BOOM-P5 pin 8	Coax Shield w/3
9	Z Sensor Sig RET	BOOM-P5 pin 9	Coax Shield w/4
10	MAG Temp Sensor RET	BOOM-P5 pin 10	Coax Shield w/5
11	MAG Heater	BOOM-P5 pin 11	#26 TSP w/12
12	MAG Heater RET	BOOM-P5 pin 12	#26 TSP w/11
13	MAG Heater Shield (*)	BOOM-P5 pin 13	#26 TSP Shield
14	Spare		
15	Chassis (connected in IDPU to IDPU chassis)	BOOM-P5 pin 15	Overshield & Backshell

(*) see 4.3.6

4.2. Boom Connectors

4.2.1. BOOM-P1 (SWEA/STE Power)

Pin	Signal	Destination	Harness
1	Spare		
2	+28V Primary	Spacecraft	#22 TSQ w/3,10,11
3	+28V Redundant	Spacecraft	#22 TSQ w/2,10,11
4	Spare		
5	+28V Heater Primary	Spacecraft	#22 TSQ w/6,13,14
6	+28V Heater Redundant	Spacecraft	#22 TSQ w/5,13,14
7	Spare		
8	Chassis (connected in BOOM to BOOM chassis)	Spacecraft	
9	Spare		
10	+28V Return Primary	Spacecraft	#22 TSQ w/2,3,11
11	+28V Return Redundant	Spacecraft	#22 TSQ w/2,3,10
12	Spare		
13	+28V Heater Return Primary	Spacecraft	#22 TSQ w/5,6,14
14	+28V Heater Return Redundant	Spacecraft	#22 TSQ w/5,6,13
15	Spare		

4.2.2. BOOM-P2 (SWEA S/C Temp Sensor)

Pin	Signal	Destination	Harness
1	SWEA Temp Sensor	Spacecraft	
2	BOOM Temp Sensor	Spacecraft	
3	Spare		
4	Spare		
5	Spare		
6	SWEA Temp Sensor RET	Spacecraft	
7	BOOM Temp Sensor RET	Spacecraft	
8	Spare		
9	Spare		

4.2.3. BOOM-P3 (Boom Actuator Power)

Pin	Signal	Destination	Harness
1	BOOM Release	Spacecraft	#22 TSPS w/6
2	Spare		
3	Spare		
4	Spare		
5	Spare		
6	BOOM Release RET	Spacecraft	#22 TSPS w/1
7	Spare	Spacecraft	#22 TSPS-Sheild
8	Spare		
9	Shield Ground (Connected to BOOM chassis inside BOOM)		

4.2.4. BOOM-P4 (SWEA/STE to IDPU)

Pin	Signal	Destination	Harness	
1	CLK	IDPU-P5 pin 1	Coax w/2	
2	CLK-RET	IDPU-P5 pin 2	Coax Shield w/1	
3	Spare	IDPU-P5 pin 4 IDPU-P5 pin 5 IDPU-P5 pin 6 IDPU-P5 pin 7	Coax w/5	
4	BOOM Temp.		Coax Shield w/4	
5	BOOM Temp. RET		Coax w/7	
6	CMD		Coax Shield w/6	
7	CMD-RET		IDPU-P5 pin 11 IDPU-P5 pin 12	Coax w/12
8	Spare			Coax Shield w/11
9	Spare			IDPU-P5 pin 15
10	Spare			
11	TLM			
12	TLM-RET			
13	Spare			
14	Spare			
15	Chassis (connected in BOOM to BOOM chassis)			

4.2.5. BOOM-P5 (IDPU to MAG)

Pin	Signal	Destination	Harness
1	XYZ Drive	IDPU-P6 pin 1	Coax w/6
2	X Sensor Sig	IDPU-P6 pin 2	Coax w/7
3	Y Sensor Sig	IDPU-P6 pin 3	Coax w/8
4	Z Sensor Sig	IDPU-P6 pin 4	Coax w/9
5	MAG Temp Sensor	IDPU-P6 pin 5	Coax w/10
6	XYZ Drive RET	IDPU-P6 pin 6	Coax Shield w/1
7	X Sensor Sig RET	IDPU-P6 pin 7	Coax Shield w/2
8	Y Sensor Sig RET	IDPU-P6 pin 8	Coax Shield w/3
9	Z Sensor Sig RET	IDPU-P6 pin 9	Coax Shield w/4
10	MAG Temp Sensor RET	IDPU-P6 pin 10	Coax Shield w/5
11	MAG Heater	IDPU-P6 pin 11	#26 TSP w/12
12	MAG Heater RET	IDPU-P6 pin 12	#26 TSP w/11
13	MAG Heater Shield (*)	IDPU-P6 pin 13	#26 TSP Shield
14	Spare		
15	Chassis (connected in BOOM to BOOM chassis)	IDPU-P6 pin 15	Overshield & Backshell

(*) see 4.3.6

4.3. *Internal Boom Harness*

4.3.1. BOOM-J1 (SWEA/STE Power)

Pin	Signal	Destination	Harness
1	Spare		
2	+28V Primary	SWEA-P1 pin 9	#26 TP w/5
3	+28V Redundant	SWEA-P1 pin 9	#26 TP w/5
4	Spare		
5	+28V Heater Primary	SWEA-P1 pin 10	#26 TP w/2
6	+28V Heater Redundant	SWEA-P1 pin 10	#26 TP w/2
7	Spare		
8	Chassis (connected in BOOM to BOOM chassis)		Overshield
9	Spare		
10	+28V Return Primary	SWEA-P1 pin 13	#26 TP w/13
11	+28V Return Redundant	SWEA-P1 pin 13	#26 TP w/13
12	Spare		
13	+28V Heater Return Primary	SWEA-P1 pin 14	#26 TP w/10
14	+28V Heater Return Redundant	SWEA-P1 pin 14	#26 TP w/10
15	Spare		

Note primary and redundant power connected at BOOM-J1, with a single TP up the boom

4.3.2. BOOM-J2 (SWEA S/C Temp Sensor)

Pin	Signal	Destination	Harness
1	SWEA Temp Sensor	SWEA-P1 pin 4	#26 TP w/6
2	BOOM Temp Sensor	Boom	
3	Spare		
4	Spare		
5	Spare		
6	SWEA Temp Sensor RET	SWEA-P1 pin 5	#26 TP w/1
7	BOOM Temp Sensor RET	Boom	
8	Spare		
9	Spare		

4.3.3. BOOM-J4 (SWEA/STE to IDPU)

Pin	Signal	Destination	Harness
1	CLK	SWEA-P1 pin 1	Coax w/2
2	CLK-RET	SWEA-P1 pin 2	Coax Shield w/1
3	Spare		
4	Boom Temp.	BOOM	
5	BOOM Temp. RET	BOOM	
6	CMD	SWEA-P1 pin 6	Coax w/7
7	CMD-RET	SWEA-P1 pin 7	Coax Shield w/6
8	Spare		
9	Spare		
10	Spare		
11	TLM	SWEA-P1 pin 11	Coax w/12
12	TLM-RET	SWEA-P1 pin 12	Coax Shield w/11
13	Spare		
14	Spare		
15	Chassis (connected in BOOM to BOOM chassis)	SWEA-P1 pin 15	Overshield & Backshell

4.3.4. BOOM-J5 (IDPU to MAG)

Pin	Signal	Destination	Harness
1	XYZ Drive	MAG-J1 pin 1	Coax w/6
2	X Sensor Sig	MAG-J1 pin 2	Coax w/7
3	Y Sensor Sig	MAG-J1 pin 3	Coax w/8
4	Z Sensor Sig	MAG-J1 pin 4	Coax w/9
5	MAG Temp Sensor	MAG-J1 pin 5	Coax w/10
6	XYZ Drive RET	MAG-J1 pin 6	Coax Shield w/1
7	X Sensor Sig RET	MAG-J1 pin 7	Coax Shield w/2
8	Y Sensor Sig RET	MAG-J1 pin 8	Coax Shield w/3
9	Z Sensor Sig RET	MAG-J1 pin 9	Coax Shield w/4
10	MAG Temp Sensor RET	MAG-J1 pin 10	Coax Shield w/5
11	MAG Heater	MAG-J1 pin 11	#26 TSP w/12
12	MAG Heater RET	MAG-J1 pin 12	#26 TSP w/11
13	MAG Heater Shield	MAG-J1 pin 13	#26 TSP Shield
14	Spare		
15	Chassis (connected in BOOM to BOOM chassis)	MAG-J1 pin 15	Overshield & Backshell

4.3.5. SWEA-P1 (IDPU to SWEA)

Pin	Signal	Destination	Harness
1	CLK	BOOM-J4 pin 1	Coax w/2
2	CLK-RET	BOOM-J4 pin 2	Coax Shield w/1
3	Spare		
4	SWEA Temp.	BOOM-J2 pin 1	#26 TP w/5
5	SWEA Temp. RET	BOOM-J2 pin 6	#26 TP w/4
6	CMD	BOOM-J4 pin 6	Coax w/7
7	CMD-RET	BOOM-J4 pin 7	Coax Shield w/6
8	Spare		
9	+28V	BOOM-J1 pin 2	#26 TP w/13
10	+28V Heater	BOOM-J1 pin 5	#26 TP w/14
11	TLM	BOOM-J4 pin 11	Coax w/12
12	TLM-RET	BOOM-J4 pin 12	Coax Shield w/11
13	+28V RET	BOOM-J1 pin 10	#26 TP w/9
14	+28V Heater RET	BOOM-J1 pin 13	#26 TP w/10
15	Chassis (connected in SWEA to SWEA chassis)	SWEA-P1 pin 15	Overshield & Backshell

4.3.6. MAG-J1 (IDPU to MAG)

Pin	Signal	Destination	Harness
1	XYZ Drive	BOOM-J5 pin 1	Coax w/6
2	X Sensor Sig	BOOM-J5 pin 2	Coax w/7
3	Y Sensor Sig	BOOM-J5 pin 3	Coax w/8
4	Z Sensor Sig	BOOM-J5 pin 4	Coax w/9
5	MAG Temp Sensor	BOOM-J5 pin 5	TP w/10
6	XYZ Drive RET	BOOM-J5 pin 6	Coax Shield w/1
7	X Sensor Sig RET	BOOM-J5 pin 7	Coax Shield w/2
8	Y Sensor Sig RET	BOOM-J5 pin 8	Coax Shield w/3
9	Z Sensor Sig RET	BOOM-J5 pin 9	Coax Shield w/4
10	MAG Temp Sensor RET	BOOM-J5 pin 10	TP w/5
11	MAG Heater	BOOM-J5 pin 11	#26 TSP w/12
12	MAG Heater RET	BOOM-J5 pin 12	#26 TSP w/11
13	MAG Heater Shield (*)	BOOM-J5 pin 13	#26 TSP Shield
14	Spare		
15	Chassis (Connect to thermal blanket ground at MAG)	BOOM-J5 pin 15	Overshield & Backshell

(*) The shielding for the MAG Temp sensor and MAG Heater are **TBR-MAG/UCB-003**. Per the EMC spec, these signals would need a secondary shield (in addition to the overshield) if they are "noisy". This will also avoid cross-talk to the other signals in the harness (SWEA and MAG). Any secondary shield should be tied to signal ground at both ends. A description of the waveform present on these signals should be used to form the basis of the shielding decision.

The wire bundle up the boom consists of the wires to MAG-J1 and SWEA-P1. This includes 7 coaxes, 4 twisted pairs, and a twisted shielded pair. A common over-shield shall be tied to chassis ground at both ends (the bottom of the boom and SWEA; MAG thermal blankets should also be connected to over-shield ground).

4.4. SWEA Connectors

4.4.1. SWEA-P1 (IDPU to SWEA)

See section 4.3.5

4.4.2. SWEA-P2 (STE)

Pin	Signal	Destination	Harness
1	OUTPUT1	STE	Coax
2	OUTPUT2	STE	Coax
3	OUTPUT3	STE	Coax
4	OUTPUT4	STE	Coax
5	OUTPUT5	STE	Coax
6	OUTPUT6	STE	Coax
7	OUTPUT7	STE	Coax
8	OUTPUT8	STE	Coax
9	STE Temp	STE	#26 TP w/18
10	OUTPUT RET	STE	Coax Shield
11	Spare		
12	Ground	STE	#26 TT w/13,14
13	+5V	STE	#26 TT w/12,14
14	-5V	STE	#26 TT w/12,13
15	Bias	STE	#26
16	-12V (TBR-UCB-004)	STE	#26
17	OUTPUT RET	STE	Coax Shield
18	STE Temp RET	STE	#26 TP w/9
19	Door Close Act.	STE	#26 TT w/20,21
20	Door Open Act.	STE	#26 TT w/19,21
21	Door Act. RET	STE	#26 TT w/19,20
22	+28V Heater	STE	#26 TP w/23
23	+28V Heater RET	STE	#26 TP w/22
24	Test RET	STE	Coax Shield w25
25	Test	STE	Coax w/24
26	Chassis (connected in SWEA to SWEA chassis)	STE	Overshield & Backshell

Note: SWEA-P2 is connected to the STE pig-tail.

4.4.3. SWEA-P3 (HV/Actuator Enable)

Pin	Signal	Destination	Harness
1	28V Supply	SWEA-P3 pin 6	
2	28V Supply	SWEA-P3 pin 7	
3	SWEA Cover Act. Supply	SWEA-P3 pin 8	
4	STE Cover Open Act. Supply	SWEA-P3 pin 9	
5	STE Cover Close Act. Supply	SWEA-P3 pin 10	
6	28V MCP HV	SWEA-P3 pin 1	
7	28V NC HV	SWEA-P3 pin 2	
8	SWEA Cover Act.	SWEA P3-pin 3	
9	STE Cover Open Act.	SWEA-P3 pin 4	
10	STE Cover Close Act.	SWEA-P3 pin 5	
11	28V Supply RET		
12	28V Supply RET		
13	Actuator RET		
14	Actuator RET		
15	Actuator RET		

Note: The RET signals are for test purposes (a dummy load/indicator can be installed between the supply and RET signals to verify operation)

4.5. SEP Connectors

4.5.1. SEP-P1 (SEP Power)

Pin	Signal	Destination	Harness
1	Spare		
2	+28V Primary	Spacecraft	#22 TP w/10
3	+28V Redundant	Spacecraft	#22 TP w/11
4	Spare		
5	+28V Heater Primary	Spacecraft	#22 TP w/13
6	+28V Heater Redundant	Spacecraft	#22 TP w/14
7	Spare		
8	Chassis (connected in SEP to SEP chassis)	Spacecraft	
9	Spare		
10	+28V Return Primary	Spacecraft	#22 TP w/2
11	+28V Return Redundant	Spacecraft	#22 TP w/3
12	Spare		
13	+28V Heater Return Primary	Spacecraft	#22 TP w/5
14	+28V Heater Return Redundant	Spacecraft	#22 TP w/6
15	Spare		

4.5.2. SEP-P2 (SEP/SEPT S/C Temp. Sensors)

Pin	Signal	Destination	Harness
1	SEP Temp Sensor	Spacecraft	
2	SEPT-NS Temp Sensor	Spacecraft	
3	Spare		
4	Spare		
5	Spare		
6	SEP Temp Sensor RET	Spacecraft	
7	SEPT-NS Temp Sensor RET	Spacecraft	
8	Spare		
9	Spare		

4.5.3. SEP-P3 (SIT & SEPT Cover Actuators)

TBD-SEP-004

4.5.4. SEP-P4 (IDPU to SEP)

Pin	Signal	Destination	Harness
1	CLK	IDPU-P4 pin 1	Coax w/2
2	CLK-RET	IDPU-P4 pin 2	Coax Shield w/1
3	Spare		
4	Spare		
5	Spare		
6	CMD	IDPU-P4 pin 6	Coax w/7
7	CMD-RET	IDPU-P4 pin 7	Coax Shield w/6
8	Spare		
9	Spare		
10	Spare		
11	TLM	IDPU-P4 pin 11	Coax w/12
12	TLM-RET	IDPU-P4 pin 12	Coax Shield w/11
13	Spare		
14	Spare		
15	Chassis (connected in SEP to SEP chassis)	IDPU-P4 pin 15	Overshield & Backshell

4.5.5. SEP-P5 (SEP to SIT)

TBD-SEP-005

4.5.6. SEP-P6 (SEP to SEPT-NS)

TBD-SEP-006

4.5.7. SEP-P7 (SEP to SEPT-NS)

TBD-SEP-007

4.5.8. SEP-P8 (SEP to SEPT-E)

TBD-SEP-008

4.5.9. SEP-P9 (SEP to SEPT-E)

TBD-SEP-009

4.5.10. SEP-P10 (SEP to HET)

TBD-SEP-010

4.5.11. SEP-P11 (SEP to LET)

TBD-SEP-011

4.6. **SEPT-E Connectors**

4.6.1. SEPT-E-P1 (SEP to SEPT-E)

TBD-SEPT-003

4.6.2. SEPT-E-P2 (SEP to SEPT-E)

TBD-SEPT-004

4.7. **SEPT-NS Connectors**

4.7.1. SEPT-NS-P1 (SEP to SEPT-NS)

TBD-SEPT-005

4.7.2. SEPT-NS-P2 (SEP to SEPT-NS)

TBD-SEPT-006

4.8. **SIT Connectors**

4.8.1. SIT-P1 (SEP to SIT)

TBD-SIT-003

4.8.2. SIT-P2 (SIT HV Disable/Test)

TBD-SIT-004

4.9. **HET Connectors**

4.9.1. HET-P1 (SEP to HET)

TBD-SEP-012

4.10. **LET Connectors**

4.10.1. LET-P1 (SEP to LET)

TBD-SEP-013

5. Harness Responsibilities

APL is responsible for the harness between the spacecraft systems and IMPACT, including the harnesses to:

- IDPU-P1
- IDPU-P2
- BOOM-P1
- BOOM-P2
- BOOM-P3
- SEP-P1
- SEP-P2
- SEP-P3

PLASTIC is responsible for the harness between PLASTIC and IDPU-P3

UCB is responsible for the following harnesses:

- IDPU-P4 to SEP-P4
- IDPU-P5 to BOOM-P4
- IDPU-P6 to BOOM-P5
- **STE-U to IDPU-P7**
- Boom Harness:
 - BOOM-J5 to MAG-J1,
 - BOOM-J1, J2, J4 to SWEA-P1
- **STE-D** to SWEA-P2
- SWEA-P3 enable plug(s)

GSFC/Acuna is responsible for the pig-tail on MAG to MAG-P1

Caltech(?) is responsible for:

- SEPTNS-P1 to SEP-P6
- **SEPTNS-P2 to SEP-P7**
- SEPTE-P1 to SEP-P8
- **SEPTE-P2 to SEP-P9**
- **SEP-P5 to SIT-P1**
- **SEP-P10 to HET-P1**
- **SEP-P11 to LET-P1**

UMd is responsible for the **SIT-P2** disable plug/test access harness